

Cavity Type AV

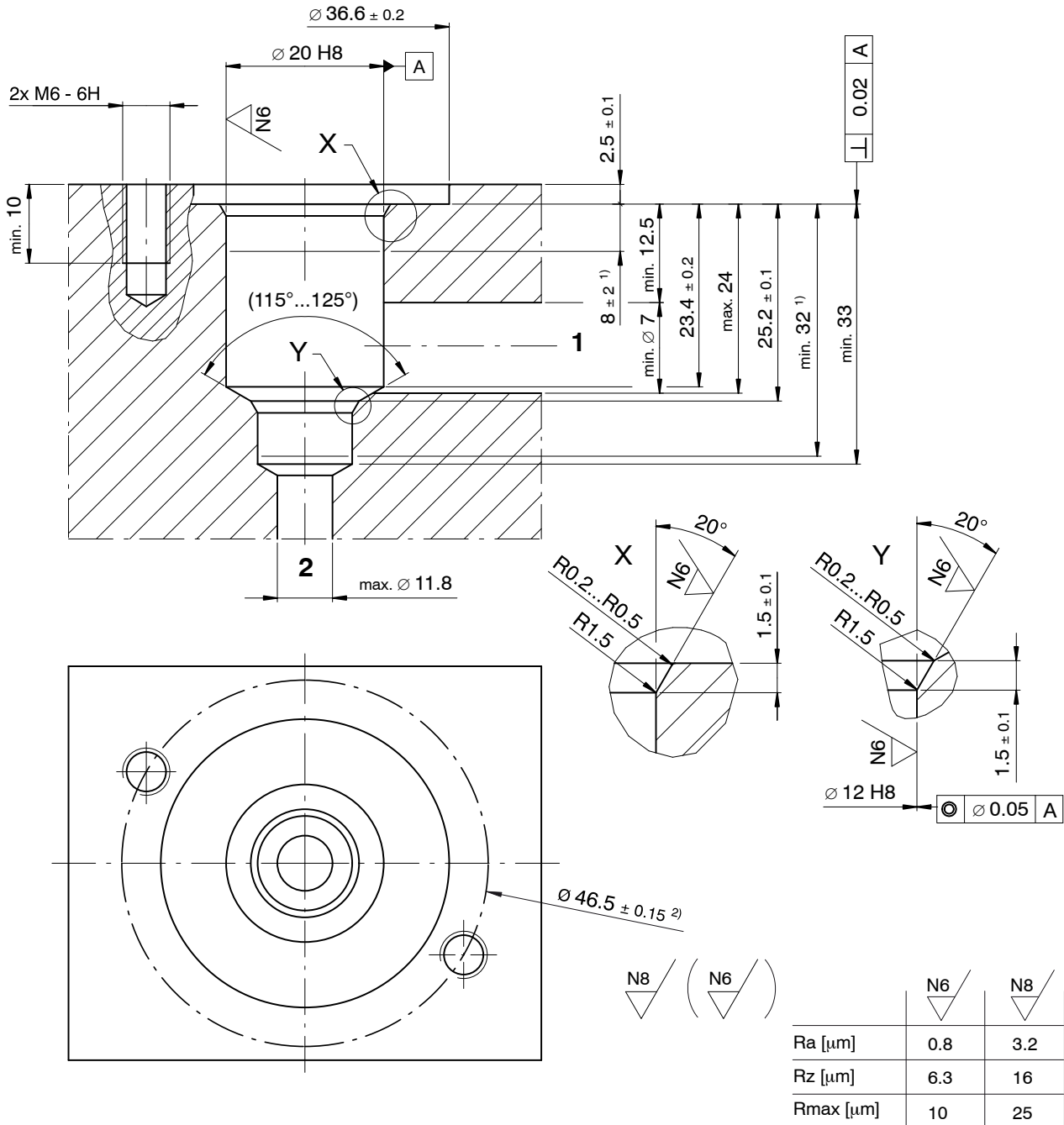

- 1) Minimum depth of specified diametral tolerance
- 2) The mounting holes can be at any desired position but must be at 180° to each other on the PCD.
Note: they must not affect the 1 drilling!

1 Machining notes



ATTENTION!

You must maintain the specified positional and diametral tolerances. To ensure trouble-free operation of the screw-in cartridges, we strongly recommend that pilot drilling, boring, reaming and cavity thread-cutting are always performed in one setup.



IMPORTANT!

We offer form tool sets for sale or hire. For further information, see data sheet 400-P-040011-EN.

2 Cartridge valves

Inverse proportional pressure-relief cartridges

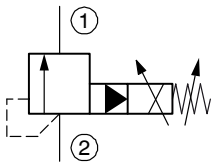

DBVCA-1G...