

# Cavity Types AY

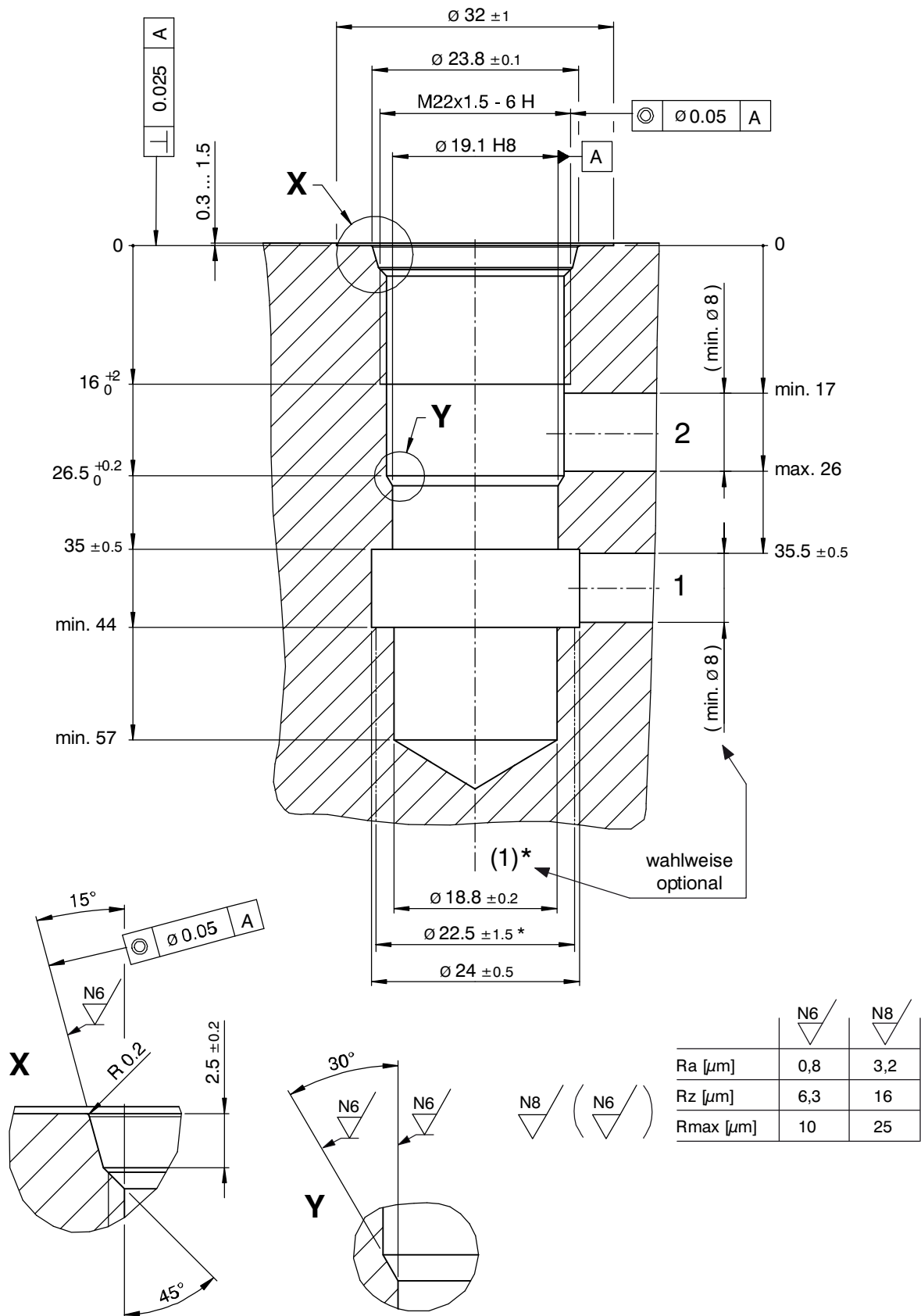

### 1 Machining notes



#### ATTENTION!

You must maintain the specified positional and diametral tolerances. To ensure trouble-free operation of the screw-in cartridges, we strongly recommend that pilot drilling, boring, reaming and cavity thread-cutting are always performed in one setup.



#### IMPORTANT!

We offer form tool sets for sale or hire. For further information, see data sheet 400-P-040011-EN.

### 2 Cartridge valves

Proportional flow-control cartridges – Series MVRPLSA-...

