

Cavity Type KTU

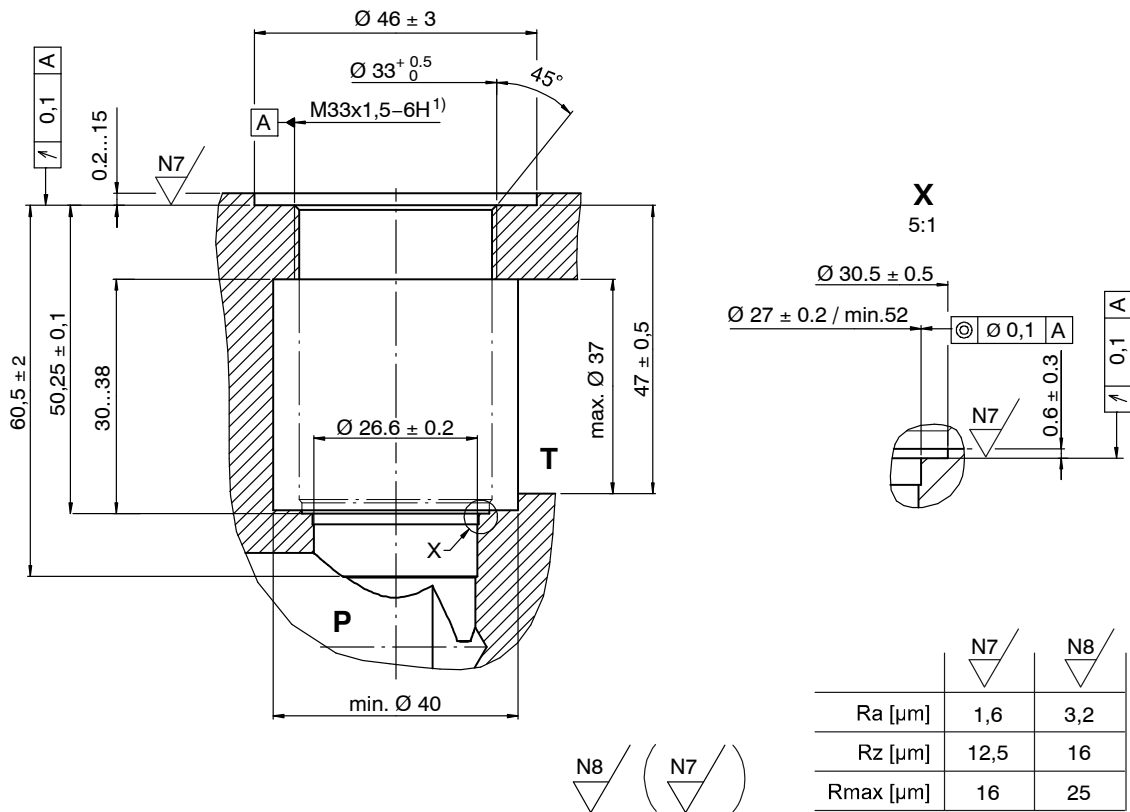

1) thread depth min. 20

1 Machining notes



ATTENTION!

You must maintain the specified positional and diametral tolerances. To ensure trouble-free operation of the screw-in cartridges, we strongly recommend that pilot drilling, boring, reaming and cavity thread-cutting are always performed in one setup.



IMPORTANT!

We offer form tool sets for sale or hire. For further information, see data sheet 400-P-040011-EN.

2 Cartridge valves

Cooler-Bypass Thermostat Valve, Series WDTUVB-16...

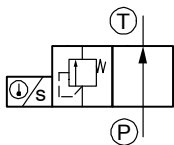

info.ch@bucherhydraulics.com

www.bucherhydraulics.com

© 2016 by Bucher Hydraulics AG Frutigen, CH-3714 Frutigen

All rights reserved.

Data is provided for the purpose of product description only, and must not be construed as warranted characteristics in the legal sense. The information does not relieve users from the duty of conducting their own evaluations and tests. Because the products are subject to continual improvement, we reserve the right to amend the product specifications contained in this catalogue.

Classification: 430.Info. ...

Reference: 400-P-080141-EN-03