

Differential Lock Valve

Series MT..DV (for 2 motors)

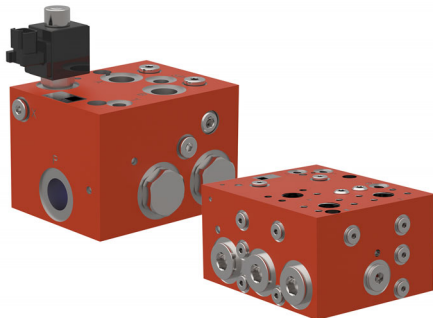

- robust and reliable
- energy-optimised over the whole flow range
- simple control
- compact design offers space-saving installation
- reliable, uniform motion of the wheel-drives being controlled

1 Description

1.1 General

The differential lock valve consists essentially of a bi-directional flow divider (dividing and combining) and a directional valve for optionally bypassing the flow divider.

It is intended for use in either open- or closed-loop hydrostatic drives with parallel-connected hydraulic motors. When the lock valve is switched OFF, the inlet flow can divide itself among the motors in any required manner. When the lock valve is switched ON, however, the inlet flow is divided into two pressure compensated portions in accordance with the division ratio of the lock valve. The motors are

thus driven at fixed speeds, regardless of their respective loads. This arrangement prevents any hydraulic wheel motor from spinning in conditions of poor traction. A balancing orifice can optionally be arranged between the outlets A and B. This allows some redistribution of flow and prevents unwanted torque build-up between wheels in these circumstances, and when turning. The differential lock valves can be supplied with either hydraulic, or electrohydraulic, actuation.

1.2 Application examples

- Harvester
- Highway finisher / pavers
- Forestry machines
- Agriculture machinery
- Ride-on mowers
- Lifting devices

2 Symbols

2.1 Hydraulic actuation

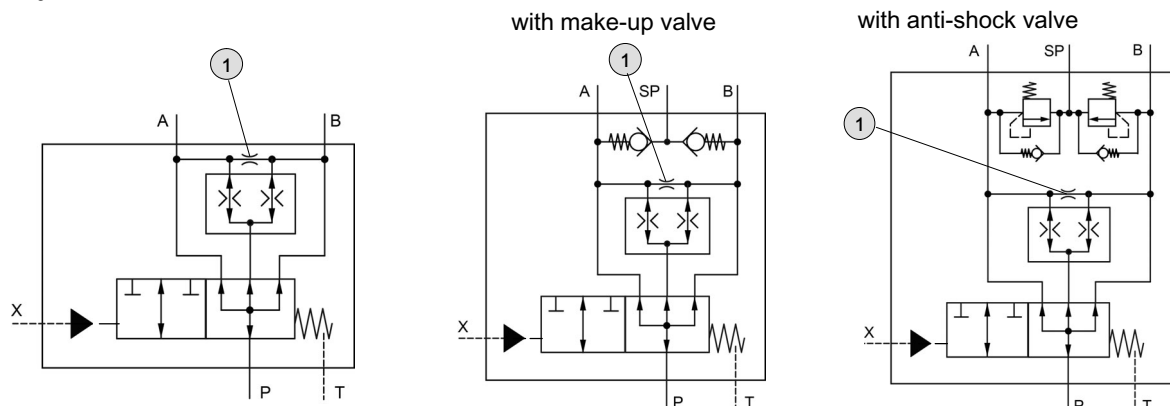

1 Balancing orifice can be fitted

Reference: 100-P-000002-US-15

2.2 Electrohydraulic actuation

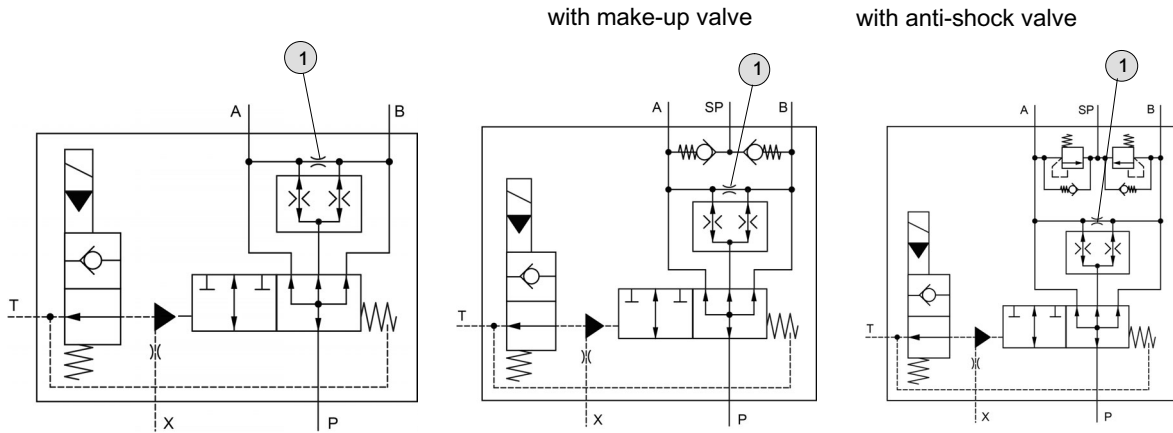

1 Balancing orifice can be fitted

3 Technical data

Hydraulic characteristics	Unit	Description, value	
		Size 08	Size 16
Nominal flow rate Q_{max} in GPM (US)	GPM	26.42 (100 l/min)	66.04 (250 l/min)
Flow range ^{1) 2)}	l/min	25 / 50 / 75 / 100	120 / 160 / 200 / 250
Flow range ^{1) 2)}	GPM	6.6 / 13.21 / 19.81 / 26.42	31.7 / 42.27 / 52.83 / 66.04
Operating pressure p_{max}	PSI	6092 (420 bar)	
Pilot pressure $p_{st min.} - p_{st max.}$	PSI	145 ... 435 (10 bar ... 30 bar)	
Viscosity range (US)	ft ² /s	1.08 ... 32.4 (10 mm ² /s...300 mm ² /s)	
Maximum fluid cleanliness		ISO 4406, class 20/18/15 achievable with a filter rating of $\beta_{10} \geq 75$	
Operating fluid temperature range	°F	-4 ... +176 (-20 °C ... +80 °C)	
Division ratio (for others, contact Bucher Hydraulics)		1:1	
Fluids		HL/HLP mineral oils DIN 51524; other fluids consult Bucher Hydraulics	
Electrical characteristics (type of actuation: EH)	Unit	Description, value	
Voltage	V DC	Direct current voltage 12 or 24	
Power consumption	W	18	
Nitrile seals		NBR	
Duty cycle		100% ED	
Ambient temperature	°F	max. +140 (+60 °C)	
Coil temperature	°F	max. +356 (+180 °C)	
Enclosure protection (when connector plugs are properly fitted)		AMP Junior Timer (2-pole) Deutsch-plug DT04-2P-EP	IP65 IP67
Electrical connection		AMP Junior Timer (2-pole) Deutsch plug DT04-2P-EP	

1) State the application's effective nominal flow when ordering.

2) Note the minimum flow per section 4.2.

4 Performance graphs

Measured with viscosity 3.78 ft²/s

4.1 Flow resistance

4.1.1 Dividing function switched OFF

In relation to the input Q_{zu} volume flow rate.

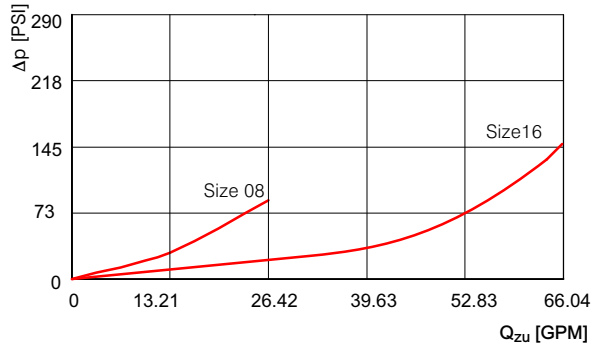

4.1.2 Dividing function switched ON

In relation to the flow range.

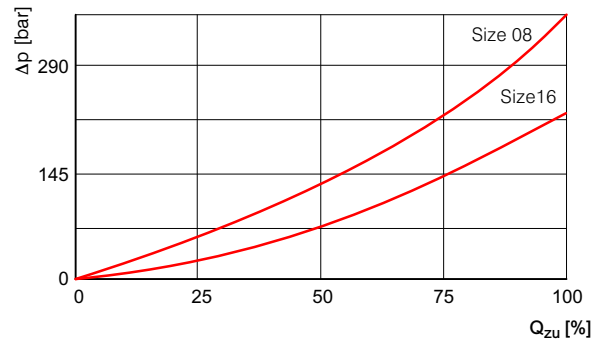

4.2 Division accuracy

Percentage of the applicable flow range without a balancing orifice between A and B (hole plugged).

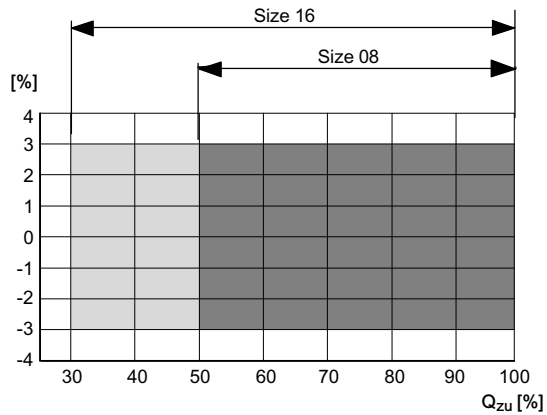

5 Dimensions in Inches

5.1 MT08DV (Serie index 3)

5.1.1 Hydraulic actuation MT08DV...-H-3***

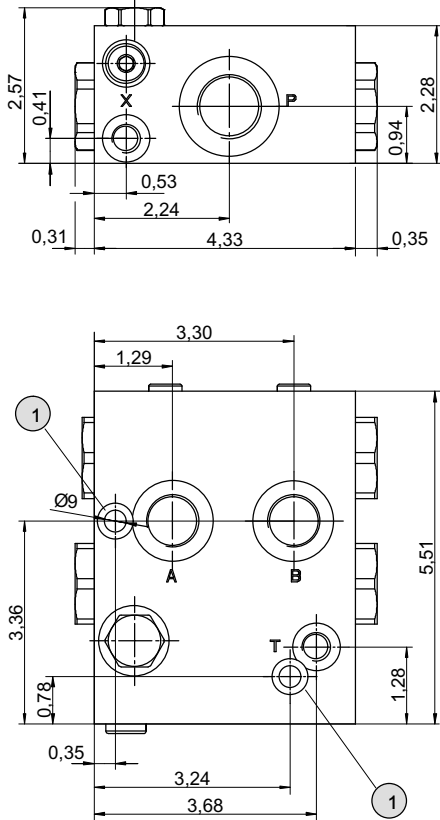

5.1.2 Electrohydraulic actuation MT08DV...-EH-3T...

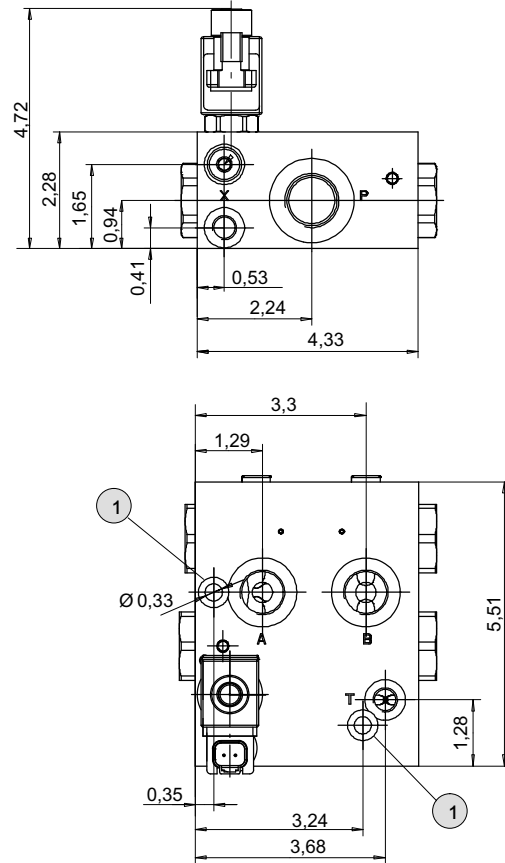

1 Clearance holes for M8 mounting cap screws to DIN 912

5.2 MT16DV (Serie index 2)

5.2.1 Hydraulic actuation MT16DV...-H-2***

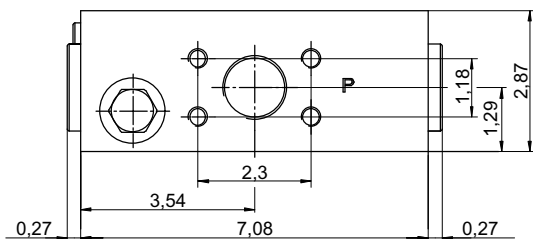

5.2.2 Electrohydraulic actuation MT16DV...-EH-2T...

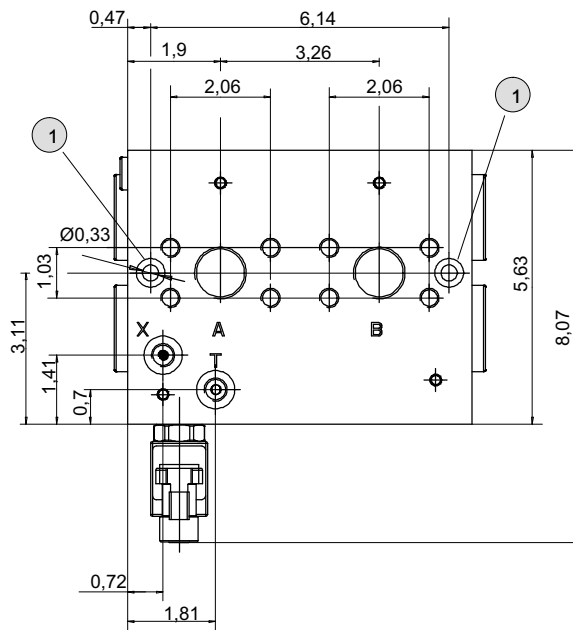
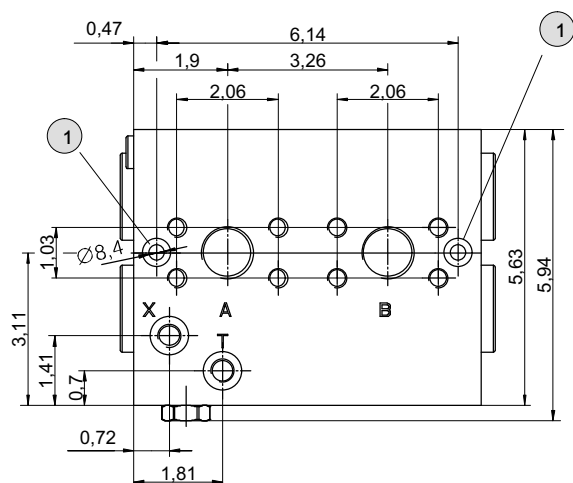
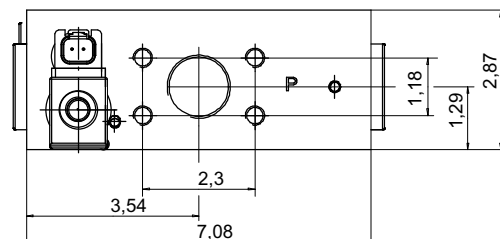

1 Clearance holes for M8 mounting cap screws to DIN 912

5.3 Connection size

MT08DV		MT16DV	
Port	Port threads	Port	Port threads
P	M27 x 2	P	M33 x 2 and SAE 1¼" (3000 PSI) ¹⁾
A, B, C	M22 x 1.5	A, B	M27 x 2 and SAE 1" (3000 PSI) ¹⁾
T, X	M12 x 1.5	T, X	M12 x 1.5

1) SAE-flange see datasheet 100-P-000049.

6 Models

6.1 Sockets

AMP Junior Timer J	Deutsch plug DT04-2P-EP04 T

7 Ordering code

	M T , 0 8 , D V	1 0	0 2 5	- E H -	. T	1 2	/ * *	D ... 2)
Differential lock valve Nom. size	= MT..DV = 08 or 16							
Division:								
1 : 1	= 10							
1:1,5 etc.)	= 15 1)							
Control flow range: per. sect. 3.	e. g. 25 l/min	= 025						
Type of actuation :	hydraulic	= *H						
	electro-hydraulic	= EH						
Design no.								
Plug connector:	AMP Junior Timre	= J						
	Deutsch plug DT04-2P-EP04	= T						
Coil voltage:	DC 12Volt	= 12						
	DC 24Volt	= 24						
	with actuation type *H	= ***						
Options (see chapter 7.1):								
	with make-up valve	= 01						
	with anti-shock valve and make up valve	= 02						
	with make-up valve and inch-size port threads	= 07						

1) With unequal division, the larger flow goes to port B.

2) Size of balancing orifices must be plainly stated (see also sect. 2) e.g. 0.6 / 0.8 / 1.0 etc. e.g.: if balancing orifice D is to be 0.8 mm, then D = 08

7.1 Options

In addition to the standard versions, differential-lock valves can also be equipped with numerous auxiliary functions and combined in customer-specific manifold blocks. In these cases, technical datas and performance graphs may differ from standard.

- /01 = with make-up valves:
- /02 = with anti-shock valves
(pressure-relief+make-up valves)
- /07 = with make-up valves and inch-size port threads

8 Application example

8.1 2-wheel drive

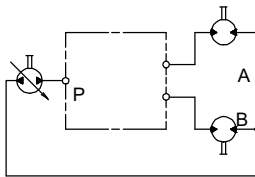

8.2 4-wheel drive

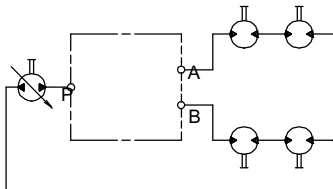

9 Installation

Horizontal mounting is recommended. Do not bolt the valve body onto an uneven mounting surface.

10 Fluid

Differential lock valves require fluid with a minimum cleanliness level of ISO 4406 code 20/18/15.

We recommend the use of fluids that contain anti-wear additives for mixed-friction operating conditions. Fluids without appropriate additives can reduce the service life of pumps and motors.

The user is responsible for maintaining, and regularly checking the fluid quality.

11 System augmentation

11.1 Switch valve for traction drives

11.1.1 USV08 und USV16 series

These valves enable switching from a serial connection, for example "drive mode," into a parallel connection using a differential lock valve. For the user, such solutions mean reliable output and fast operating speeds.



11.1.2 Application examples

- Sweepers
- Black-top pavers
- Cold milling machines
- Trench rollers
- Farm sprayers

11.1.3 Circuit diagram

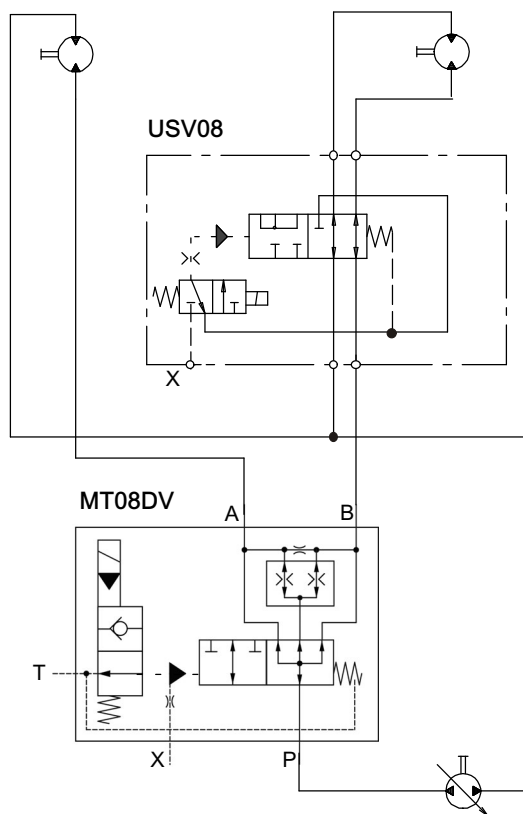

USV16

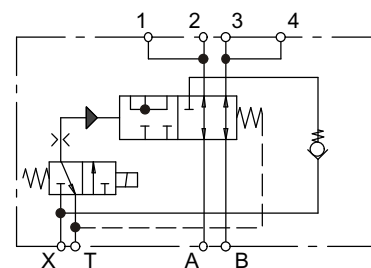

USV08

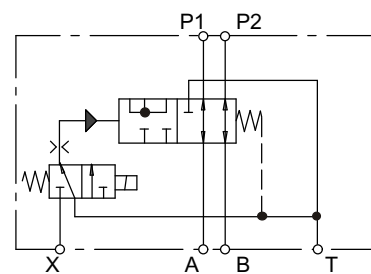

11.1.4 Technical data

Hydraulic characteristics	Unit	Description, value	
		Size 08	Size 16
Operating pressure p_{max}	PSI	6092 (420 bar)	6092 (420 bar)
Nominal flow rate	GPM	31.7 (120 l/min)	42.27 (160 l/min)
Dimensions in Inches (valve body without solenoid)	inch	6.29 x 4.13 x 5.11	8.66 x 4.64 x 7.28
Ordering information and order number		USV08-1T12 = 100040651	USV16-0T12 = 100040296
Fluid temperature range	°F	-4 ... +176 (-20 °C ... +80 °C)	
Viscosity range	ft ² /s	1.08 ... 32.4 (10 mm ² /s ... 300 mm ² /s)	
Maximum fluid cleanliness		ISO 4406, class 20/18/15 achievable with a filter rating of $\beta_{10} \geq 75$	
Nitrile seals		NBR (Nitril-Butadien-Kautschuk)	
Port threads: USV08		P1, P2, A, B = M27x2 T, C = M18x1.5 X = M14x1.5 according to DIN EN ISO 9974-1	
USV16		1 - 4, A, B = M27x2 T = M14x1.5 X = M14x1.5 according to DIN EN ISO 9974-1	
Electrical characteristics	Unit	Description, Value	
Supply voltage	V DC	12 or 24	
Supply voltage tolerance		± 10%	
Nominal power consumption	W	27	
Relative duty cycle		100%	
Enclosure protection (when connector plugs are properly fitted)		AMP Junior Timer (2-pole) Deutsch plug DT04-2P-EP	IP65 IP67
Electrical connection		AMP Junior Timer (2-pole) Deutsch plug DT04-2P-EP	