

Product article

# Safely and Reliably Control a Large Flow, and Use It with Precision

“With the size 40 load-control cartridge valve, featuring flow rates up to 1200 l/min and operating pressures up to 350 bar, Bucher Hydraulics takes its proven CINDY technology into a new performance range. Established in the market for decades, the CINDY product range means very low leakage, finger-tip controllability and load-independent cylinder travel behavior.”

In launching the CINDY load-control cartridge valve in a new size 40, Bucher Hydraulics introduces an innovative extension of the CINDY modular system to the market. The proven and well positioned CINDY technology is now available for flow rates from 20 to 1200 l/min. The compelling features of this high-performance load-control cartridge valve are its low pressure drop at high flow rates, its leak-tightness and its excellent functional stability in systems that are susceptible to oscillation. These are today's decisive criteria for the controlled and delicate movement of heavy loads.

Load-control valves in the CINDY series have, among other functions, the job of preventing hydraulic actuators from running ahead of the incoming oil flow in an uncontrolled manner. Load-holding, safety and pipe-rupture functions are also incorporated in these valves. What's more, these leak-free load-control valves are ideally suited for use at pressures up to 350 bar, where they have a safety factor of at least 3. With various optional functions, the whole CINDY modular system can be extended and adapted to the specified system requirements.

Typical applications for these premium-grade valves are mobile-, harbor- and ship-cranes, fire-fighting turntable ladders, drilling rigs, underground and tunnel boring machines, aerial work platforms, and hydraulic presses.

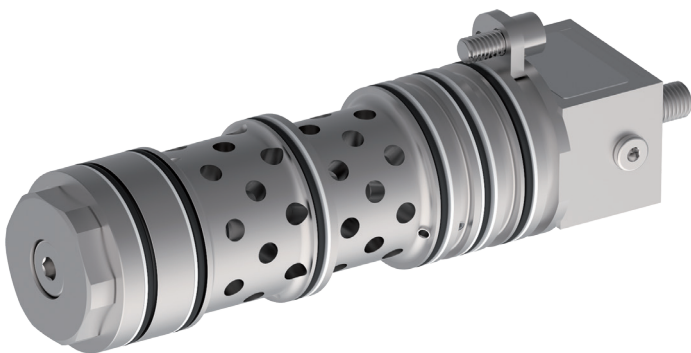

## Symbols

Variant A  
(influenced by return-line pressure)

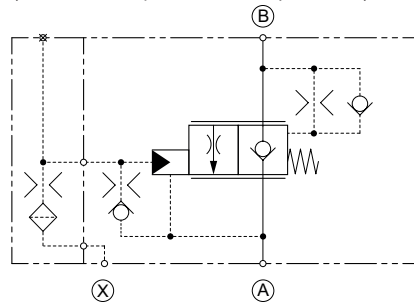

Variant L  
(not influenced by return-line pressure)

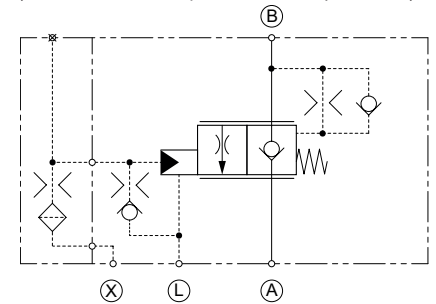

For further control types see data sheet CINDY-40-C, 300-P-9050099 on our website.

## Technical data

Design	Seat valve, cartridge-type
Maximum flow rate	1200 l/min
Maximum working pressure	350 bar
Type of operation	Hydraulic proportional
Opening pilot ratios	1:113
Surface treatment	All exposed parts are zinc-nickel plated

## Functions

### Inoperative position:

The load pressure and the compression spring act on the control spool in the closing direction. The load-control valve is closed with virtually no leakage.

### Lifting: (flow direction A > B)

The pump pressure at port A opens the load-control valve against the 'light' compression spring and the load. The pilot spool and control spool move together in the opening direction.

Oil flows from A > B and the load-control valve then functions as a check valve.

### Lowering: (flow direction B > A)

The pilot pressure at port X acts on the pilot piston and against the control springs. The pilot spool opens. As a result, the load pressure at port B is discharged to port A via the metering grooves in the pilot spool. The progressive characteristic of the decompression phase ensures that the lowering motion begins smoothly and without jerks. If the pilot pressure at port X is increased, the pilot spool opens further. The change in the pressure conditions at the control spool means that it follows the pilot spool in the opening direction. The oil flows from B > A.

**Features**

- High opening pilot ratio (113:1)
- Guaranteed closing force on the control assembly – in the case of a broken spring, for example
- Standard pilot pressures from 6 ... 20 bar (other pressures on application)
- Several damping variants can be selected

**Advantages:**

- Minimum pilot-pressure differential with different loads
- Closing function is very reliable
- Lowering takes place with minimum energy expenditure
- Can be configured for various pressure conditions with different orifice combinations

**Benefits (OEM)**

- Improved energy efficiency thanks to reduced pilot pressure
- No additional safety valve is needed
- Possibility of using smaller actuators
- No additional units needed for matching with actuators

**Benefits (end user)**

- Load-independent cylinder travel for the machine operator
- Increased safety for people and equipment, even when equipment malfunctions
- Cost savings thanks to improved energy efficiency
- Finger-tip operation thanks to a fine-control range

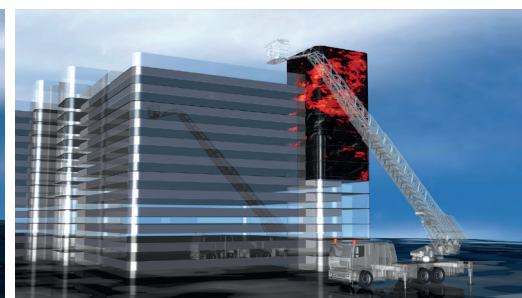
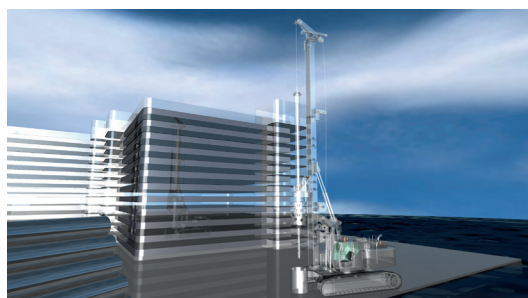

**Potential applications**

**Cylinder application**

CINDY 40-B-C with control variant type "G"

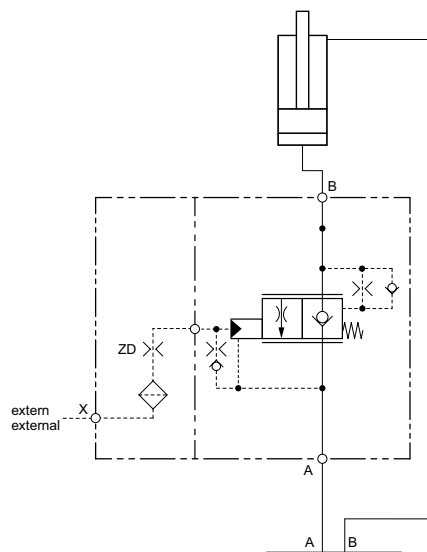

**Winch application**

CINDY 40-B-C with control variant type "K"

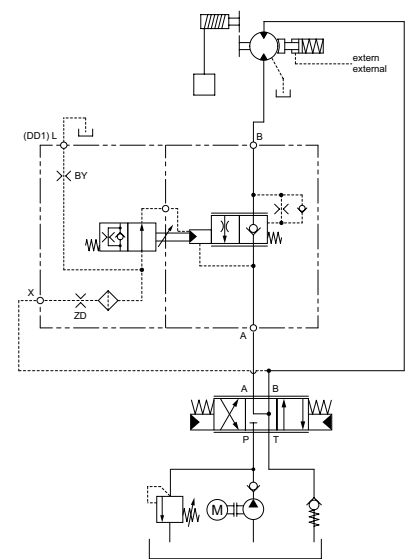

**Contact for reader enquiries:**

Bucher Hydraulics AG  
Industriestrasse 15  
CH-6345 Neuheim  
info.ch @bucherhydraulics.com  
www.bucherhydraulics.com

**Contact for editors:**

Lorenz Kallen  
Technical editor  
Tel.: +41 33 672 61 73  
E-Mail: lorenz.kallen@bucherhydraulics.com

Smart Solutions.  
Superior Support.