

APM/APMR250HP Cast Iron Gear Motors

Unidirectional and Reversible

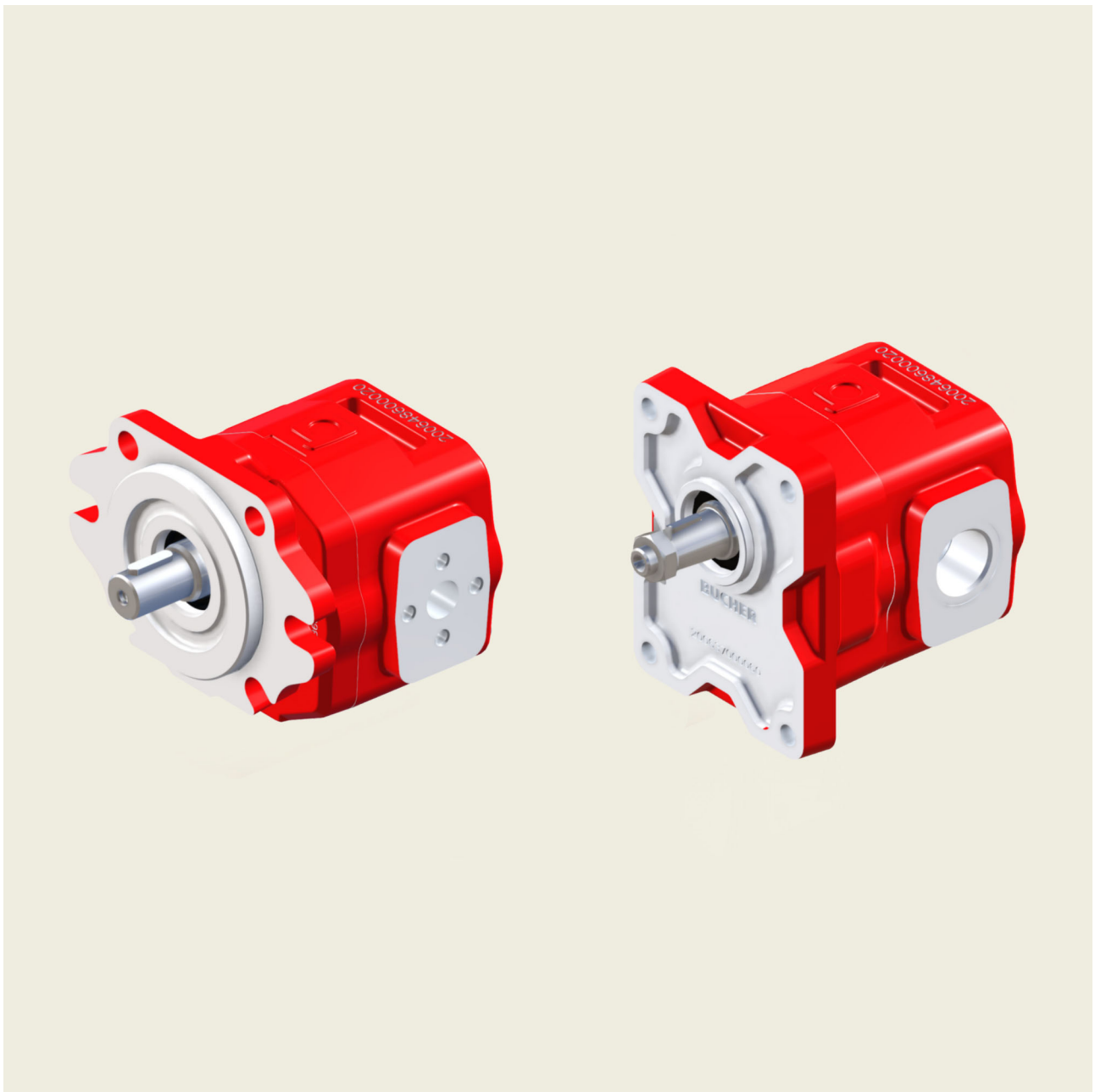

Contents

Page

1	General information	3
1.1	External gear motors components and construction / benefits	4
1.2	Technical data	5
1.3	Identifying the rotation direction	7
1.4	Outlet	7
1.5	General installation precaution	8
1.6	Directives and standards	8
1.7	Gear motor formulas	9

2	Overview standard motor configurations	10
2.1	Standard components configuration	10

3	APM250HP Customised versions	17
3.1	Single motor customised versions order example	18
3.2	Shaft end code	19
3.3	Front cover/mounting flange	20

4	Product identification plate	26
---	------------------------------------	----

5	Application form	27
---	------------------------	----

1 General information

The product range of Bucher Hydraulics SpA includes single motors APM212 - APM212HP - APM250HP (corresponding with the common group denominations: 2-2.5) .

Bucher Hydraulics SpA has supplied a wide range of external gear motors to industrial and mobile applications since many years.

Bucher's external gear motors are widely used in modern hydraulic system to obtain high performances, long life service, low purchase and maintenance costs.

Now, Bucher is introducing a new Gear motors family, APM250HP / APMR250HP (group 2.5), developed for hedge and brush cutters, stump grinders, wood chippers, grape and combine harvester applications.

Bucher designed this new motor APMR250HP with sleeve bearings mounted in the cast iron body and covers.

APM250HP/APMR250HP is the result of a focused design, studied also with the aid of a software internally developed and used for the calculations of the most important mechanical parameters of the gears and to optimize all the performances with a consequent noise and vibration reduction. Bucher Hydraulics has so achieved this state of the art by constantly improving its design, control and manufacturing techniques aligned with the latest technological developments, while simultaneously enhancing its Quality System ensuring that every single product offers the same high standards.

Main applications and benefits

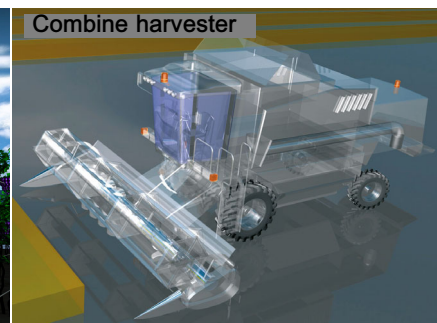
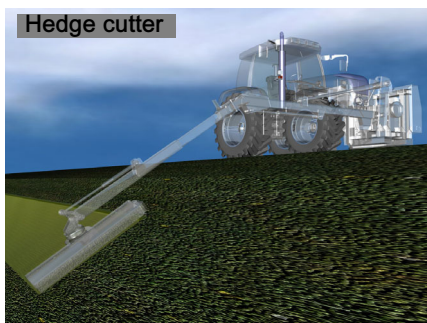

- Long life expectancy
- High efficiencies
- Noise & vibration reduction
- Strong interface
- Shaft load reduction
- High pressure limits
- Reduced number of components
- Reduced overall dimension

1.1 External gear motors components and construction / benefits

A
Cast iron front cover: two different flanges are available (SAE-B, EU).

B
Cast iron main motor body: wide range of displacements obtainable with two different raw cast with back cover integrated in only one piece. Rear ports on request.

C
HNBR seal material instead of NBR.

D
Viton and HNBR shaft seals.

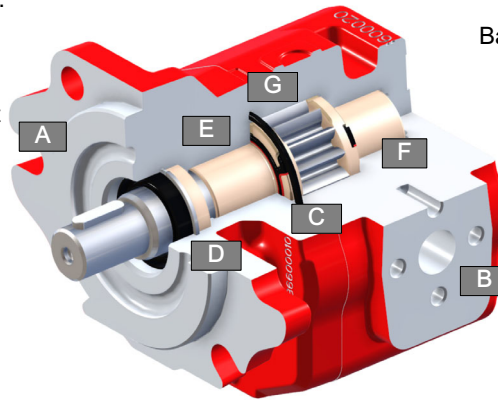

E
Pressure-balance plate manufactured in bimetallic steel-bronze. Balancing area and intermediate notches optimised.

F
Large-diameter sleeve bearings, fitted both in front cover and body.

G
Large number of teeth, tooth profile optimised, larger shaft diameter.

BENEFITS



A B Flexibility/smaller number of components

A B D Reduced risk of external leakage

A B E High efficiencies/pressure limits

A B E Long life expectancy

C D Wider temperature range

E G Lower pressure ripple

E G Noise/vibration reduction

E F G Higher load capacity and transmissible torque

E F G Low friction and high mechanical efficiency starting torque

E F G Higher max. pressure limit

The front mounting flange and the body/back cover are made of high-strength cast iron to give thermal stability, resistance to contamination and the strength necessary for persistently high levels of performance and life, needed in demanding heavy duty applications.

Body/back cover integrated, bigger shafts diameter, bigger sleeve bearing dimension and bimetallic trust plate have

been optimized to provide heavy duty, high pressure limits, high efficiencies and long life expectancy.

Noise and vibration reduction due to the high number of teeth.

The sleeve bearings are located in the front mounting flange and in the body/back cover.

1.2 Technical data

Features		
Displacements	15.2 - 54 cm ³ /rev	
Maximum continuous pressure	300 bar (depending on displacement and type)	
Fluid temperature range	-15 / +90 °C (Extreme condition temperature range: -20 +110 °C)*	
Recommended fluids	hydraulic mineral oil-based	
Viscosity range:	Recommended	20-120 mm ² /s (cSt)
	Permitted (not continuous)	up to 700 mm ² /s (cSt)
	Permitted for starting	2000 mm ² /s (cSt)
Contamination class:		
	working pressure > 210 bar	19/17/14 ISO 4406
	working pressure < 210 bar	20/18/15 ISO 4406
Standard seals material	Viton and HNBR standard	

* Extreme working limits values can not be combined

Type APM (Unidirectional)	Displacement		Pressure				Min speed rpm	Max speed rpm
			P1 (continuous)		P3 (peak)			
	cm ³ /rev	Cu.In.P.R.	bar	P.S.I.	bar	P.S.I.		
15	15.2	.928	300	4300	320	4600	500	3500
19	19.1	1.166	300	4300	320	4600	500	3500
23	23	1.403	300	4300	320	4600	500	3500
26	26.4	1.611	300	4300	320	4600	500	3500
29	29.3	1.788	300	4300	320	4600	500	3500
33	33.2	2.026	300	4300	320	4600	500	3500
36	36.1	2.203	300	4300	320	4600	500	3500
40	40.5	2.471	275	4000	290	4200	500	3500
45	45.3	2.764	245	3500	260	3700	500	3500
50	50.2	3.063	220	3200	235	3400	500	3000
54	54	3.295	205	3000	220	3200	500	3000



IMPORTANT!: The pressure values are referred to unidirectional motors. Please consult Bucher Hydraulics if even one of the operating limits indicated in the table (temperature, pressure, rpm) is exceeded, as well as in the case of two or more maximum values at the same time, or for applications with particularly heavy-duty cycles

Type APMR (Bidirectional, Unidirectional + external drain)	Displacement		Pressure				Min speed rpm	Max speed rpm
			P1 (continuous)		P3 (peak)			
	cm ³ /rev	Cu.In.P.R.	bar	P.S.I.	bar	P.S.I.		
15	15.2	.928	270	3900	300	4350	500	3500
19	19.1	1.166	270	3900	300	4350	500	3500
23	23	1.403	270	3900	300	4350	500	3500
26	26.4	1.611	250	3600	270	3900	500	3500
29	29.3	1.788	250	3600	270	3900	500	3500
33	33.2	2.026	250	3600	270	3900	500	3500
36	36.1	2.203	250	3600	270	3900	500	3500
40	40.5	2.471	240	3480	260	3770	500	3500
45	45.3	2.764	210	3050	230	3300	500	3500
50	50.2	3.063	190	2750	210	3050	500	3000
54	54	3.295	180	2610	200	2900	500	3000



IMPORTANT!: The pressure values are referred to bidirectional motors. Please consult Bucher Hydraulics if even one of the operating limits indicated in the table (temperature, pressure, rpm) is exceeded, as well as in the case of two or more maximum values at the same time, or for applications with particularly heavy-duty cycles

Limit indications:

Shaft seal: Maximum pressure admitted

IMPORTANT! The pressure on the outlet line has to be checked in order to choose the right motor configuration. Different solutions are available depending on pressure value recorded. See examples from 1 to 4

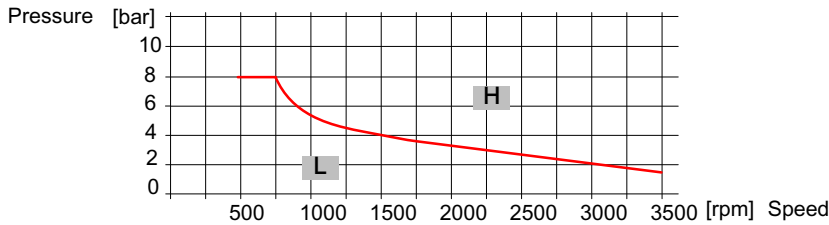

These limits have to be respected in the worst working conditions

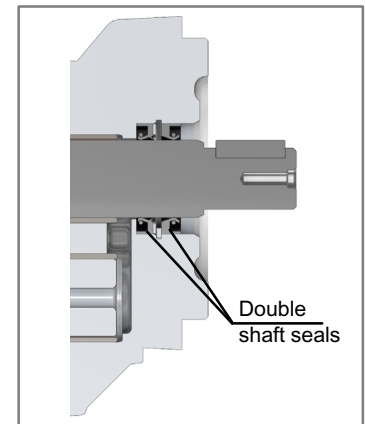

1 Unidirectional motor APM

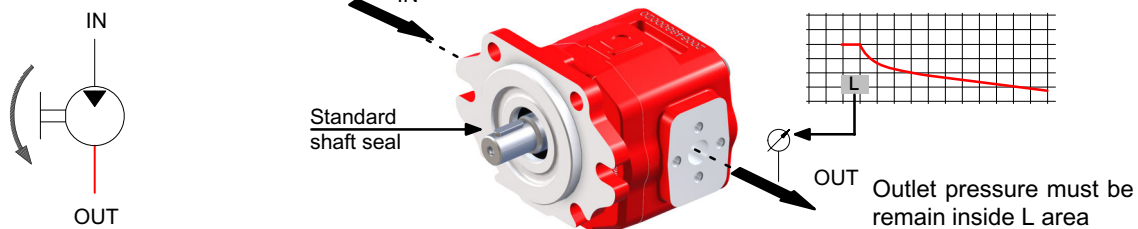

2 Unidirectional motor APMR with external drain

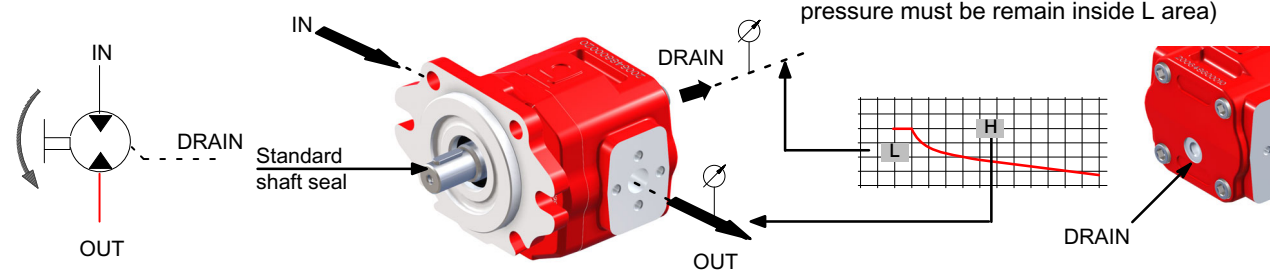

3 Bidirectional motor APMR with external drain (SAE-B)

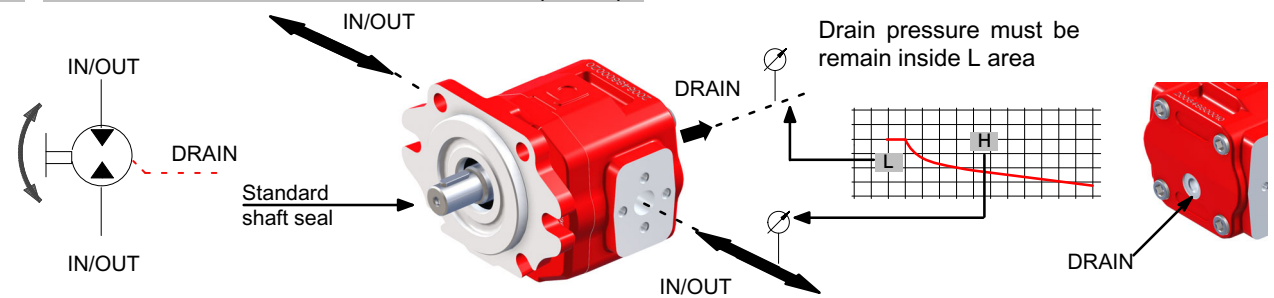

4 Bidirectional motor APMR with external drain (EU)

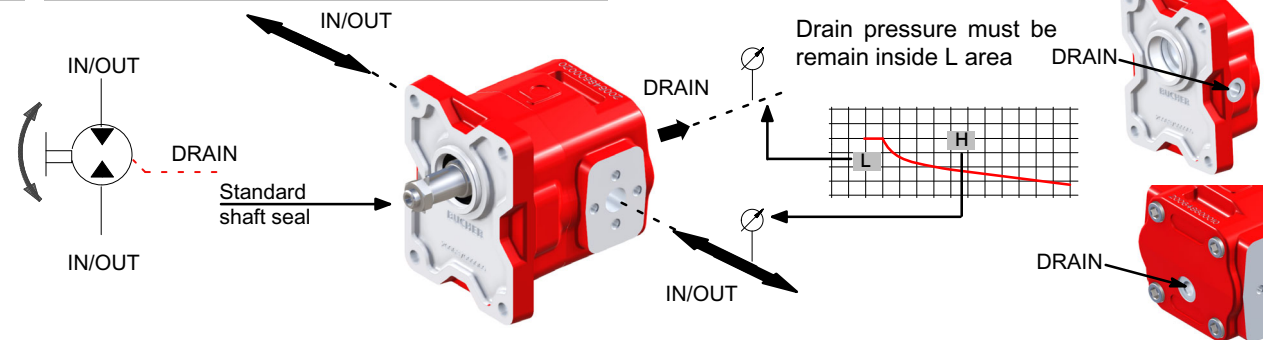

1.3 Identifying the rotation direction

The rotation direction of a gear motor is identified by looking at the motor from the front and with the drive gear turned upwards (see figures below).

Motors with clockwise rotation (D) have a drive gear which turns clockwise, with the inlet port on the left and the outlet port on the right.

Motors with counterclockwise rotation (S) have a drive gear which turns counterclockwise, with the inlet port on the right and the outlet port on the left.

The figure also shows the pressure flow inside the motors as the oil is transferred from the inlet port to the outlet port.

As regards reversible motors (R), the ports are alternatively for inlet and outlet.

Motors with a unidirectional rotation (D or S) have the denomination APM. Motors with reversible rotation have the denomination APMR.

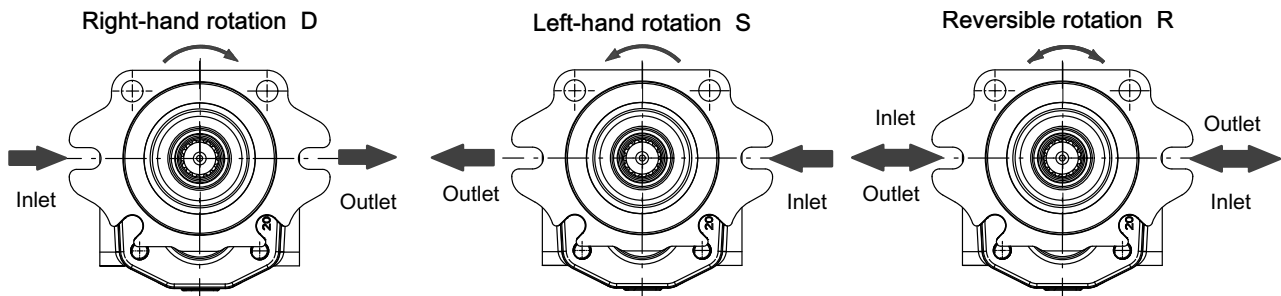

1.4 Outlet

1.4.1 Unidirectional motors

As a matter of principle, unidirectional motors correspond to counter rotating motors.

The balancing seals are not symmetric and, consequently, two different pressure sides: inlet High-pressure and outlet Low-pressure side, which must not be exchanged each other, are defined.

The maximum outlet Low-pressure value is limited by the shaft seal and its support, see limit indications, page 6

To keep P out below the suggested value, the following must be avoided:

- long distance between motor and tank
- long stretches of piping
- special features such as: bends; reductions in diameter;

quick couplings; etc.

Having filtration on the return it is also advisable to choose a filter of a suitable size to minimise any pressure drop and to take measures to prevent gradual clogging over time.

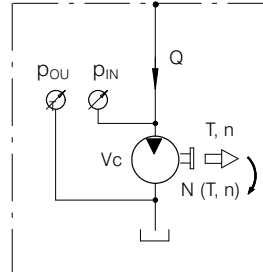

1.4.2 Reversible motors

Reversible rotating motors have symmetric balancing seals and both ports, inlet and outlet, can be, alternatively, operate as inlet High-pressure and outlet Low-pressure.

Sealed area is connected to the back side of the oil retaining shaft seal and its pressure must be limited connecting it to the tank, through a drain threaded port placed on the motor rear cover with SAE-B flange, and it also can be machined on lateral side with European flange. The drain hose must be chosen in order to avoid that the pressure at the drain port does not exceed the maximum admitted pressure, see limit indications, page 6.

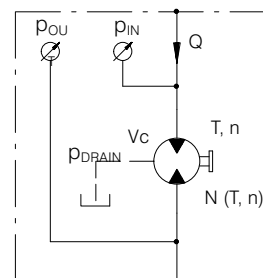

1.5 General installation precaution

In addition to the recommendations regarding fluids, filtration, coupling, etc., Bucher Hydraulics suggest the following indications:

- For unidirectional motors check always the rotation direction of the motor's take off shaft; it must be compatible with the rotation direction of the motor itself.
- Be particularly careful in cleaning and make sure, when connecting the high and low pressure piping, that no chips, rag threads, teflon tape, etc. get into the motor circulation system.
- Check the tightness of the high and low pressure fittings,

the correct positioning of the O-Ring, and make sure there is no dirt between the flange and the motor body. The pipes themselves should be below oil tank level to prevent the formation of foam.

- Do not subject the motors to operating conditions different from those indicated on section 1.2 ; for extreme operations, always contact our Technical Department.
- Ambient temperature range: -20 / +50 °C
- In the event of motor painting, do not use solvents or paints that are incompatible with the material of the seals. Do not bake paint with excessively high temperatures.

Example of several hydraulic circuits are available on demand (please consult Bucher Hydraulics).

1.5.1 Hydraulic fluid

The main function of the fluid used in hydraulic systems is to transfer energy but it performs also other important functions: protect the components from corrosion, lubricate the motor moving parts, remove particles and heat from the system.

In order to ensure proper operation and long life of the system it is important to choose the correct hydraulic fluid with proper additives.

Bucher Hydraulics recommends to use a mineral based oil responding to ISO 6743/4 requirements, only.

The system should be operated only with hydraulic oil containing anti-foaming and antioxidant additives. Before using other types of fluid, please contact our Sales Dept, since they can cause serious damage to the directional valve components and jeopardize the correct function of the system.

Never use fluids different from those indicated in section 1.2 and do not use fluids incompatible with the motor seals (i.e. HNBR)

1.5.2 Filtration

In order to ensure proper operation and long life of the motor components it is extremely important to provide a proper and effective filtration of the hydraulic fluid.

It is advisable to follow filter manufacturers instruction and recommendations.

The fineness of the filter should be selected in order to guarantee that a contamination levels indicated on section 1.2. When the high reliability of the system is an important requirement, a pressure filter must be used. In these cases it is also advisable to use a pressure filter with by-pass and indicator.

The size of the return filters must suit the maximum return

flow whereas the size of the pressure filters must suit the maximum motor flow.

It is advisable to fit filters with pressure gauge or dirt indicator in order to make it possible to verify the filter condition. Particular attention has to be paid to the cleaning of the machine hydraulic circuit and its components before the first run-in, since the presence of foreign materials could cause damages even if a proper filtration is provided.

In order to obtain the best performance of the system we recommend to strictly follow the conditions advised here above, failing which warranty shall be void.

1.6 Directives and standards

- Atex:



Attention: The equipment and protective systems of this catalogue ARE NOT intended for use in potentially explosive atmospheres. Ref: Directive 99/92/EC and Directive 2014/34/UE

- ISO 9001:2015 / ISO 14001:2015

Bucher Hydraulics S.p.A. is certified for research, development and production of directional control valves, power units, gear motors and motors, electro motors, cartridge valves and integrated manifolds for hydraulic applications.

1.7 Gear motor formulas

The following parameters are defined:

V_c = (cm³/r) motor displacement;

n = (r/min) no. of rpm of the outlet shaft;

Q = (l/min) flow rate;

Δp = (bar) P_{IN}-P_{OUT}, operating Δp pressure;

T = (Nm) outlet torque;

N = (kW) outlet power;

η_v = (%) volumetric efficiency;

η_m = (%) mechanical efficiency;

η_t = (%) total efficiency (η_t = η_v · η_m)

1.7.1 Parameter relationships

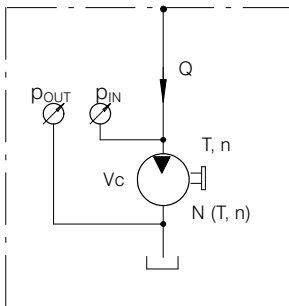
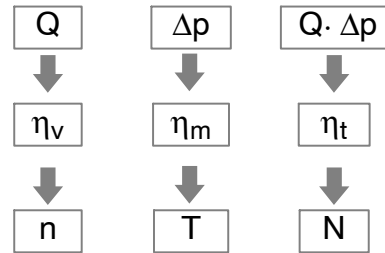

$$Q = \frac{V_c \cdot n}{10 \cdot \eta_v}$$

$$V_c = \frac{10 \cdot Q}{n} \cdot \eta_v$$

$$n = \frac{10 \cdot Q}{V_c} \cdot \eta_v$$

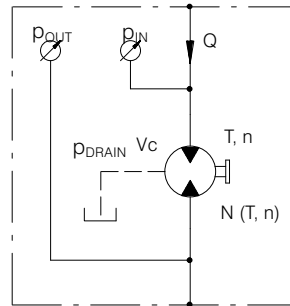

$$\Delta p = \frac{T}{1.592 \cdot V_c \cdot \eta_m} \cdot 10^4$$

$$V_c = \frac{T}{1.592 \cdot \Delta p \cdot \eta_m} \cdot 10^4$$

$$T = 1.592 \cdot V_c \cdot \Delta p \cdot \eta_m \cdot 10^{-4} \quad N = \frac{Q \cdot \Delta p}{6 \cdot 10^4} \cdot \eta_t$$

Example

APM250HP/15 V_c = 15 cm³/r Q_{IN} = 30 l/min Δp = 230 bar η_v = 90% η_m = 90%

$$n = \frac{10 \cdot 30}{15} \cdot 90 = 1800 \text{ r/min.}$$

$$\eta_t = 0.90 \cdot 0.90 = 0.81 = 81\%$$

$$N = \frac{30 \cdot 230 \cdot 81}{6 \cdot 10^4} = 9.32 \text{ kW}$$

$$T = 1.592 \cdot 15 \cdot 230 \cdot 90 \cdot 10^{-4} = 49.43 \text{ Nm}$$

2 Overview standard motor configurations

This motor configuration example is considered as "standard":

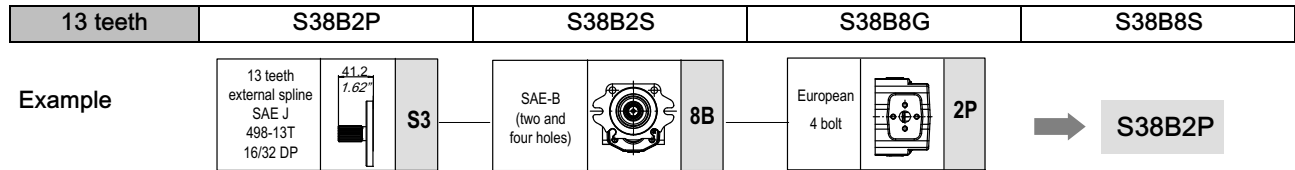

In the next pages: front flange, body/rear cover, and seals materials are listed for each motor series. For ordering purposes, it is enough to outline the complete motor description (for example: APM250HP/15 D S38B2P).

In case of a different configuration request (or a combination of different features, such as port threads, front flange materials, etc.), the description configurator shown in section 3.1 can be easily used.

2.1 Standard components configuration

Drive shaft			Cast iron flange			Cast iron body/back cover Port type		
13 teeth external spline SAE J 498-13T 16/32 DP $T_{max} = 270$ Nm		S3	SAE-B (two and four holes) (Ø101.6 mm - 4" inches)		8B	European 4 bolts flanged		2P
15 teeth external spline SAE J 498-15T 16/32 DP $T_{max} = 460$ Nm		S5	European rectangular (Ø50.8 mm - 2" inches)		1P	SAE FLANGED PORTS J518 (3000 PSI series)		2S
Straight keyed Ø 22.225 mm $T_{max} = 185$ Nm		C2				BSPP threaded ports		8G
Tapered 1:8 $T_{max} = 250$ Nm		C8	SAE threaded ports UNF		8S			

Serie	page	Serie	page	Serie	page	Serie	page
S38B2P - S58B2P	11	S38B2S - S58B2S	12	S38B8G - S58B8G	13	S38B8S - S58B8S	14
C81P2P	15	C81P8G	16				

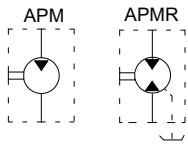

S38B2P
S58B2P

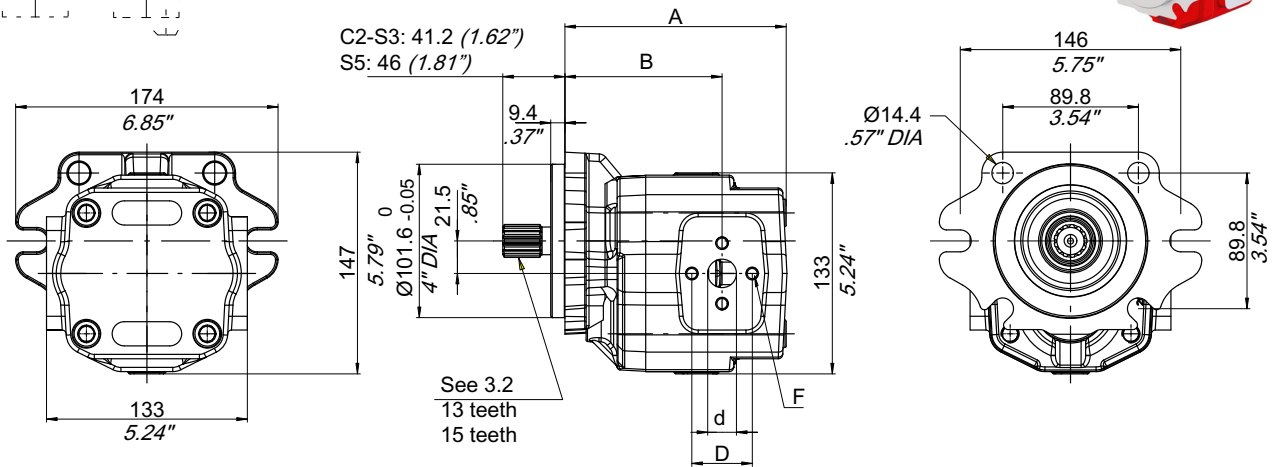
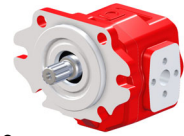

APMR External Drain

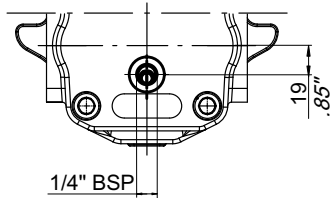

*In case of reversible motors, the smallest inlet/outlet ports available in the Catalog must be selected since they are both pressurizable (for any exceptions please consult Bucher Hydraulics)

Type	A		B		Outlet*			Inlet*						
	mm	inches	mm	inches	d	D	F	d	D	F				
15	128	5.04	85.5	3.37	19	.75	40	1.57	M8x1.25	19	.75	40	1.57	M8x1.25
19	132	5.20	89.5	3.52										
23	136	5.35	93.5	3.68										
26	139.5	5.49	97	3.82										
29	142.5	5.61	100	3.94										
33	146.5	5.77	104	4.09										
36	149.5	5.89	102	4.02	25	.98	51	2.01	M10x1.5	19	.75	40	1.57	M8x1.25
40	154	6.06	106.5	4.19										
45	159	6.25	111.5	4.39										
50	164	6.46	116.5	4.59										
54	168	6.61	120.5	4.74										

Motor description example:

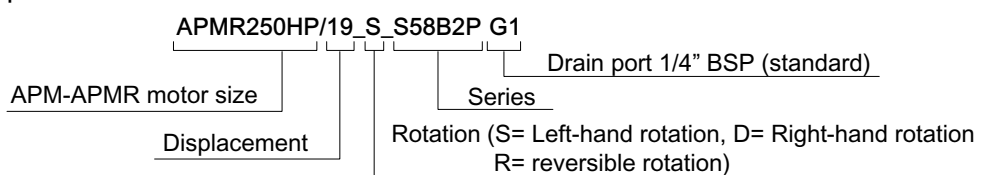

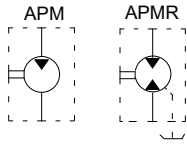

S38B2S
S58B2S

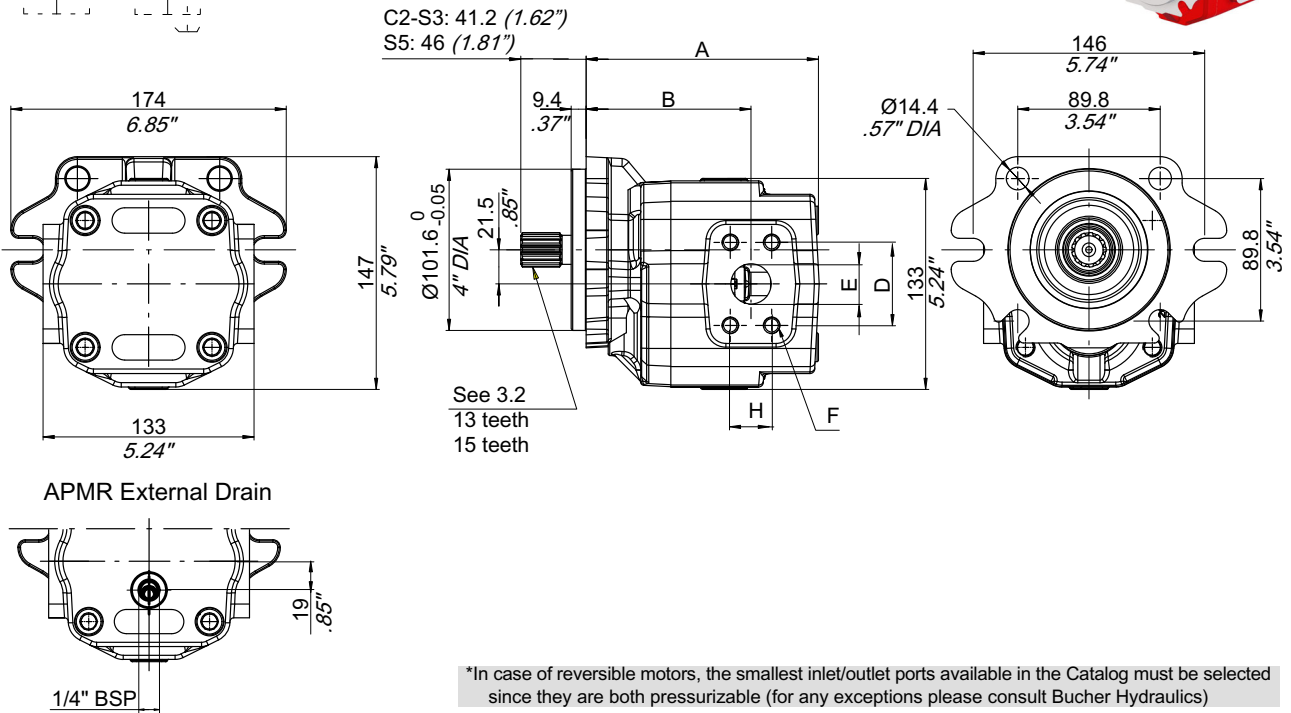

Type	A		B		Outlet*						Inlet*								
	mm	inches	mm	inches	H		D		E		F	H		D		E		F	
					mm	inch.	mm	inch.	mm	inch.	mm	mm	inch.	mm	inch.	mm	inch.	mm	
15	128	5.04	85.5	3.37															
19	132	5.20	89.5	3.52	26.19	1.03	52.37	2.06	25.4	1		22.23	.88	47.63	1.88	19	.75		
23	136	5.35	93.5	3.68															
26	139.5	5.49	97	3.82															
29	142.5	5.61	100	3.94															
33	146.5	5.77	104	4.09	30.17	1.19	58.72	2.31	31.8	1.25									
36	149.5	5.89	102	4.02															
40	154	6.06	106.5	4.19															
45	159	6.25	111.5	4.39															
50	164	6.46	116.5	4.59	35.71	1.14	69.85	2.75	38.1	1.5		26.19	1.03	52.37	2.06	25.4	1		
54	168	6.61	120.5	4.74															

Motor description example:

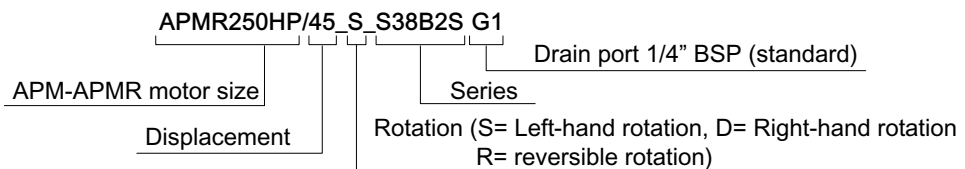

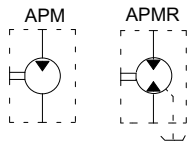

S38B8G
S58B8G

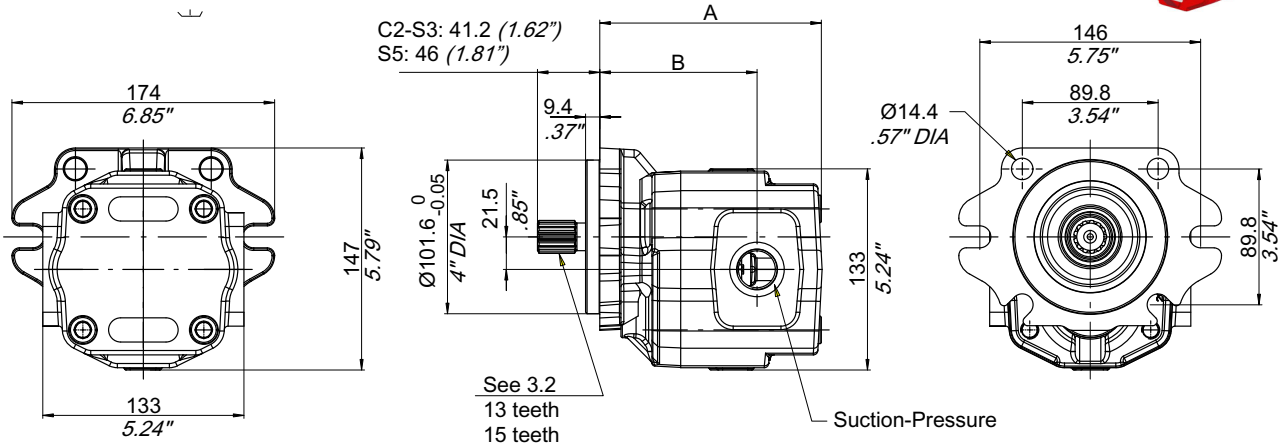
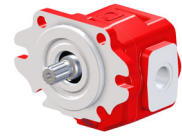

APMR External Drain

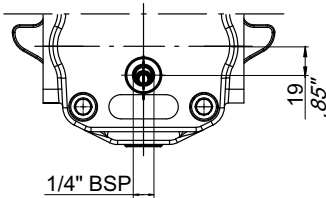

*In case of reversible motors, the smallest inlet/outlet ports available in the Catalog must be selected since they are both pressurizable (for any exceptions please consult Bucher Hydraulics)

Type	A		B		Outlet* BSPP	Inlet* BSPP
	mm	inches	mm	inches		
15	128	5.04	85.5	3.37	1"	3/4"
19	132	5.20	89.5	3.52		
23	136	5.35	93.5	3.68		
26	139.5	5.49	97	3.82		
29	142.5	5.61	100	3.94		
33	146.5	5.77	104	4.09		
36	149.5	5.89	102	4.02	1" 1/4	1"
40	154	6.06	106.5	4.19		
45	159	6.25	111.5	4.39		
50	164	6.46	116.5	4.59		
54	168	6.61	120.5	4.74		

Motor description example:

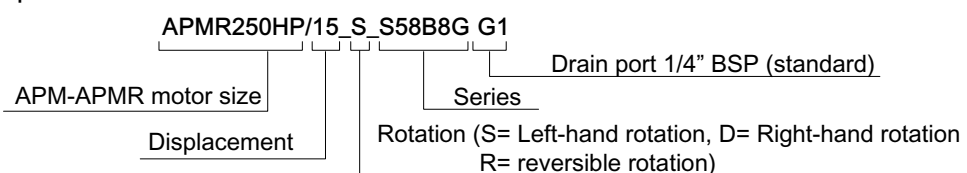

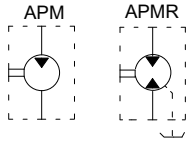

S38B8S
S58B8S

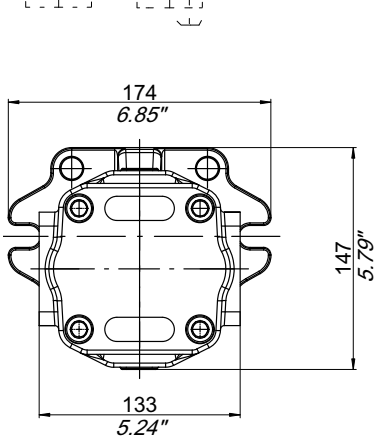
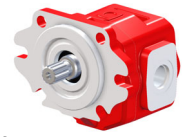

APMR External Drain

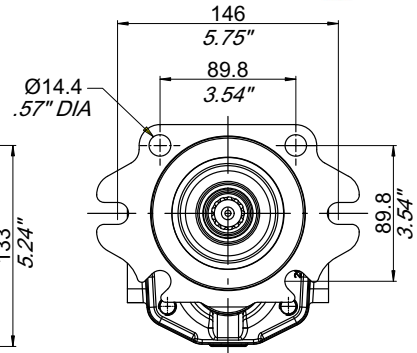
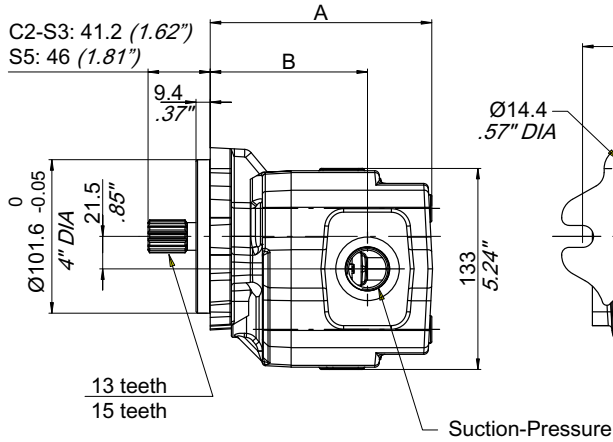
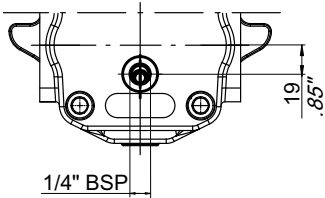

*In case of reversible motors, the smallest inlet/outlet ports available in the Catalog must be selected since they are both pressurizable (for any exceptions please consult Bucher Hydraulics)

Type	A		B		Outlet* UNF	Inlet* UNF
	mm	inches	mm	inches		
15	128	5.04	85.5	3.37	1" UNF-2B (SAE16)	3/4" UNF-2B (SAE12)
19	132	5.20	89.5	3.52		
23	136	5.35	93.5	3.68		
26	139.5	5.49	97	3.82		
29	142.5	5.61	100	3.94		
33	146.5	5.77	104	4.09	1 5/8" - 12 UNF-2B (SAE20)	1 5/16" - 12 UNF-2B (SAE16)
36	149.5	5.89	102	4.02		
40	154	6.06	106.5	4.19		
45	159	6.25	111.5	4.39		
50	164	6.46	116.5	4.59		
54	168	6.61	120.5	4.74		

Motor description example:

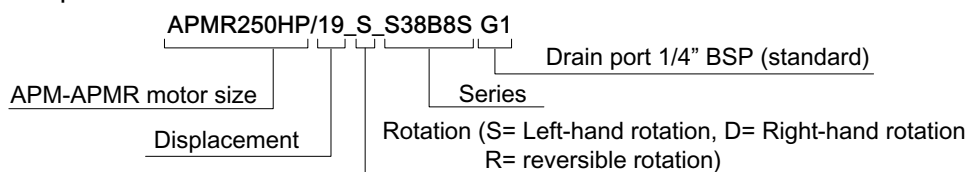

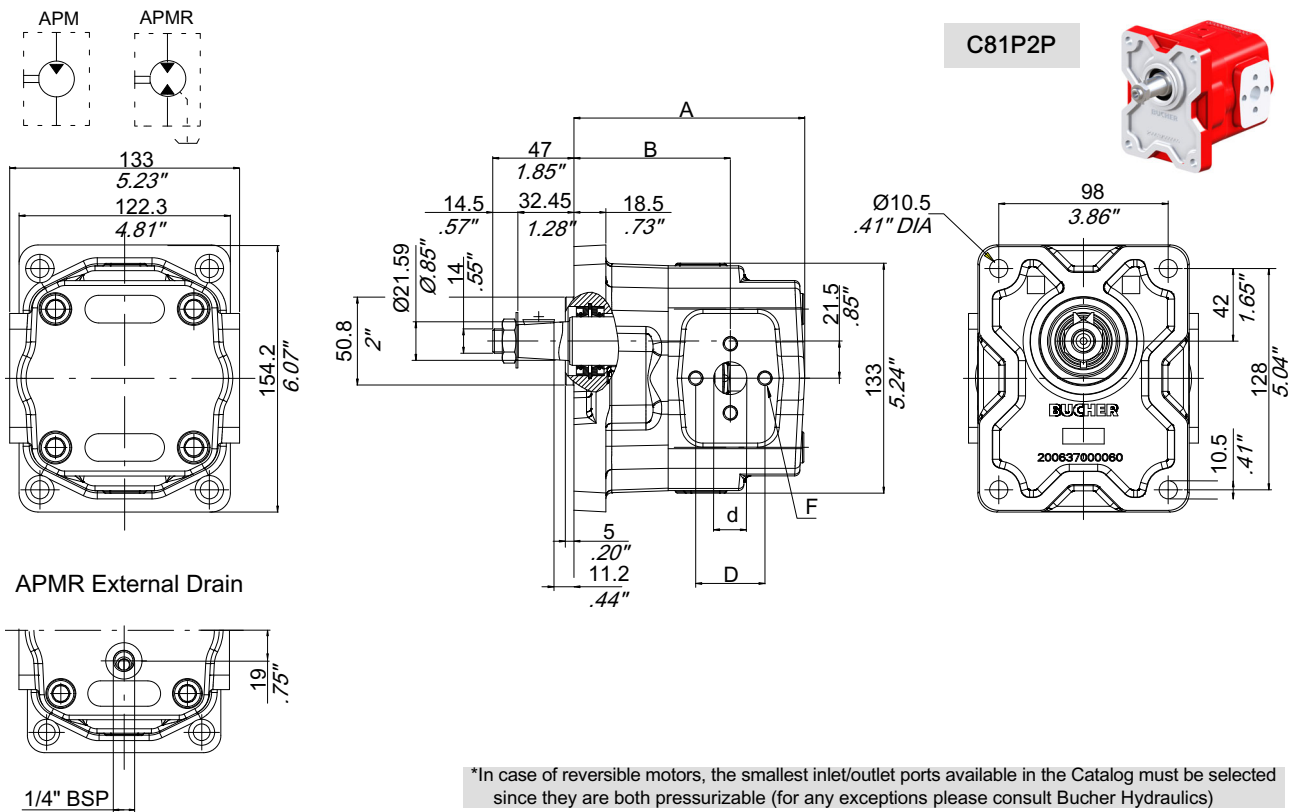

APMR External Drain

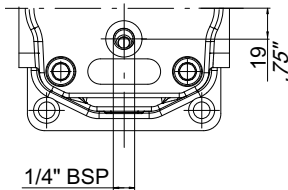

Type	A		B		Outlet*			Inlet*						
	mm	inches	mm	inches	d	D	F	d	D	F				
15	129	5.79	86.5	3.41	19	.75	40	1.57	M8x1.25	19	.75	40	1.57	M8x1.25
19	133	5.24	90.5	3.56										
23	137	5.39	94.5	3.72										
26	140.5	5.53	98	3.86										
29	143.5	5.65	101	3.98										
33	147.5	5.81	105	4.13										
36	150.5	5.93	103	4.06	25	.98	51	2.01	M10x1.5	19	.75	40	1.57	M8x1.25
40	155	6.10	107.5	4.23										
45	160	6.30	112.5	4.43										
50	165	6.50	117.5	4.63										
54	169	6.65	121.5	4.78										

Motor description example:

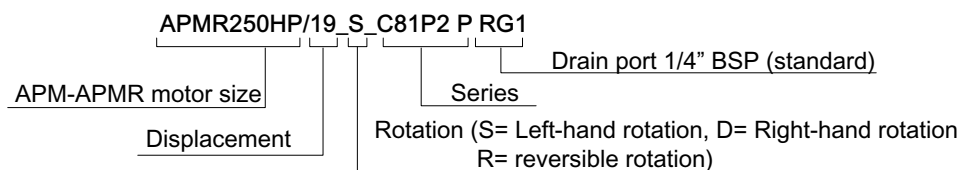

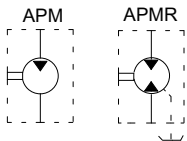

C81P8G

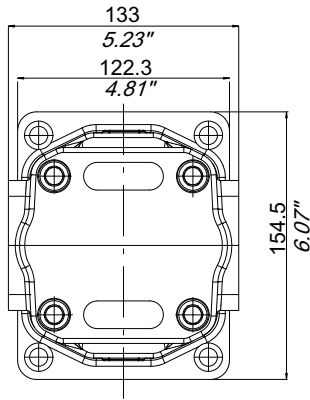
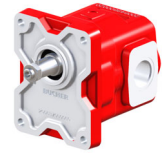

APMR External Drain

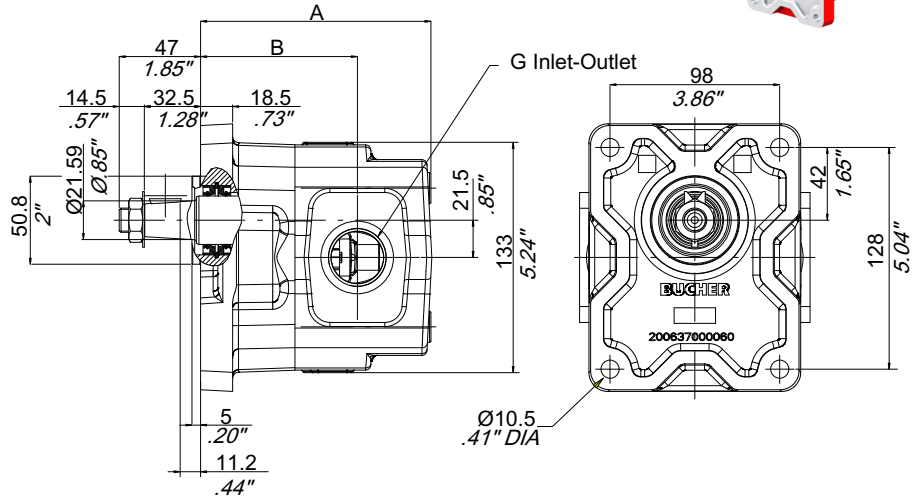
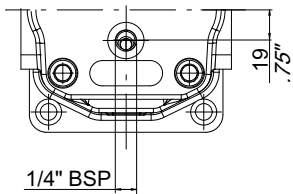

*In case of reversible motors, the smallest inlet/outlet ports available in the Catalog must be selected since they are both pressurizable (for any exceptions please consult Bucher Hydraulics)

Type	A	B	Outlet*	Inlet*
Type	mm	mm	BSPP	BSPP
15	129	86.5	1"	3/4"
19	133	90.5		
23	137	94.5		
26	140.5	98		
29	143.5	101		
33	147.5	105		
36	150.5	103	1" 1/4	1"
40	155	107.5		
45	160	112.5		
50	165	117.5		
54	169	121.5		

Motor description example:

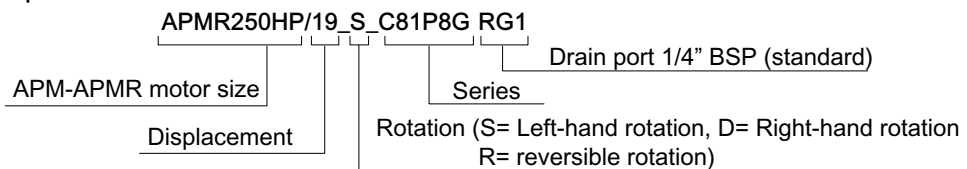

3 APM250HP Customised versions

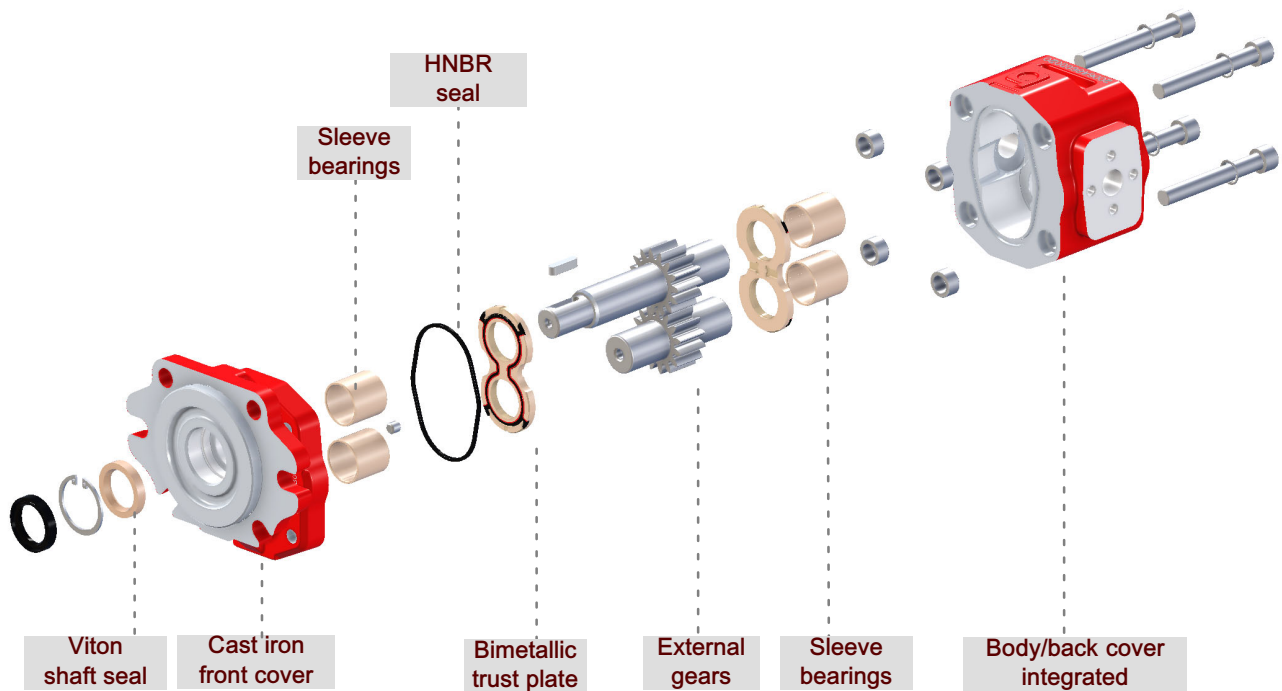

In this section, APMR250HP motor can be configured and customized.

APMR250HP wide availability of covers, bodies and gears provides great flexibility to APMR250HP motor range and allows several different motor configurations.

In order to simplify the selection of the desired motor combination, a 'configurator form' is available and, by filling it out, it will guide you in the motor creation process.

3.1 Single motor customised versions order example

A	P	M	2	5	0	H	P	/	1	5	-	S	-	S	3	8	B	8	G	A	-												*
---	---	---	---	---	---	---	---	---	---	---	---	---	---	---	---	---	---	---	---	---	---	--	--	--	--	--	--	--	--	--	--	--	---

Function

APM= gear motor - unidirectional
APMR= gear motor - bidirectional-unidirectional

Series

250HP

Displacement

15= 15.2 cm³/rev
19= 19.1 cm³/rev
23= 23 cm³/rev
26= 26.4 cm³/rev
29= 29.3 cm³/rev
33= 33.2 cm³/rev
36= 36.1 cm³/rev
40= 40.5 cm³/rev
45= 45.3 cm³/rev
50= 50.2 cm³/rev
54= 54 cm³/rev

Rotation

S = Left-hand rotation
D = Right-hand rotation
Omitted if reversible version

Shaft end code

see section 3.2

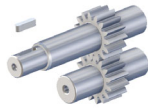

Front cover type

see section 3.3.1

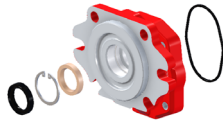

Type of ports code

see section 3.3.2

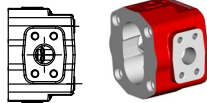

Inlet/outlet port size code combination

see section 3.3.2



Circuits/Valves option

Example of several hydraulic circuits are available on demand (please consult Bucher Hydraulics)

BHRE section :

Version - Progressive number (omitted)

3.2 Shaft end code

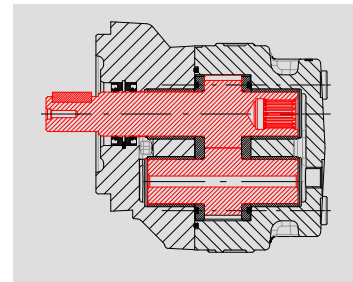
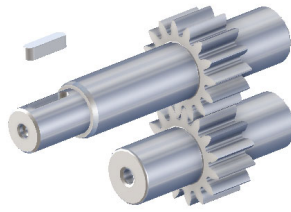

A P M 2 5 0 H P / 1 5 - S - S 3

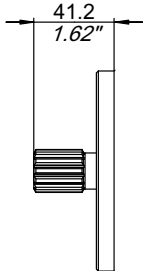
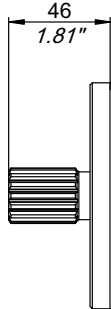
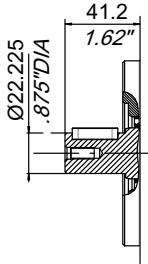
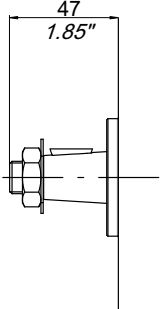
Shaft end shape	Shaft end ordering code	Max torque
 <p>41.2 1.62"</p> <p>13 teeth external spline SAE J 498-13T 16/32 DP</p>	S3	$T_{max} = 270 \text{ Nm}$
 <p>46 1.81"</p> <p>15 teeth external spline SAE J 498-15T 16/32 DP</p>	S5	$T_{max} = 460 \text{ Nm}$
 <p>41.2 1.62"</p> <p>Ø22.225 .875" DIA</p> <p>Straight keyed Ø 22.225 mm - 0.875 inches</p>	C2	$T_{max} = 185 \text{ Nm}$
 <p>47 1.85"</p> <p>Tapered 1:8</p>	C8	$T_{max} = 250 \text{ Nm}$

3.3 Front cover/mounting flange

3.3.1 Front cover type

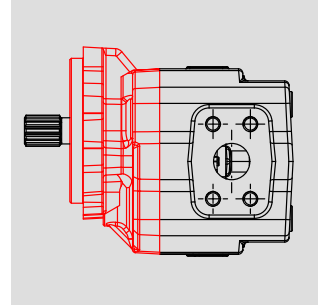
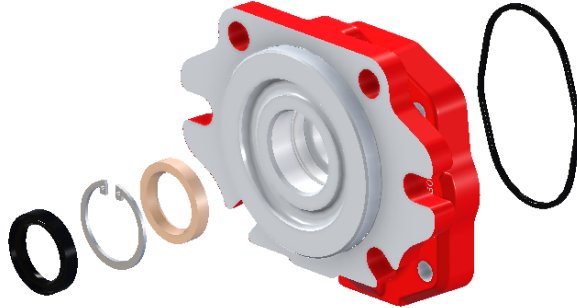

A P M 2 5 0 H P / 1 5 - S - S 3 8 B



Type	Cast iron	
	Shape	Ordering code
SAE-B Two and four bolts (Ø 101.6 mm - 4 inches) with Viton shaft seal		8B
European rectangular (Ø50.8 mm - 2" inches) with Viton shaft seal		1P

3.3.2 Body type

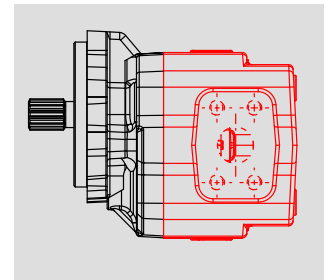
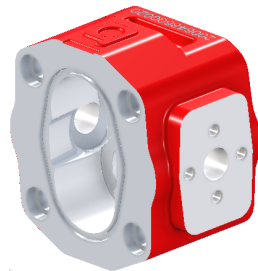

A P M 2 5 0 H P / 1 5 - S - S 3 8 B 8 G A

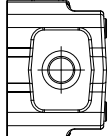
Port type	Ordering code	Displacement	Dimension (mm - inches)		Ordering code
			Outlet	Inlet	
 BSP Ports	8G	15-33	1" BSP	3/4" BSP	A
		36-54	1 1/4" BSP	1" BSP	B

3/4" BSP

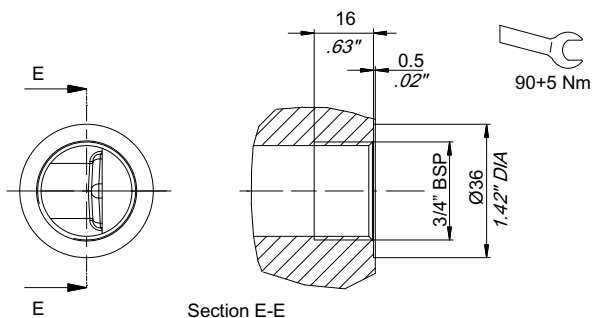

1" BSP

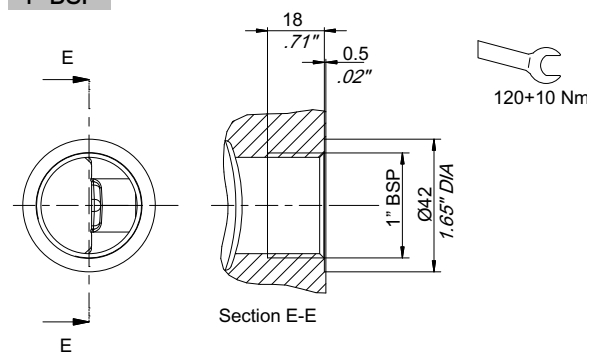

1 1/4" BSP

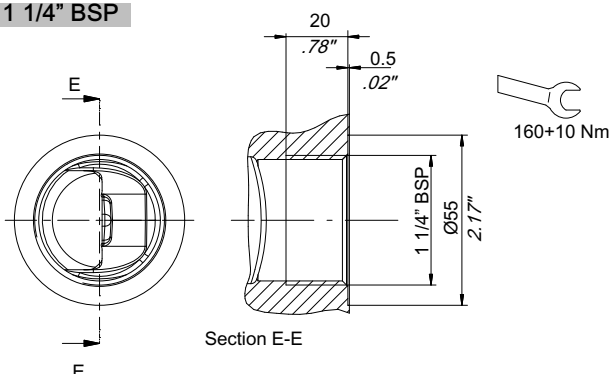

IMPORTANT!: Tightening torques depends on several different factors including lubrication, coating and surfaces finish. The fitting manufacturer shall be consulted.
 In the interest of safety, only fittings with STRAIGHT THREAD ENDS should be used (e.g. DIN3852).
 Fittings with TAPERED THREAD ENDS (e.g. DIN 3852 form C) should never be used, as they can cause deformation and cracks in the valve body.
 Our warranty conditions will not be valid in case tapered fittings are used.
 The work port adaptors have to be fastened respecting the tightening torque values indicated.

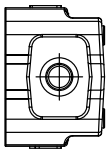
Port type	Ordering code	Displacement	Dimension (mm - inches)		Ordering code
			Outlet	Inlet	
	8S	15-33	1" UNF-2B (SAE16)	3/4" UNF-2B (SAE12)	A
		36-54	1 5/8"-12 UNF-2B (SAE20)	1 5/16"-12 UNF-2B (SAE16)	B

3/4" UNF-2B (SAE12)

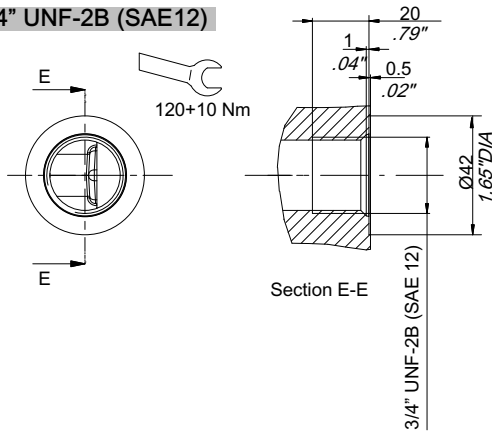

1" UNF-2B (SAE16)

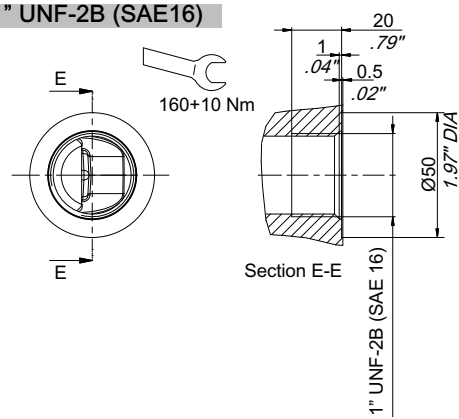

1 5/8"-12 UNF-2B (SAE20)

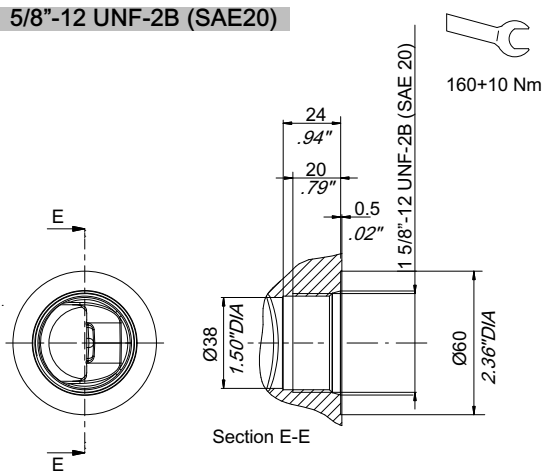

1 5/16" 12 UNF-2B (SAE16)

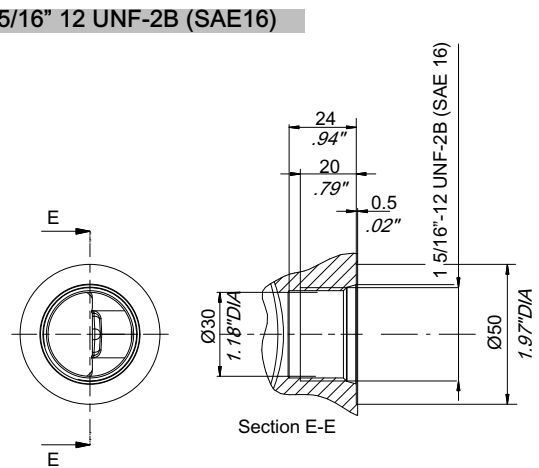

IMPORTANT!: Tightening torques depends on several different factors including lubrication, coating and surfaces finish. The fitting manufacturer shall be consulted.

Port type	Ordering code	Displacement	Dimension (mm - inches)						Ordering code	
			Outlet			Inlet				
			d	D	F	d	D	F		
	European n 4 bolt	2P	15-33	19 .75	40 1.57	M8x1.25	19 .75	40 1.57	M8x1.25	A
			36-54	25 .98	51 2.01	M10x1.5	19 .75	40 1.57	M8x1.25	B

2PA

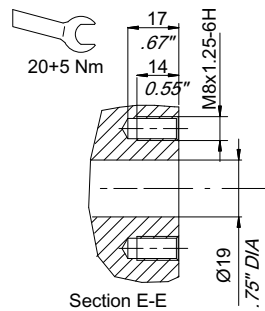
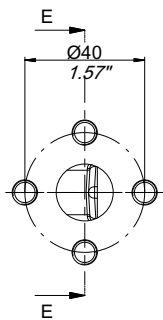

2PB

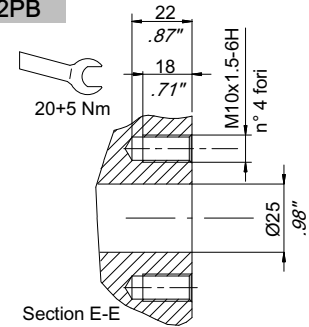
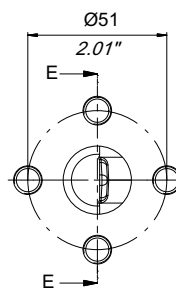

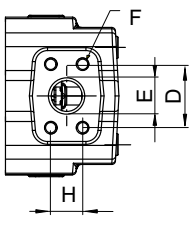
Port type	Ordering code	Displacement	Dimension (mm - inches)								Ordering code
			Outlet				Inlet				
			H	D	E	F	H	D	E	F	
 <p>SAE FLANGED PORTS J518 (3000 PSI series)</p>	2S	15-23	26.19 1.03	52.37 2.06	25.4 1	M10 x1.5	22.23 .88	47.63 1.88	19 .75	M10 x1.5	A
		26-40	30.17 1.19	58.72 2.31	31.8 1.25		26.19 1.03	52.37 2.06	25.4 1		B
		45-54	35.71 1.14	69.85 2.75	38.1 1.5	M12 x1.75				C	

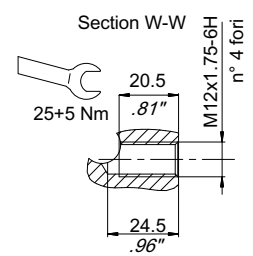
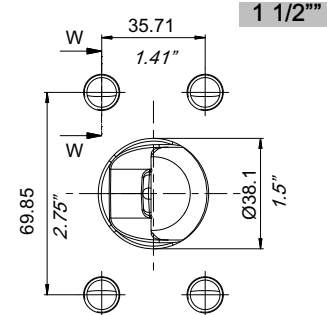
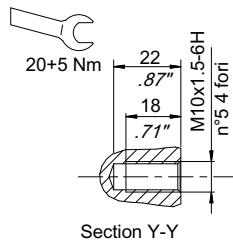
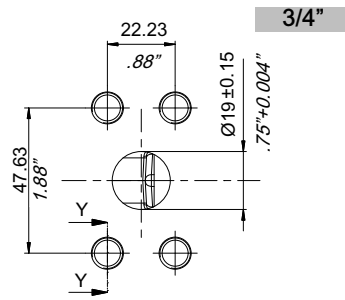
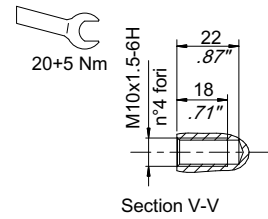
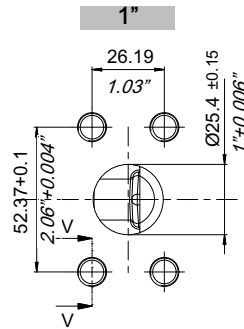
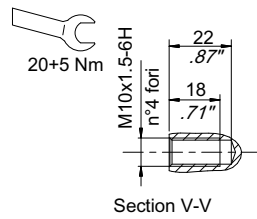
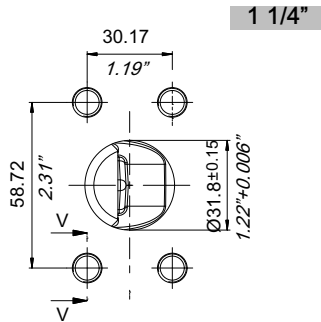

Other ports	9	If the requested port type is not included in the previous versions, please indicate number "9" and specify the details in the request note
-------------	---	---

3.3.2.1 Cast iron body with rear drain port for SAE-B flange

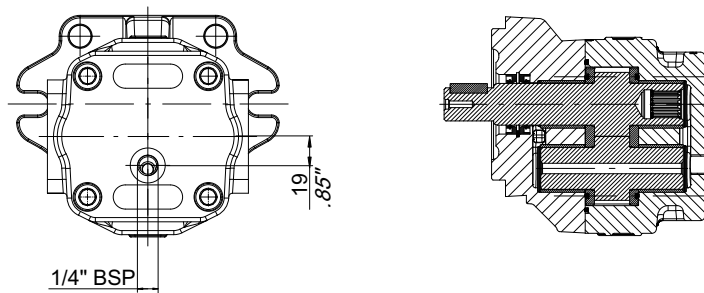

A P M R 2 5 0 H P / 1 5 - C 2 8 B - 2 P A - G 1

Type	Thread	Tightening torque	Ordering code
Rear drain line	1/4" BSP	30 ⁻⁶ ₊₇ Nm	G1 (standard)
	SAE4	20 ⁻⁵ ₊₅ Nm	G2
	M12x1.5	30 ⁻⁶ ₊₇ Nm	G3

3.3.2.2 Cast iron body with rear or lateral (right) drain port for European front cover

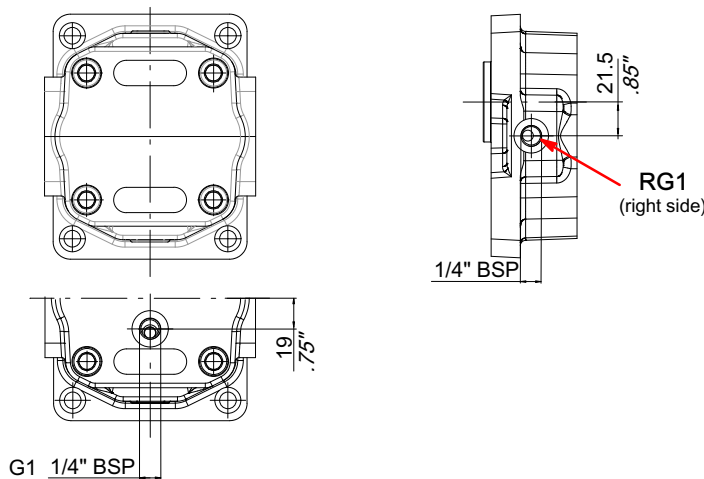

A P M R 2 5 0 H P / 1 5 - C 8 1 P - 2 P A - G 1

Type	Thread	Tightening torque	Ordering code
Rear drain line	1/4" BSP	30 ⁻⁶ ₊₇ Nm	G1 (standard)
	SAE4	20 ⁻⁵ ₊₅ Nm	G2
	M12x1.5	30 ⁻⁶ ₊₇ Nm	G3

A P M R 2 5 0 H P / 1 5 - C 8 1 P - 2 P A - R G 1

Type	Thread	Tightening torque	Ordering code
Lateral (right) drain line	1/4" BSP	30 ⁻⁶ ₊₇ Nm	RG1 (standard)
	SAE4	20 ⁻⁵ ₊₅ Nm	RG2
	M12x1.5	30 ⁻⁶ ₊₇ Nm	RG3

4 Product identification plate

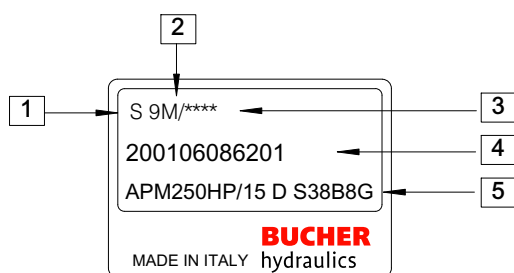

- 1 : Rotation (D= Clockwise rotation -
S= Counterclockwise rotation -
R= Reversible rotation)
- 2 : Manufacturing year and month
- 3 : Progressive identification no. (optional)
- 4 : Bucher Hydraulics S.p.A. product code
- 5 : Description

Manufacturing month	Manufacturing year				
	2018	2019	2020	2021	2022
January	8M	9M	0M	1M	2M
February	8N	9N	0N	1N	2N
March	8P	9P	0P	1P	2P
April	8Q	9Q	0Q	1Q	2Q
May	8R	9R	0R	1R	2R
June	8S	9S	0S	1S	2S
July	8T	9T	0T	1T	2T
August	8U	9U	0U	1U	2U
September	8V	9V	0V	1V	2V
October	8Z	9Z	0Z	1Z	2Z
November	8X	9X	0X	1X	2X
December	8Y	9Y	0Y	1Y	2Y

5 Application form

Date:			
Contact:			
Customer:			
Location:			
Overall quantity per year:			
Minimum batch size:			
Delivery time requested:	Feasibility:	Prototypes:	Series:
Target price:			
Type of application:			

External gear motor general data						
Rotation	S	D	R	Oil temperature (°C)	min	max
Displacement of the motor (cm ³ /rev)				Oil viscosity (cSt)	min	max
Drive shaft				Outlet line pressure		
Port type				Drain case pressure		
Front cover type				Radial load (N)		
Speed range				Axial load (N)		
Continuous work pressure (bar)				Working hours per year		
Peak work pressure (bar)				Cycles per year		
Oil type						

Additional notes:						

info.it@bucherhydraulics.com

www.bucherhydraulics.com

© 2020 by Bucher Hydraulics S.p.A, I-42124 Reggio Emilia

All rights reserved.

Data is provided for the purpose of product description only, and must not be construed as warranted characteristics in the legal sense. The information does not relieve users from the duty of conducting their own evaluations and tests. Because the products are subject to continual improvement, we reserve the right to amend the product specifications contained in this catalogue.

Classification: 410.110.000