

AIR OPERATED DIRECTIONAL CONTROL VALVE
N,0, DIRECT ACTING, SPOOL TYPE (2/2)

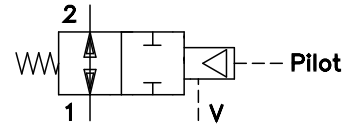

TORQUE:

Steel = 55/60 Ft-Lb. [74/81 Nm]

Aluminum = 35/40 Ft-Lb. [47/54 Nm]

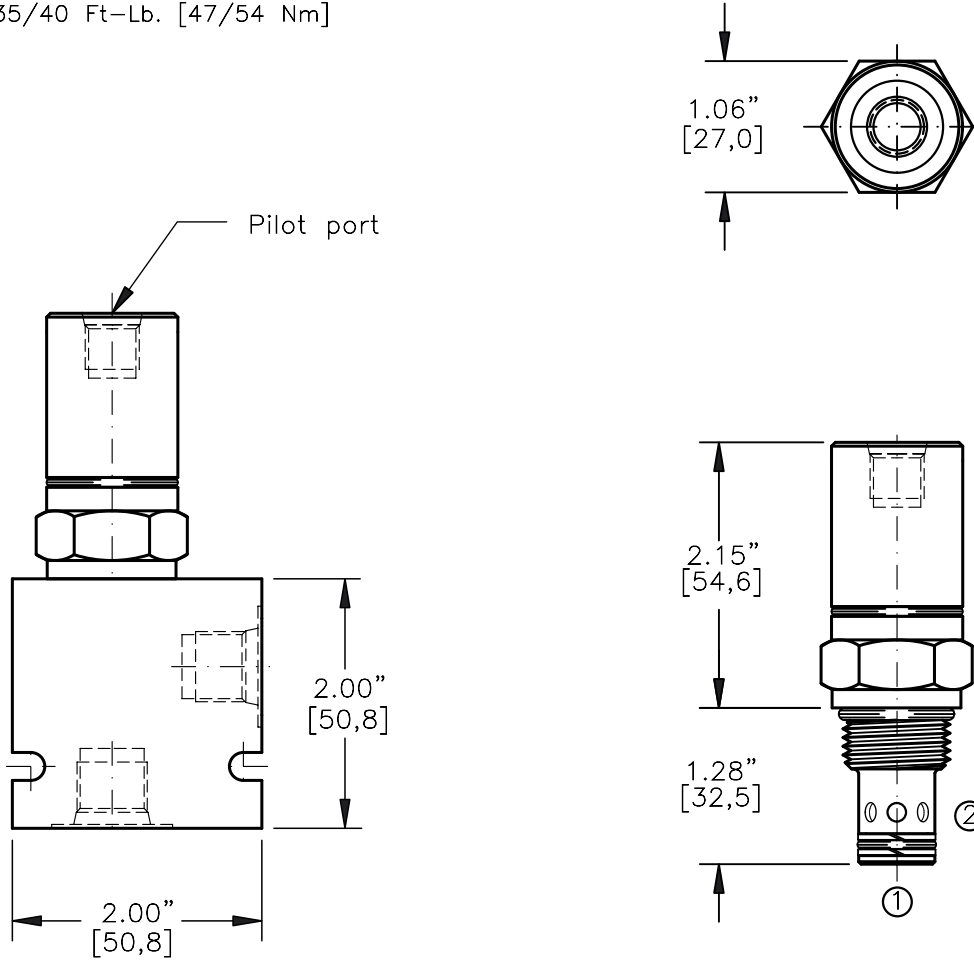

FOR ALUMINUM OR STEEL VALVE HOUSING CONFIGURATIONS SEE PAGE 0-012.1

AODV-10-X-O1-X-XX

- BASIC
- SIZE
10 = 7/8"-14 UNF
- TYPE
N = BUNA "N"
V = VITON
- SPOOL
O1=NORMALLY OPEN SPOOL
2-WAY, 2-POSITION
- PILOT PORT
1P = 1/8" NPTF
1B = G 1/8" BSPP
4T = SAE - #4
- PORTS
0 = CARTRIDGE ONLY
02BX = G 1/4" BSPP
03BX = G 3/8" BSPP
06TX = SAE - #6
08TX = SAE - #8
- "A" - ALUM. HOUSING
"S" - STEEL HOUSING

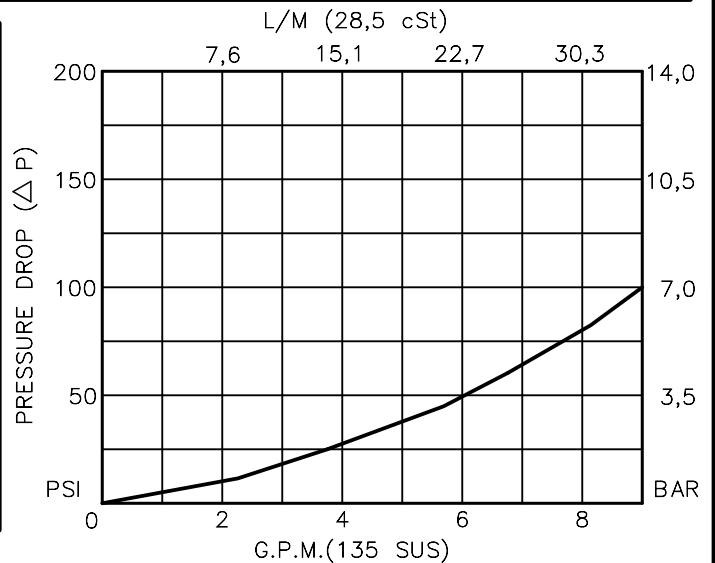

**AIR OPERATED, NORMALLY OPEN,
DIRECT ACTING, SPOOL TYPE (2/2)****DESCRIPTION**

This unit is a NORMALLY OPEN, TWO POSITION, screw-in cartridge style, direct acting spool type, air or hydraulic operated, spring return, hydraulic directional control valve.

OPERATIONS

When pilot piston is not actuated, this valve allows flow between ports 2 to 1.

When pilot piston is pressurized, the spool in this valve is shifted and allows no flow between ports 2 to 1.

Port #1 can be pressurized to 18.5 x PILOT PORT pressure.

FEATURES AND BENEFITS

Hardened precision fitted spool & sleeve provides reliable, long life. Corrosion free pilot piston assembly allows this valve to be operated by air or any type of hydraulic fluids.

Pilot piston is isolated from hydraulic fluid with high pressure seals.

All external carbon steel parts are plated for longer life against the elements.

All cartridge valves are 100% functionally tested.

Industry common cavity.

SPECIFICATIONS

OPERATING PRESSURE: 5,000 PSI [350 Bar]

PROOF PRESSURE: 10,000 PSI [700 Bar]

FLOW: 8.0 GPM [30 l/m] See performance chart.

INTERNAL LEAKAGE: 5 cu.in/min [82 cc/m] @ 5,000 PSI [350 Bar]

VALVE HOUSINGS: 2500 PSI [175 Bar] = Aluminum – Anodized.

5000 PSI [350 Bar] = Steel – Unplated.

OPERATING TEMPERATURE: -40° to +250° F. [-40° to +120° C.]

OPERATING MEDIA: All general purpose hydraulic fluids such as MIL-H-5606, SAE-#10, SAE-#20, etc.

PILOT OPERATING MEDIA: Air or hydraulic fluid.

PILOT PISTON AREA RATIO TO SYSTEM PRESSURE AREA IS: 18.5 to 1.

PILOT OPERATING PRESSURE IS: 50 PSI to 250 PSI air.

50 PSI to 1000 PSI hydraulic.

SEAL KIT: SKN-1022 Buna "N"

SKV-1022 Viton

INSTALLATION: No restrictions.

WEIGHT: 0.54 lb [0,27 kg] cartridge only.

VALVE CAVITY: #C1020, See Page 0-012.0.

info.el@bucherhydraulics.com

www.bucherhydraulics.com/commoncavity

© 2015 by Bucher Hydraulics, Inc., 2545 Northwest Parkway, Elgin, Illinois 60124, USA

All rights reserved.

Data is provided for the purpose of product description only, and must not be construed as warranted characteristics in the legal sense. The information does not relieve users from the duty of conducting their own evaluations and tests. Because the products are subject to continual improvement, we reserve the right to amend the product specifications contained in this catalogue.