

CHECK VALVE FORWARD GUIDED BALL

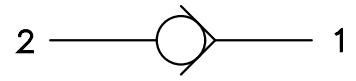

TORQUE:

Steel = 55/60 Ft-Lb. [74/81 Nm]  
Aluminum = 35/40 Ft-Lb. [47/54 Nm]

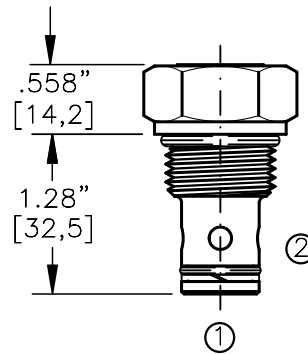
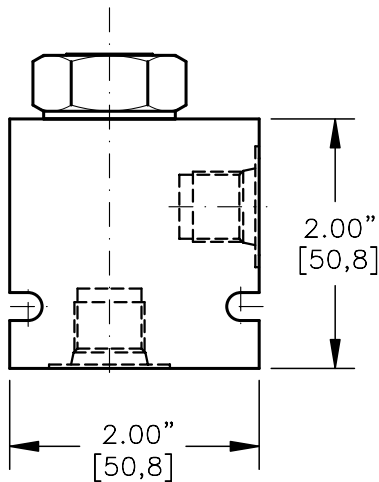
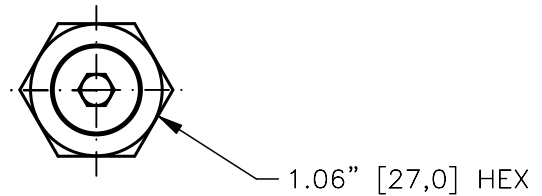

FOR ALUMINUM OR STEEL VALVE HOUSING CONFIGURATIONS SEE PAGE 0-012.1

**CVFB-10-X-X-XXX**

- BASIC
- SIZE  
10 = 7/8" - 14 UNF
- SEALS  
N = BUNA "N"  
V = VITON
- PORTS  
0 = CARTRIDGE ONLY  
02BX = G 1/2" BSPP  
03BX = G 3/4" BSPP  
06TX = SAE - #10  
08TX = SAE - #12
- "A" - ALUM. HOUSING  
"S" - STEEL HOUSING
- CRACK PRESSURE  
005 = 5 PSI  
015 = 15 PSI  
030 = 30 PSI  
060 = 60 PSI  
120 = 120 PSI

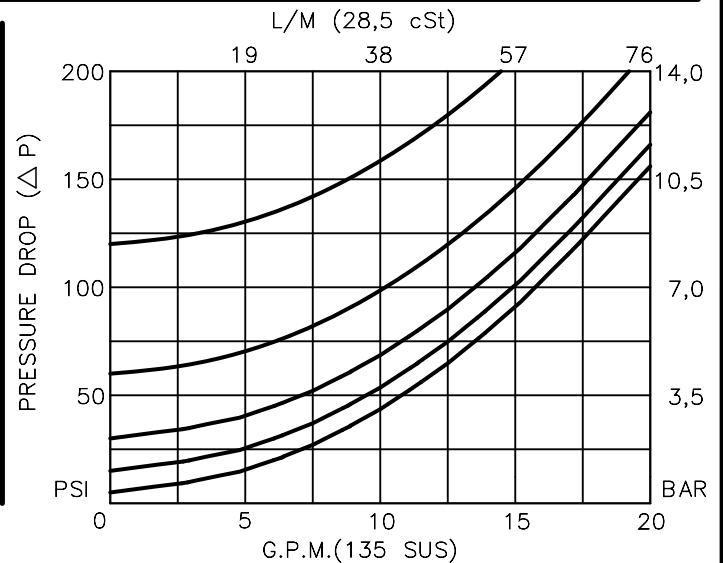

## CHECK VALVE FORWARD GUIDED BALL

### DESCRIPTION

This unit is a SCREW IN, cartridge type, guided ball, hydraulic check valve, for use as a blocking or load holding device for high pressure applications.

### OPERATIONS

This valve allows free flow from port 1 to port 2 and blocks flow from port 2 to port 1 for holding a load.

### FEATURES AND BENEFITS

Wide selection of bias springs allows flexibility for back-pressure application.

All external parts are zinc plated for longer life against the elements.

All cartridge valves are 100% functionally tested.

Industry common cavity.

### SPECIFICATIONS

OPERATING PRESSURE: 5,000 PSI [350 Bar]

PROOF PRESSURE: 10,000 PSI [700 Bar]

FLOW: 18.0 GPM [68 l/m] nominal. See performance chart.

INTERNAL LEAKAGE: 5 drops per minute maximum @ 5,000 PSI [350 Bar]

VALVE HOUSINGS: 2500 PSI [175 Bar] = Aluminum – Anodized.

5000 PSI [350 Bar] = Steel – Unplated.

OPERATING TEMPERATURE: -40° to +250° F. [-40° to +120° C.]

OPERATING MEDIA: All general purpose hydraulic fluids such as MIL-H-5606, SAE-#10, SAE-#20, etc.

INSTALLATION: No restrictions.

SEAL KIT: SKN-1021 Buna "N"

SKV-1021 Viton

WEIGHT: .25 lb [.12 kg] cartridge only.

VALVE CAVITY: #C1020, See Page 0-012.0.

[info.el@bucherhydraulics.com](mailto:info.el@bucherhydraulics.com)

[www.bucherhydraulics.com/commoncavity](http://www.bucherhydraulics.com/commoncavity)

© 2015 by Bucher Hydraulics, Inc., 2545 Northwest Parkway, Elgin, Illinois 60124, USA

All rights reserved.

Data is provided for the purpose of product description only, and must not be construed as warranted characteristics in the legal sense. The information does not relieve users from the duty of conducting their own evaluations and tests. Because the products are subject to continual improvement, we reserve the right to amend the product specifications contained in this catalogue.