

SOLENOID VALVE, 3-WAY, 2-POSITION
CLOSED CENTER, SPOOL TYPE (3/2)

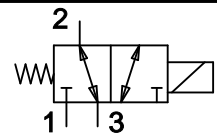

TORQUE:

Steel = 35/40 Ft-Lb. [47/54 Nm]
Aluminum = 25/30 Ft-Lb. [34/41 Nm]

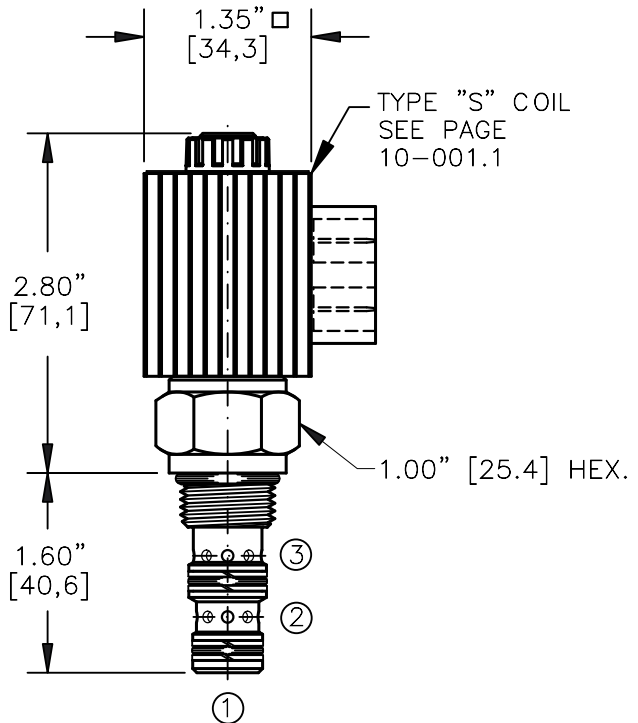
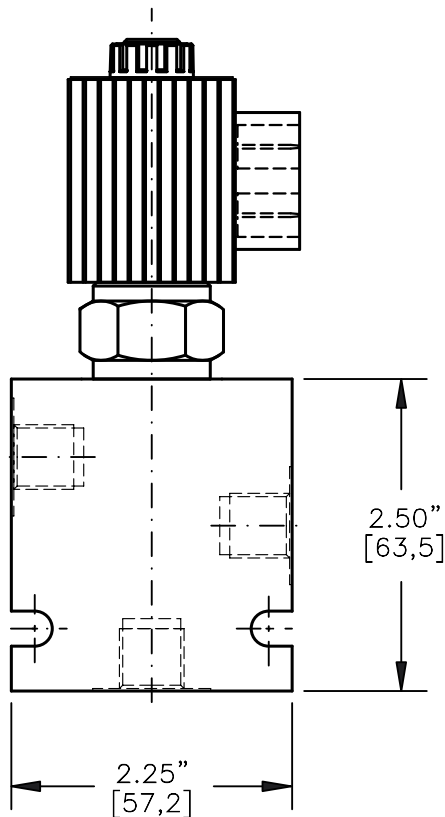

NOTES:

1. FOR ALUMINUM OR STEEL VALVE HOUSING CONFIGURATIONS SEE PAGE 0-031.1
2. SOLENOIDS AVAILABLE WITH DIODES - CONSULT FACTORY.
3. FOR "AC" COILS USE RECTIFIED DIN CONNECTOR 20828.

EMDV-08-X-3N-X-XXX X

BASIC

SIZE
08 = 3/4"-16UNF

SEALS
N = BUNA "N" = VITON
V

TYPE
3N = "N" SPOOL
3-WAY, 2-POSITION

PORTS
0 = CARTRIDGE ONLY
02BX = G 1/4" BSSP
06TX = SAE - #6

"A" = ALUM. HOUSING
"S" = STEEL HOUSING

TERMINALS

L = 18GA. 24" LEADS
T = SPADE TERM.
B = BOLT TERM.
G = DIN43650
W = WEATHER-PACK
D = DEUTSCH-DT04-2P
M = METRI-PACK CONN.

VOLTAGE AMPS

12D = 12 VDC 1.7
24D = 24 VDC .9
36D = 36 VDC .6
48D = 48 VDC .5
115D = 115 VDC .2

L/M (28,5 cSt)

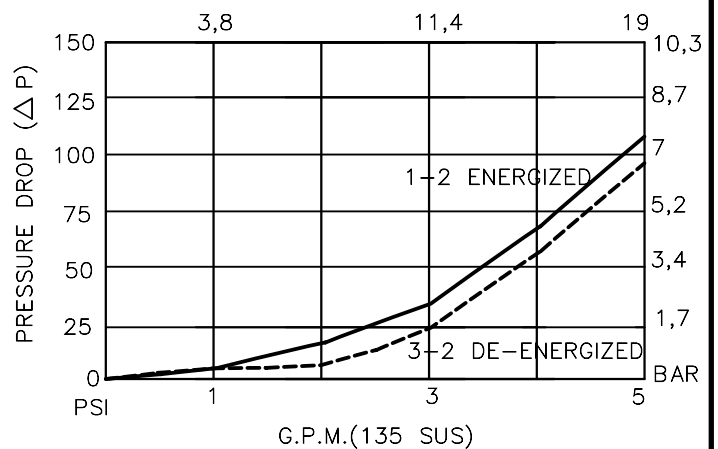

**SOLENOID VALVE 3-WAY, 2-POSITION,
CLOSED CENTER, SPOOL TYPE (3/2)****DESCRIPTION**

This unit is a THREE-WAY, TWO POSITION, cartridge type, spool type, direct acting, screw in type, solenoid operated, directional control valve.

OPERATIONS

When solenoid coil is de-energized, this valve allows flow between ports 2 and 3 and port 1 is blocked. When solenoid coil is energized, the spool in this valve is shifted and allows flow between ports 1 and 2 and port 3 is blocked. This valve shifts in a closed position.

FEATURES AND BENEFITS

Continuous-duty, very low heat rise & waterproof solenoid coil.
Interchangeable solenoid coils & terminations options available.
Hardened precision fitted spool & sleeve provides reliable, long life.
Very efficient, wet-armature solenoid core tube construction.
All external carbon steel parts are plated for longer life against the elements.
All cartridge valves are 100% functionally tested.
Industry common cavity.

SOLENOID VALVE 3-WAY, 2-POSITION, CLOSED CENTER, SPOOL TYPE (3/2)

SPECIFICATIONS

OPERATING PRESSURE: 5,000 PSI [350 Bar]

PROOF PRESSURE: 10,000 PSI [700 Bar]

FLOW: 5.0 GPM [19 l/m] See performance chart.

INTERNAL LEAKAGE: 5 cu.in/min [82 cc/m] @ 5,000 PSI [350 Bar]

VALVE HOUSINGS: 2500 PSI [175 Bar] = Aluminum - Anodized.

5000 PSI [350 Bar] = Steel - Unplated.

OIL TEMPERATURE: -40° to +175° F. [-40° to +80° C.]

AMBIENT TEMPERATURE: -40° to +122° F. [-40° to +50° C.]

Please consult factory for continuously energized or
high ambient temperature application (>122° F [50°C])

OPERATING MEDIA: All general purpose hydraulic fluids such as
MIL-H-5606, SAE-#10, SAE-#20, etc.

RESPONSE TIME: First indication of change in pressure with 100%
voltage supplied @ 80% of nominal flow rating.

* Pull-in: 50 ms

* Drop-Out: 50 ms

SEAL KIT: SKN-0832 Buna "N"

SKV-0832 Viton

INSTALLATION: No restrictions.

WEIGHT: .95 lb [0.43 kg] cartridge with coil only.

VALVE CAVITY: #C0830, See Page 0-031.0.