

HOT OIL SHUTTLE VALVE SPOOL TYPE, SPRINGLESS WITH RELIEF VALVE

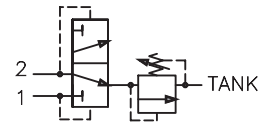

TORQUE:

Steel = 55/60 Ft-Lb. [74/81 Nm]

Aluminum = 35/40 Ft-Lb. [47/54 Nm]

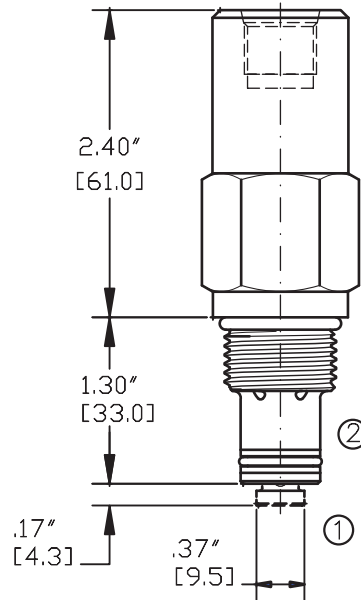
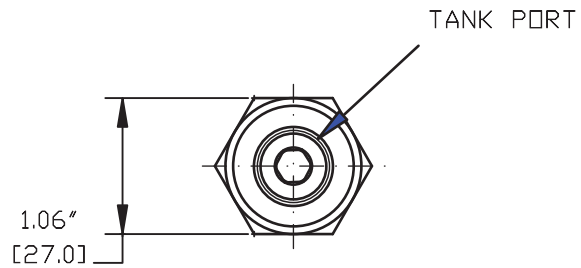
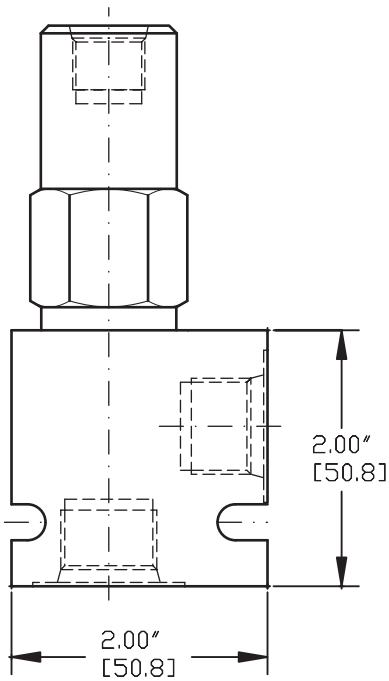

NOTE: CAVITY BOTTOM HOLE MUST ALLOW FOR POPPET EXTENSION (.500 DIA)
FOR ALUMINUM OR STEEL VALVE HOUSING CONFIGURATIONS SEE PAGE 0-012.1

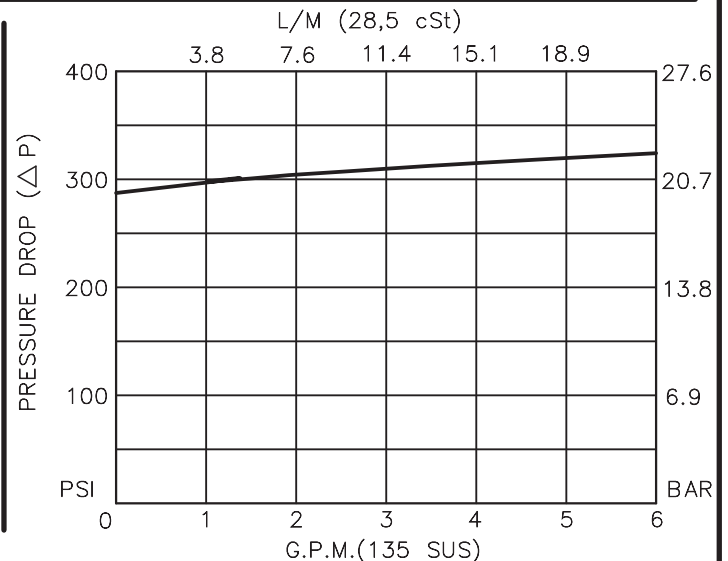
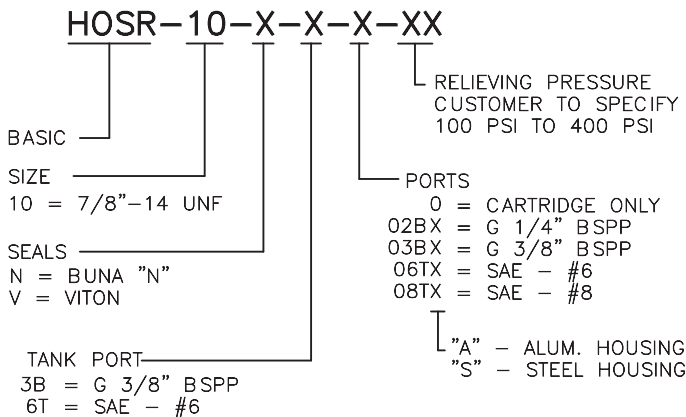

HOT OIL SHUTTLE VALVE, SPOOL TYPE, SPRINGLESS WITH RELIEF VALVE

DESCRIPTION

This unit is a DIRECT ACTING, SCREW IN CARTRIDGE STYLE, SPOOL TYPE, HYDRAULIC 3-WAY, 2 POS. DIRECTIONAL SHUTTLE VALVE, with built-in ADJUSTABLE RELIEF VALVE which may be used on a hydrostatic transmission to direct charge pump oil to heat exchanger or to tank.

OPERATIONS

This valve with its internal pilots at port 1 or port 2 will allow flow to tank port from the opposite port which is piloted with high pressure, thus removing oil from the low pressure side for cooling or filtration purposes. This valve is springless therefore relying solely on the internal pressure signal to shift it to either side.

This valve has a built-in internally adjustable (100 to 400 PSI) relief valve.

FEATURES AND BENEFITS

Hardened precision fitted spool and cage provides reliable, long life. A unibody cage construction provides very low hysteresis and reliable operation.

All external carbon steel parts are plated for longer life against the elements. All cartridge valves are 100% functionally tested. Industry common cavity.

SPECIFICATIONS

OPERATING PRESSURE: 5,000 PSI [350 Bar]

PROOF PRESSURE: 10,000 PSI [700 Bar]

FLOW: 6.0 GPM [22,8 L/M] nominal. See performance chart.

INTERNAL LEAKAGE: 5 cu.in./min [82 cc/m]

DEFINITION OF CRACK: evident at 0.06 GPM [0.25 LPM]

VALVE HOUSINGS: 2500 PSI [175 Bar] = Aluminum - Anodized.

5000 PSI [350 Bar] = Steel - Unplated.

OPERATING TEMPERATURE: -40° to +250° F. [-40° to +120° C.]

OPERATING MEDIA: All general purpose hydraulic fluids such as MIL-H-5606, SAE-#10, SAE-#20, etc.

INSTALLATION: No restriction.

FILTRATION: 25 microns or better.

SEAL KIT NUMBER: SKN-1022 for Buna "N".

SKV-1022 for Viton.

WEIGHT: 0.42 lbs [0,19 kg] cartridge only.

VALVE CAVITY: #C1020, See Page 0-012.0.

info.el@bucherhydraulics.com

www.bucherhydraulics.com/commoncavity

© 2015 by Bucher Hydraulics, Inc., 2545 Northwest Parkway, Elgin, Illinois 60124, USA

All rights reserved.

Data is provided for the purpose of product description only, and must not be construed as warranted characteristics in the legal sense. The information does not relieve users from the duty of conducting their own evaluations and tests. Because the products are subject to continual improvement, we reserve the right to amend the product specifications contained in this catalogue.