

PRESSURE COMPENSATED, NORMALLY CLOSED OR NORMALLY OPEN PROPORTIONAL, IN-LINE FLOW CONTROL VALVE.

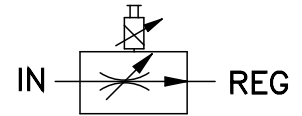

UL approved coil, IP68 and IP69K rated when used with waterproof connector.

LIMITED RANGE ADJUSTMENT (SCREW TYPE)

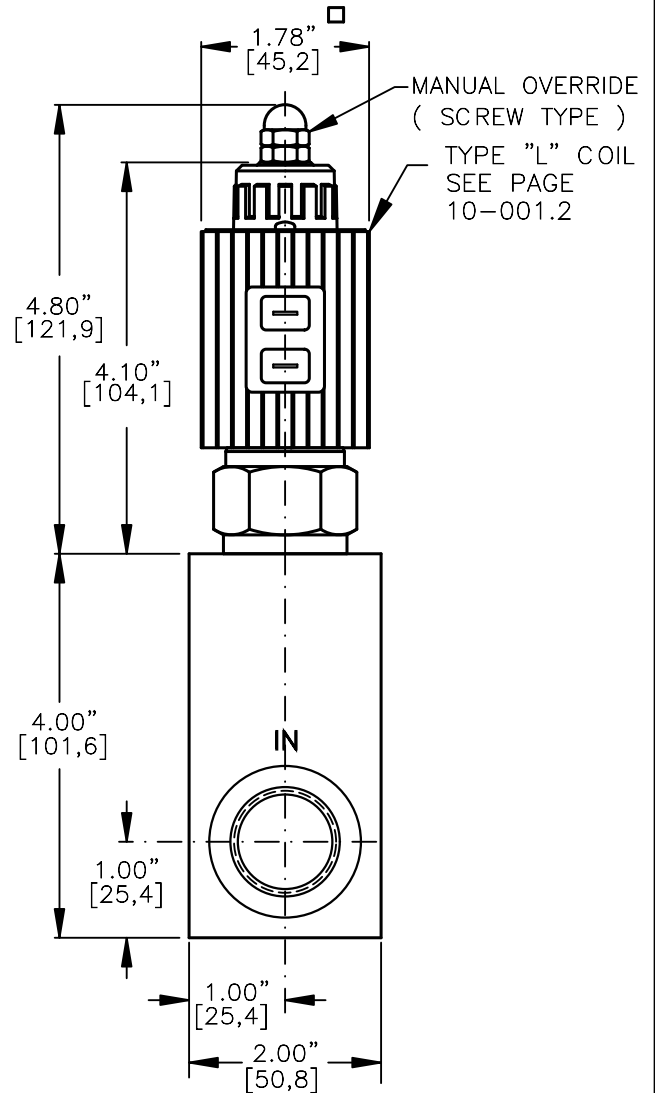
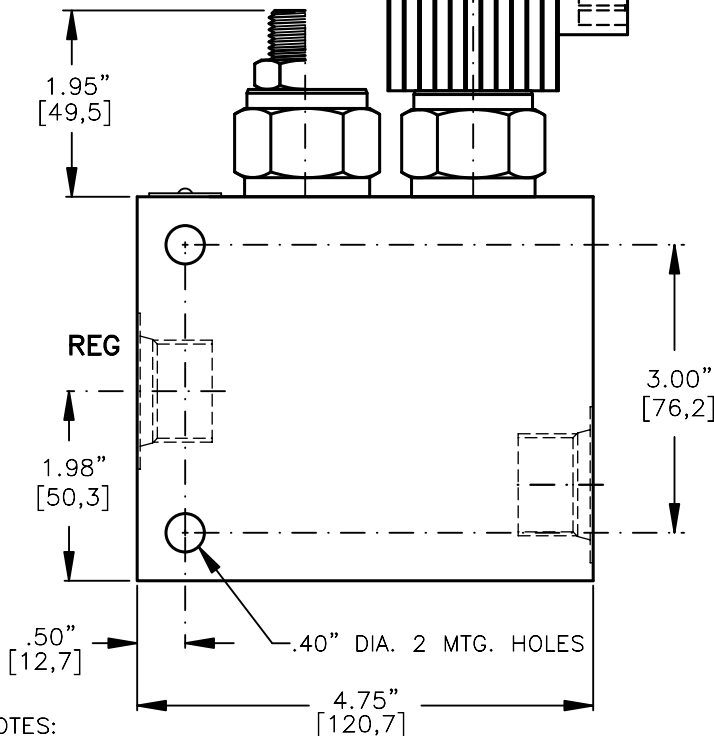

NOTES:
1. SOLENOIDS AVAILABLE WITH DIODES - CONSULT FACTORY.

PIFC-12-X-X-XX-X-X-X-XXX-XXX X

BASIC
SIZE
12=1.062"-12UNF

SEALS
N = BUNA "N"
V = VITON

STYLE
C = NORMALLY CLOSED
O = NORMALLY OPEN

REGULATED FLOW
06 = 0 TO 6.0 GPM
12 = 0 TO 12.0 GPM
18 = 0 TO 18.0 GPM
24 = 0 TO 24.0 GPM

TERMINALS
L = 18GA. 24" LEADS
T = SPADE TERM.
B = BOLT TERM.
G = DIN43650
W = WEATHER-PACK
D = DEUTSCH-DT04-2P
M = METRI-PACK CONN.

VOLTAGE AMPS
12D = 12 VDC 3.00
24D = 24 VDC 1.50

ADJUSTMENT OPTIONS
O-F-100 = NONE
M-F-100 = MANUAL OVERRIDE
O-S-160 = LIMITED RANGE ADJ
M-S-160 = BOTH MO/LTD ADJ

PORTS
12TX = SAE - #12
"A" = ALUM. HOUSING
"S" = STEEL HOUSING

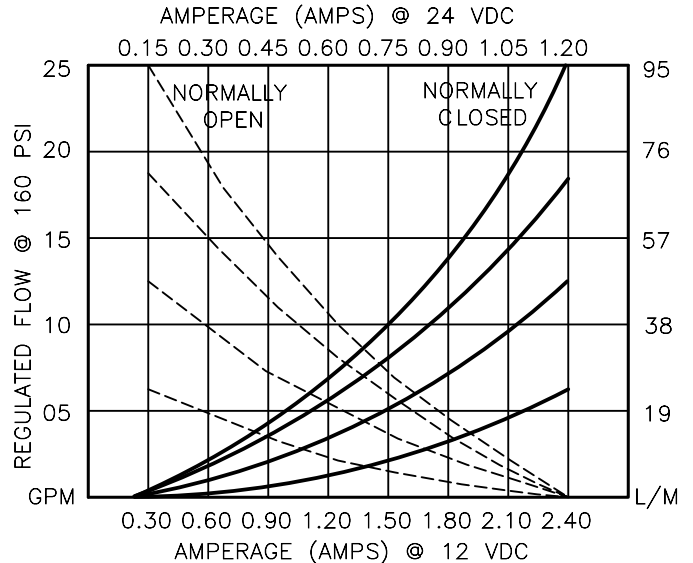

PRESSURE COMPENSATED, PROPORTIONAL, IN-LINE, FLOW CONTROL VALVE.**DESCRIPTION**

This valve is an electro-hydraulic, proportional, in-line (Restrictive) type, pressure compensated, hydraulic flow control. Regulated flow Normally Closed 0 to 24.0 GPM, [0 to 91,2 L/M] max. Normally Open 24.0 to 0 GPM [91,2 to 0 L/M] is proportional to the current input, regardless of load or system pressure.

OPERATIONS

This unit is a direct acting (NO PILOT FLOW), electro-hydraulic, proportional, pressure compensated, flow control valve. When the coil is energized the armature moves the metering orifice open or close against a precision bias spring varying the flow. A pressure compensator spool (HYDROSTAT) modulates the flow at 160 PSI/11,0 Bar delta "P" providing the valve with a constant regulated flow regardless of load or system pressure. When current is increased or decreased to the coil; the flow will increase or decrease proportionally.

IN THE EVENT OF POWER FAILURE THE VALVE WILL CLOSE OR OPEN RESPECTIVELY.

FEATURES AND BENEFITS

Continuous-duty, very low heat rise & waterproof solenoid coil.
Interchangeable solenoid coils & terminations options available.
Hardened precision fitted spool & sleeve provides reliable, long life.
Very efficient wet – armature solenoid core tube construction.
All external carbon steel parts are plated for longer life against the elements.
All valves are 100% functionally tested.

PRESSURE COMPENSATED, PROPORTIONAL, IN-LINE, FLOW CONTROL VALVE.

SPECIFICATIONS

OPERATING PRESSURE: 5,000 PSI [350 Bar]

PROOF PRESSURE: 10,000 PSI [700 Bar]

REGULATED FLOW: 24.0 GPM [90,7 L/M] Max. See performance chart.

INTERNAL LEAKAGE: 30 cu.in/min [495 cc/m] @ 5,000 PSI [350 Bar]

VALVE HOUSINGS: 2500 PSI [175 Bar] = Aluminum – Anodized.

5000 PSI [350 Bar] = Steel – Unplated.

OPERATING TEMPERATURE: -40° to +250° F. [-40° to +120° C.]

OPERATING MEDIA: All general purpose hydraulic fluids such as
MIL-H-5606, SAE-#10, SAE-#20, etc.

RESPONSE: The most efficient method to control this valve is with
current control and a 50 Hz dither.

POWER REQUIREMENTS: 12 VDC, Operating current 0.4 to 2.4 AMPS.

24 VDC, Operating current 0.2 to 1.2 AMPS.

SEAL KIT: Buna "N": SKN-1222, SKN-1232

VITON: SKV-1222, SKV-1232

INSTALLATION: No restrictions.

WEIGHT: 5.52 lbs [2,51 kg]. aluminum body.

15.60 lbs [7,10 kg]. steel body.

info.el@bucherhydraulics.com

www.bucherhydraulics.com/commoncavity

© 2015 by Bucher Hydraulics, Inc., 2545 Northwest Parkway, Elgin, Illinois 60124, USA

All rights reserved.

The technical information in this catalog, may contain calculated figures (for reference only) and not actual performance data for this product.

Data is provided for the purpose of product description only, and must not be construed as warranted characteristics in the legal sense.

The information does not relieve users from the duty of conducting their own evaluations and tests. Because the products are subject to continual improvement, we reserve the right to amend the product specifications contained in this catalogue.