

PILOT OPERATED CHECK VALVE POPPET TYPE,
PILOT TO CLOSE, PILOT RATIO.

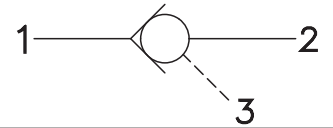

TORQUE:

Steel = 55/60 Ft-Lb. [74/81 Nm]
Aluminum = 35/40 Ft-Lb. [47/54 Nm]

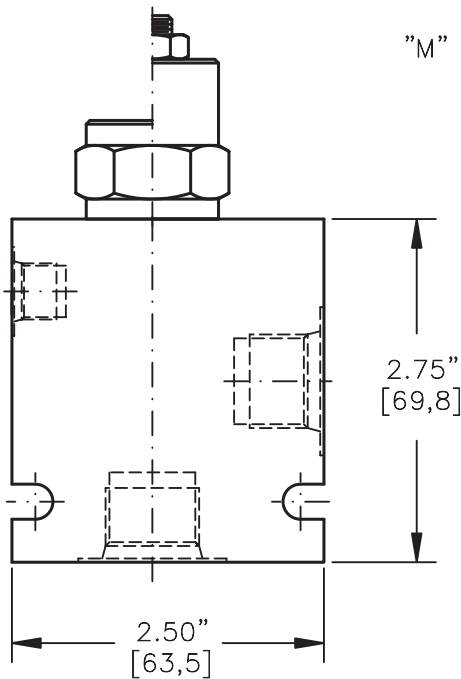
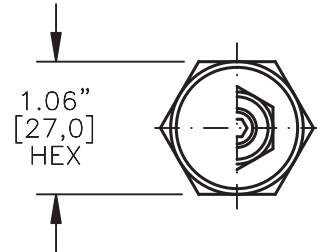

"M" MANUAL LOAD RELEASE
1/2" [12,7] HEX

"F" FIXED

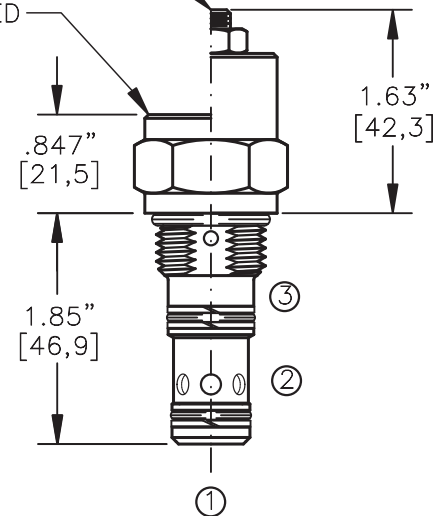

NOTE: FOR ALUMINUM OR STEEL VALVE HOUSING CONFIGURATIONS SEE PAGE 0-022.1.

PTCC-10-X-X-X-X

BASIC

SIZE

10 = 7/8"-14 UNF

SEALS

N = BUNA "N"

V = VITON

ADJUSTMENT

F = FIXED

M = MANUAL RELEASE

PILOT RATIO

2 = 2 TO 1

3 = 3 TO 1

PORTS

0 = CARTRIDGE ONLY

06TX = SAE - #6

08TX = SAE - #8

02BX = 1/4" BSPP

03BX = 3/8" BSPP

"A" - ALUM. HOUSING

"S" - STEEL HOUSING

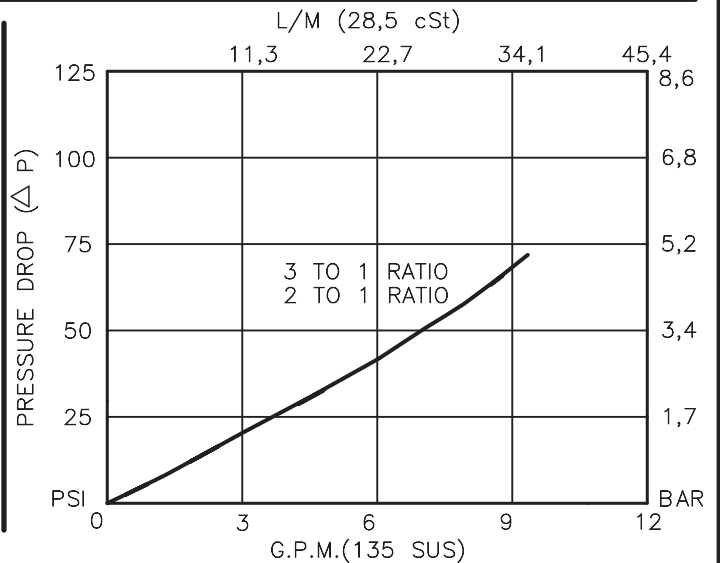

PILOT OPERATED CHECK VALVE

POPPET TYPE, PILOT TO CLOSE, PILOT RATIO.

DESCRIPTION

This unit is a SCREW-IN cartridge type, guided poppet, hydraulic pilot operated check valve, for use as a blocking or load holding device for high pressure applications.

OPERATIONS

This valve allows free flow from port 1 to port 2 and blocks flow from port 2 to port 1 for holding a load. Flow will not be allowed from port 2 to port 1 when pressure is applied to port 3. This pilot operated check valve has a 3 to 1 or 2 to 1 pilot ratio, meaning that port 3 requires at least one-third or half of the load pressure held at port 2 to close the valve.

FEATURES AND BENEFITS

A low friction seal on pilot piston is standard.
 A separate heavy spring assures fast return of the pilot piston for a very quick, reliable and positive valve re-open.
 Optional screw type manual load release is available.
 All external carbon steel parts are plated for longer life against the elements.
 All cartridge valves are 100% functionally tested.
 Industry common cavity.

SPECIFICATIONS

OPERATING PRESSURE: 5,000 PSI [350 Bar]
 PROOF PRESSURE: 10,000 PSI [700 Bar]
 FLOW: 10.0 GPM [38 l/m] nominal. See performance chart.
 PILOT RATIO: 3 TO 1 OR 2 TO 1
 INTERNAL LEAKAGE: 5 drops per minute maximum @ 5,000 PSI [350 Bar]
 VALVE HOUSINGS: 2500 PSI [175 Bar] = Aluminum – Anodized.
 5000 PSI [350 Bar] = Steel – Unplated.
 OPERATING TEMPERATURE: -40° to +250° F. [-40° to +120° C.]
 OPERATING MEDIA: All general purpose hydraulic fluids such as
 MIL-H-5606, SAE-#10, SAE-#20, etc.
 INSTALLATION: No restrictions.
 SEAL KIT: SKN-1028 Buna "N"
 SKV-1028 Viton
 WEIGHT: .32 lb [.15 kg] cartridge only.
 VALVE CAVITY: #C1025, See Page 0-022.0.

info.el@bucherhydraulics.com

www.bucherhydraulics.com/commoncavity

© 2015 by Bucher Hydraulics, Inc., 2545 Northwest Parkway, Elgin, Illinois 60124, USA

All rights reserved.

Data is provided for the purpose of product description only, and must not be construed as warranted characteristics in the legal sense. The information does not relieve users from the duty of conducting their own evaluations and tests. Because the products are subject to continual improvement, we reserve the right to amend the product specifications contained in this catalogue.