

General information

Cavity

Type series: Cavity C0825

Dimensions and sectional view

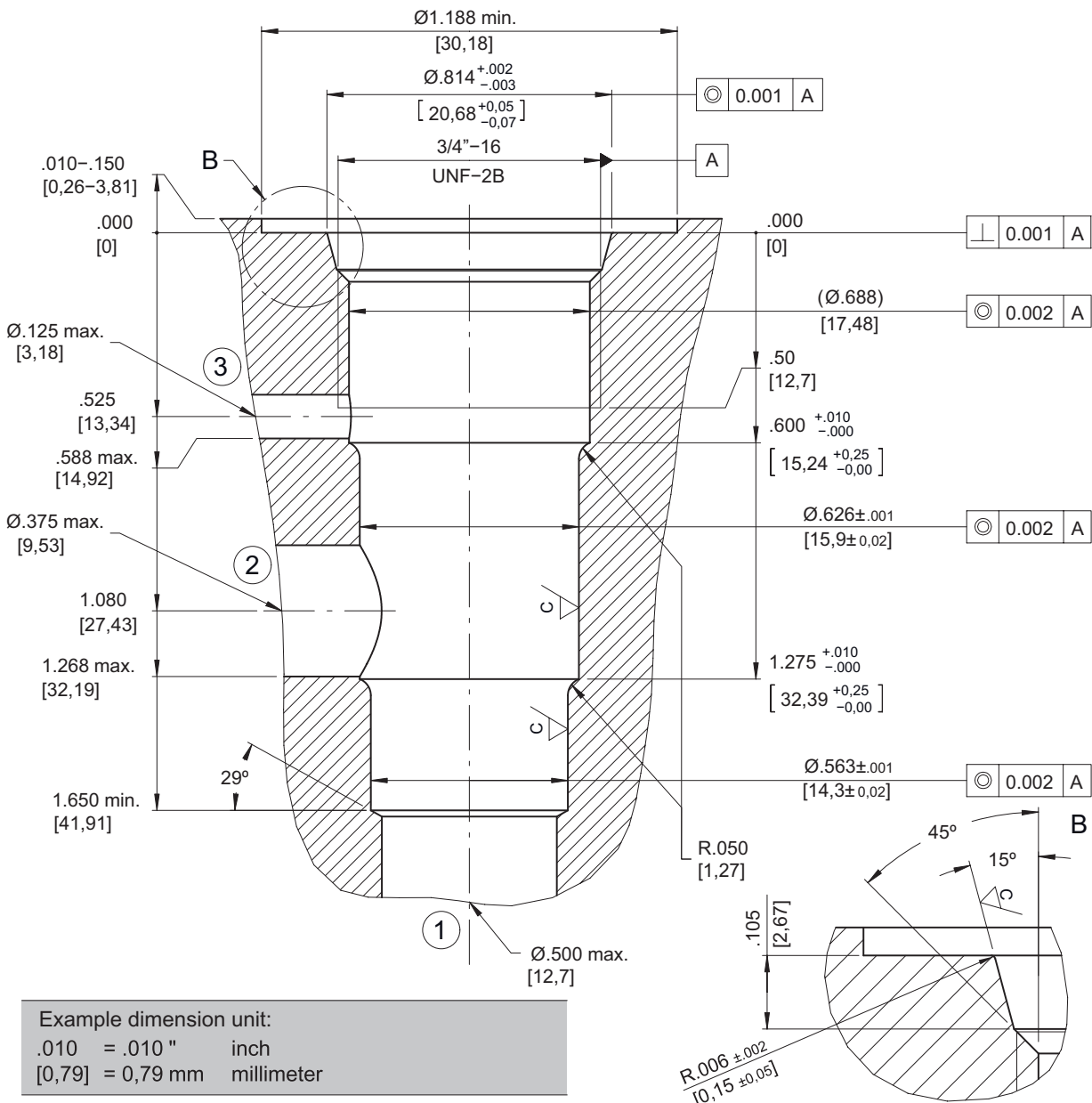

Example dimension unit:
 $.010 = .010''$ inch
 $[0,79] = 0,79$ mm millimeter

Dimension Tolerances

Unless otherwise specified

0.000	$\pm .005''$
0.00	$\pm .010''$
Angles	$\pm 1/2^\circ$

Surface roughness

	C	D
Ra	45 μ m (1.15 μ m)	125 μ m (3.2 μ m)
	Unless otherwise specified	

Installation information

**ATTENTION!**

You must maintain the specified positional and diametral tolerances. To ensure trouble-free operation of the screw-in cartridges, we strongly recommend that pilot drilling, boring, reaming and cavity thread-cutting are always performed in one setup.

**NOTE!**

The cavity type C0825 complies with the standard according to: ISO 17209: 3/4-02-0-13 and NFPA/T3.5.50: 0.750-02-0-09.

**NOTE!**

We offer form tool sets for sale or hire. For further information, see data sheet 520-P-000050.