

# Pressure valve Reducing function

$Q_{\max} = 3.75 \text{ gpm}$ ,  $p_{\max} = 1000 \text{ psi}$

Direct acting, spool type, proportional solenoid

Type series: DDRCZ-7...

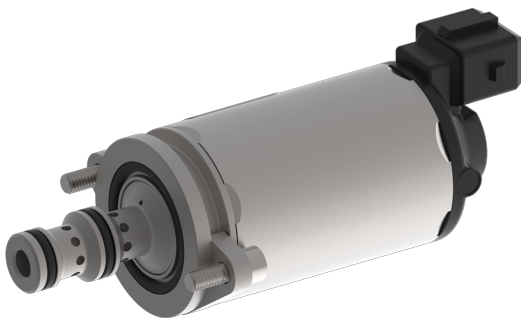

- Slip-in cartridge valve for cavity AGA
- All external parts with zinc-nickel plating according to DIN EN ISO 19598
- Installation in threaded port body type GAAA
- Excellent stability over the whole pressure and flow range
- Various plug-connector systems and voltages are available
- Operated by a proportional solenoid

## Symbol

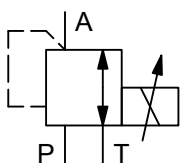

DDRCZ-7...

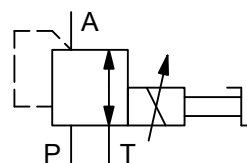

DDRCZ-7...S619

## Description

Series DDRCZ-70... proportional 3-way pressure-reducing valves are direct acting push-in valves with a compact solenoid system and are available in sizes 2...5. They reduce the outlet pressure in A as a function of the control current signal and independently of the inlet pressure in P. In the initial position (solenoid de-energized) the inlet of the 3-way pressure-reducing valve is shut off and the outlet is connected to tank (port A to T). In control mode, the connection P to A opens until the pressure in port A reaches the preset level. If the pressure rises above the preset level, the control spool opens the A to T connection until balance is attained. Five pressure ranges are available in order to obtain

precise pressure settings over the whole of the required pressure range. The maximum operating pressure depends on the particular pressure range. All external parts are zinc-nickel plated and are thus suitable for use in the harshest operating environments. These valves are predominantly used for reducing a system pressure in mobile and industrial applications. They are suitable for controlling larger directional valves, where they can be incorporated in the valve body or directly in the end covers, for example, and for controlling pumps and motors. The advantages are the small space requirement, 360° rotatability at installation, and easy installation of the plug-in cartridge thanks to the mounting clip.

The compact solenoid system also offers an ideal price/performance ratio, which is vital for reducing operating

costs and capital expenditures. For self-assembly, please refer to the section related data sheets.

## Technical data

General characteristics	Description, value, unit
Function group	pressure valve
Function	reducing function
Design	slip-in cartridge valve
Controls	proportional solenoid
Characteristic	direct acting, spool type
MTTFd value	150 years
Construction size	NG 2
Mounting attitude	unrestricted (preferably vertical, coil down)
Weight	0.99 lb
Cavity acc. factory standard	AGA
Tightening torque steel	1.3 ft·lb
Tightening torque aluminium	1.3 ft·lb
Tightening torque tolerance	± 10 %
Minimum ambient temperature	- 22 °F
Maximum ambient temperature	+ 122 °F
Surface protection	all external parts with zinc-nickel plating according to DIN EN ISO 19598
Sealing material	see ordering code
Seal kit order number	NBR: DS-324-N / FKM: DS-324-V

Hydraulic characteristics	Description, value, unit
Maximum operating pressure	1000 psi
Maximum flow rate	3.75 gpm
Flow direction	see symbol
Hydraulic fluid	HL and HLP mineral oil according to DIN 51 524; other fluids on request!
Minimum fluid temperature	- 22 °F
Maximum fluid temperature	+ 158 °F
Viscosity range	15 ... 380 mm <sup>2</sup> /s (cSt)
Recommended viscosity range	20 ... 130 mm <sup>2</sup> /s (cSt)
Minimum fluid cleanliness (cleanliness class according to ISO 4406:1999)	class 18/16/13

**Electric characteristics**

Supply voltage DC	12/24 V DC
Control current	12 V = 0...1500 mA / 24 V = 0...800 mA
Nominal power consumption	max. 18 W
Relative duty cycle	100 %
Coil resistance R	cold value at 68 °F = 12 V = 4.8 Ω / 24 V = 17.6 Ω cold value at -13 °F = 12 V = 4.0 Ω / 24 V = 14.5 Ω max. warm value = 12 V = 8.0 Ω / 24 V = 28.0 Ω
Recommended PWM frequency	200 Hz
Response sensitivity with PWM	< 1 % I <sub>N</sub>
Reproducibility with PWM	< 2 % p <sub>N</sub>
Hysteresis with PWM	2...4 % I <sub>N</sub>
Reversal error with PWM	2...4 % I <sub>N</sub>
Electrical connection coil	several connection types available, see ordering code
Protection class solenoid coil to ISO 20 653 / EN 60 529	IP 65 / IP 67 / IP 69K, see "Ordering code" (with appropriate mating connector and proper fitting and sealing)

**Description, value, unit**

12/24 V DC
12 V = 0...1500 mA / 24 V = 0...800 mA
max. 18 W
100 %
cold value at 68 °F = 12 V = 4.8 Ω / 24 V = 17.6 Ω cold value at -13 °F = 12 V = 4.0 Ω / 24 V = 14.5 Ω max. warm value = 12 V = 8.0 Ω / 24 V = 28.0 Ω
200 Hz
< 1 % I <sub>N</sub>
< 2 % p <sub>N</sub>
2...4 % I <sub>N</sub>
2...4 % I <sub>N</sub>
several connection types available, see ordering code
IP 65 / IP 67 / IP 69K, see "Ordering code" (with appropriate mating connector and proper fitting and sealing)

**Performance graphs**

measured with oil viscosity 33.0 mm<sup>2</sup>/s (cSt)

p = f (I) Pressure adjustment

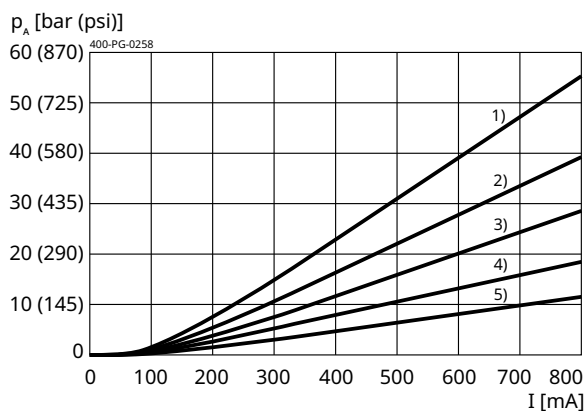

- 1) = p<sub>N</sub> 55 bar (800 psi)
- 2) = p<sub>N</sub> 40 bar (580 psi)
- 3) = p<sub>N</sub> 30 bar (435 psi)
- 4) = p<sub>N</sub> 20 bar (290 psi)
- 5) = p<sub>N</sub> 11 bar (160 psi)

p = f (I) Pressure adjustment

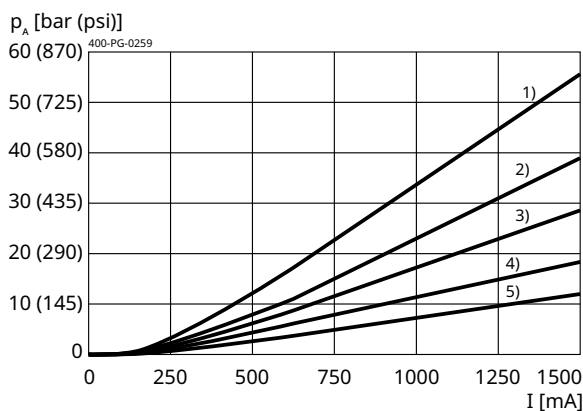

- 1) = p<sub>N</sub> 55 bar (800 psi)
- 2) = p<sub>N</sub> 40 bar (580 psi)
- 3) = p<sub>N</sub> 30 bar (435 psi)
- 4) = p<sub>N</sub> 20 bar (290 psi)
- 5) = p<sub>N</sub> 11 bar (160 psi)

$p = f(Q)$  Pressure-flow rate

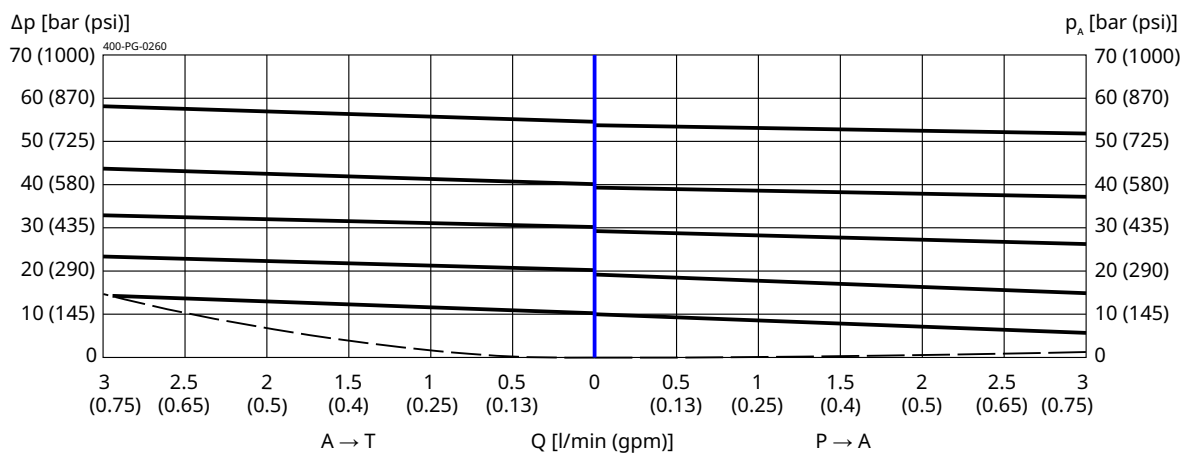

$p = f(Q)$  Pressure-flow rate

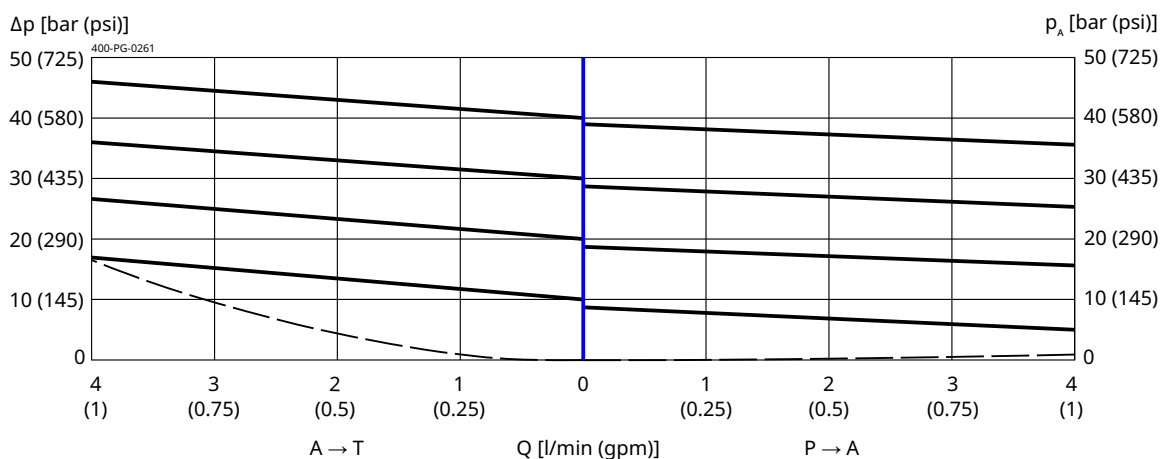

$p = f(Q)$  Pressure-flow rate

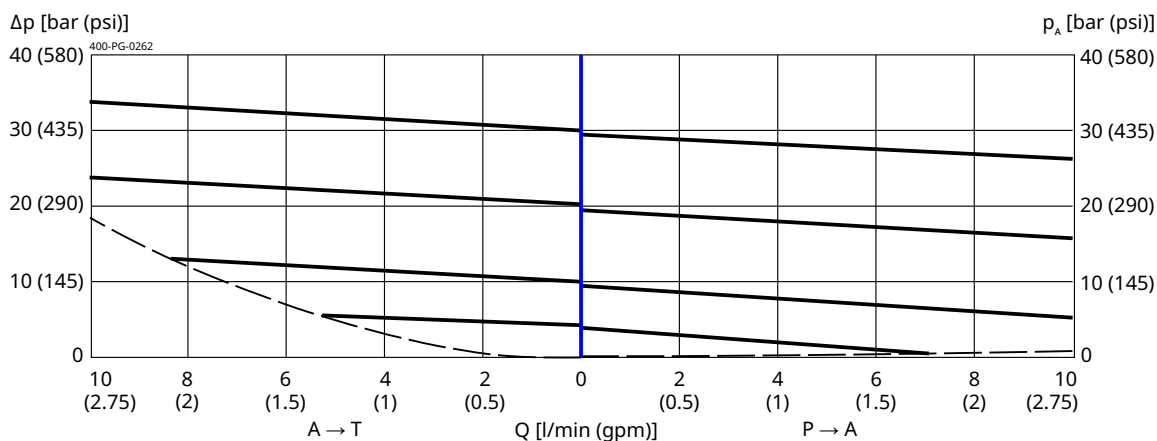

$p = f(Q)$  Pressure-flow rate

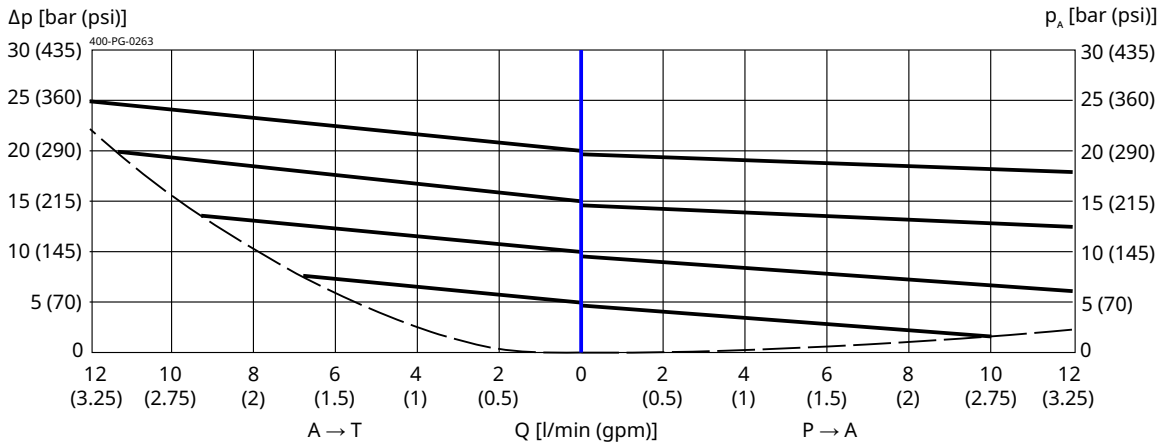

$p = f(Q)$  Pressure-flow rate

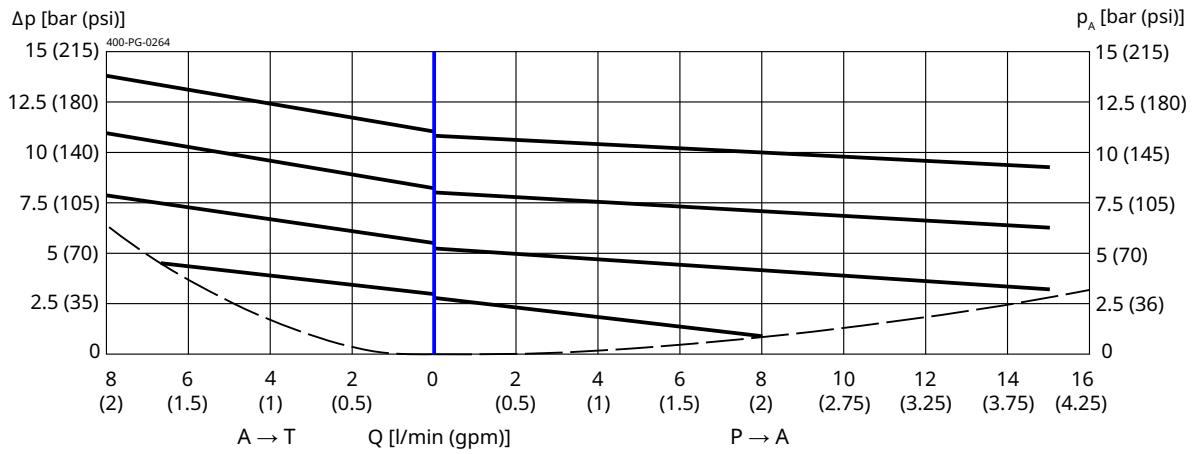

## Installation

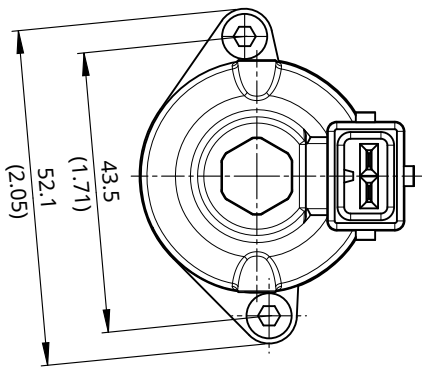

Beispiel für die Masseinheit:  
Example for the dimensional units:  
0.79 = 0.79 mm millimeter  
(.031) = 0.031" inch

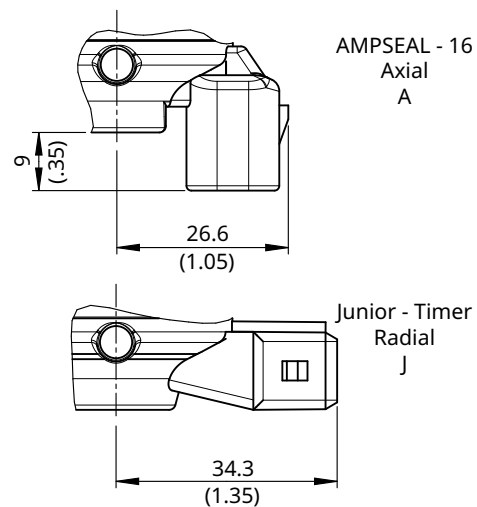
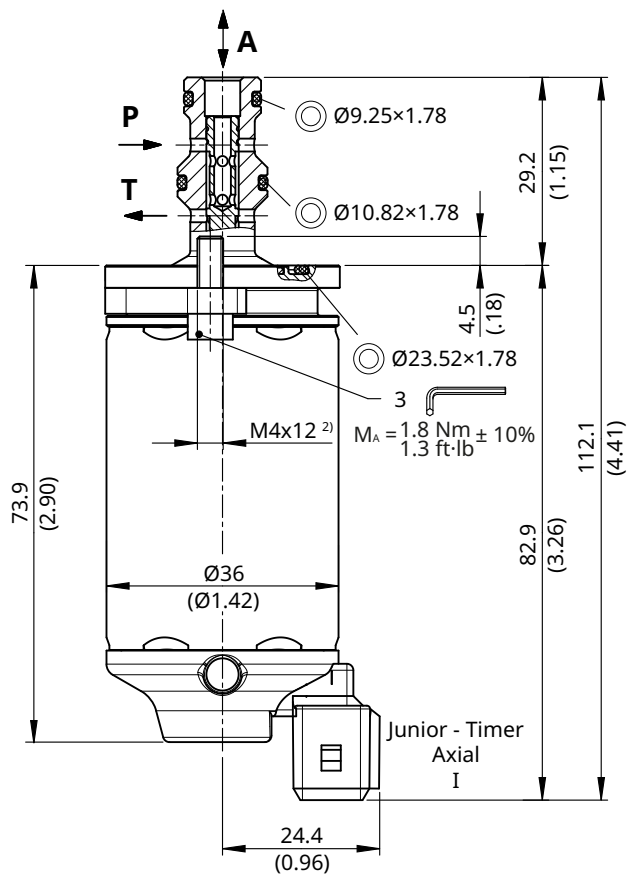

**i NOTE!**  
1) When fitting the screw-in cartridge valve, use the specified tightening torque. The value can be found in the chapter "Technical data".

**i IMPORTANT!**  
When fitting the cartridges, note the mounting attitude (preferably vertical, with coil down → automatic air bleed) and use the specified tightening torque. No adjustments are necessary, since the cartridges are set in the factory.

**i NOTE!**  
The seals are not available individually. The seal kit order number can be found in the chapter "Technical data".

**! ATTENTION!**  
Only qualified personnel with mechanical skills may carry out any maintenance work. Generally, the only work that should ever be undertaken is to check, and possibly replace, the seals. When changing seals, oil or grease the new seals thoroughly before fitting them.

### Auxiliary manual adjustment

As an option, series DDRCZ... proportional 3-way pressure-reducing valves can be provided with an auxiliary manual adjustment, type S619. In the event of a power

failure, for example, it can be used to set the required pressure mechanically.

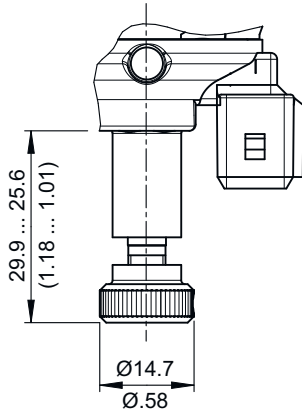

## Ordering code

Ex. 

DDR	C	Z	-	7	011	-	2	-	3	24	D	-	S619
-----	---	---	---	---	-----	---	---	---	---	----	---	---	------

DDR	=	pressure-reducing cartridge, direct acting	
C	=	compact solenoid (proportional)	
A ... Q	=	standard model according to valid data sheet	
Y ... R	=	special model (on request)	
7	=	3-way pressure-reducing	
011	=	pressure range ... 11 bar	
020	=	pressure range ... 20 bar	
030	=	pressure range ... 30 bar	
040	=	pressure range ... 40 bar	
055	=	pressure range ... 55 bar	
2	=	nominal size 2 for pressure range 055	
2	=	nominal size 2 for pressure range 040	
3	=	nominal size 3 for pressure range 030	
4	=	nominal size 4 for pressure range 020	
5	=	nominal size 5 for pressure range 011	
(blank)	=	NBR (nitril-butadien-rubber / BUNA) seals <b>(standard)</b>	
V	=	FKM (fluorocarbon rubber / VITON) seals (special seals on request)	
1...9	=	technical design no. (omit by ordering)	
...	=	voltage e.g. 24 (24 V)	
D	=	current DC	
(blank)	=	DIN EN 175301-803 connection 3-pole 2 P+E <b>(standard)</b>	(IP 65) with mating plug
J	=	Junior Timer plug connection 2-pole radial	(IP 65)
I	=	Junior Timer plug connection 2-pole axial	(IP 65)
D	=	Deutsch plug connection DT04-2P 2-pole 45°	(IP 67/69K) } mating plug not supplied
A	=	AMPSEAL plug connection 2-pole axial	(IP 67/69K)
F	=	flying leads (20 inch / 500 mm) other plug-variants, please consult BUCHER.	(IP 65)
S619	=	as option: auxiliary manual adjustment (mechanical pressure setting)	



### IMPORTANT!

Not every combination of voltage values, current type and plug connections available.

## Related data sheets

Reference	Description
<a href="#">400-P-040011</a>	form tools
<a href="#">400-P-010101</a>	MTTFd Values for Hydraulic Valves
<a href="#">400-P-040142</a>	cavity AGA
<a href="#">400-P-712101</a>	threaded port body GAAA

[info.ch@bucherhydraulics.com](mailto:info.ch@bucherhydraulics.com)

[www.bucherhydraulics.com](http://www.bucherhydraulics.com)

© 2026 by Bucher Hydraulics AG Frutigen, 3714 Frutigen, Switzerland

All rights reserved.

Data is provided for the purpose of product description only, and must not be construed as warranted characteristics in the legal sense. The information does not relieve users from the duty of conducting their own evaluations and tests. Because the products are subject to continual improvement, we reserve the right to amend the product specifications contained in this catalogue.