

## Prop. 3-Way Pressure-Reducing Valve, ISO Size 03

$Q_{\max} = 60 \text{ l/min}$ ,  $p_{\max} = 350 \text{ bar}$

Sandwich design, electrically operated, seated pilot stage

Series SDRVSA-7...

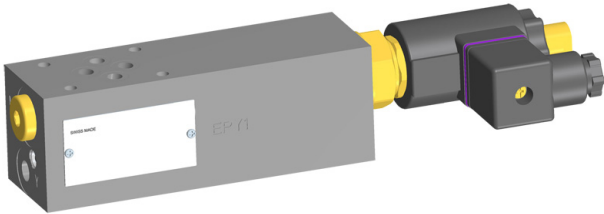

- With cartridge valve, type DRVSA-7P...-10...
- Interface to ISO 4401-03-02
- Full-flow secondary pressure relief
- Function in the P or A line
- External pilot-oil drain
- 4 pressure ranges available
- With pressure-gauge port
- Excellent stability over the whole pressure and flow range
- External cartridge parts are zinc plated and chromited (CrVI-free)
- The slip-on coil can be rotated, and it can be replaced without opening the hydraulic envelope
- Various plug-connector systems and voltages are available

### 1 Description

Series SDRVSA-7...-6... sandwich valves are high performance, electrically operated proportional 3-way pressure-reducing valves with a size 03 interface to ISO 4401-03-02. The main components of the valves are a sandwich body (stack-mounting body) and the screw-in cartridge (type DRVSA-7P...-10...). The pressure-reducing cartridges have a seated pilot stage, and the main stage is designed on the sliding-spool principle. Two models are available, one with the function in P and the other with the function A and an integral bypass check valve. Both models are provided with external pilot-oil drain through Y. These valves reduce the pressure in the secondary side of P or A (for flow IN) respectively to a level that is proportional to the solenoid current, which depends on the demand signal to the electronics. These 3-way pressure-reducing cartridges function as

full-flow pressure-relief valves from port P → T or A → T respectively as soon as the reduced pressure rises above the valve pressure setting. Thanks to the external pilot-oil drain, the reduced pressure is unaffected by any pressure fluctuations. A pressure-gauge port M (G1/4") is also provided in the secondary circuit. These sandwich valves are used to reduce the system pressure in mobile and industrial applications. All external parts of the cartridge are zinc-nickel plated according to DIN EN ISO 19 598 and are thus suitable for use in the harshest operating environments. The slip-on coils can be replaced without opening the hydraulic envelope and can be positioned at any angle through 360°. The sandwich body is sealed at its manifold side (the connections side) by means of O-rings fitted in counterbores.

### 2 Technical data

General characteristics	Description, value, unit
Designation	proportional 3-way pressure-reducing valve
Design	sandwich design, electrically operated, seated pilot stage
Mounting method	4 x Ø 5.4 holes for M5 cap screws
Size	size 03 interface to ISO 4401-03-02 / DIN 24 340 A6
Weight	2.8...3.2 kg
Mounting attitude	unrestricted
Ambient temperature range	-25 °C ... +50 °C
Surface corrosion protection	without

Hydraulic characteristics	Description, value, unit
Maximum operating pressure - ports P, A, B, T - port Y	350 bar 250 bar <sup>1)</sup>
Flow range	...60 l/min
Nominal pressure ranges	...100 bar, ...160 bar, ...250 bar, ...350 bar
Pilot-oil consumption	0.3 ... 0.5 l/min
Flow direction	see symbols
Hydraulic fluid	HL and HLP mineral oil to DIN 51 524; for other fluids, please contact BUCHER
Hydraulic fluid temperature range	-25 °C ... +70 °C
Viscosity range	15...380 mm <sup>2</sup> /s (cSt), recommended 20...130 mm <sup>2</sup> /s (cSt)
Minimum fluid cleanliness Cleanliness class to ISO 4406 : 1999	class 18/16/13



### ATTENTION!

<sup>1)</sup> To prevent any pressure surges, port Y must be routed to tank with the least possible back-pressure.

Electrical characteristics	Description, value, unit
Supply voltage	12 V DC, 24 V DC
Supply voltage tolerance	± 10 %
Control current	12 V = 0...1400 mA, 24 V = 0...750 mA
Power consumption at max. control current	max. 19 W
Coil resistance R - cold value at 20 °C - max. warm value	12 V = 5.8 Ω / 24 V = 21 Ω 12 V = 8.6 Ω / 24 V = 32 Ω
Recommended PWM frequency (dither)	200 Hz
Hysteresis with PWM	2...4 % I <sub>N</sub>
Reversal error with PWM	1...3 % I <sub>N</sub>
Sensitivity with PWM	≤ 1 % I <sub>N</sub>
Reproducibility with PWM	< 2 % p <sub>N</sub>
Switching time	<i>Pressure-reducing function:</i> 20 ... 29 ms (Solenoid ON) 12 ... 26 ms (Solenoid OFF)  <i>Pressure-relief function:</i> 24 ... 62 ms (Solenoid ON) 15 ... 45 ms (Solenoid OFF)  The switching times are strongly influenced by flow rate, pressure, viscosity and the dwell period under pressure.
Relative duty cycle	100 %
Protection class to ISO 20 653 / EN 60 529	IP 65 / IP 67 / IP 69K, see "Ordering code" (with appropriate mating connector and proper fitting and sealing)
Electrical connection	DIN EN 175301-803, 3-pin 2 P+E (standard) for other connectors, see "Ordering code"

### 3 Symbol

Function in P,  
with external pilot-oil drain through Y

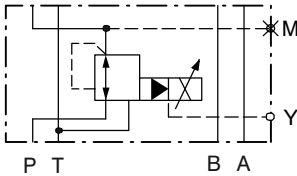

SDRVSA-7...-P-1...

Function in A (for flow IN),  
with external pilot-oil drain through Y

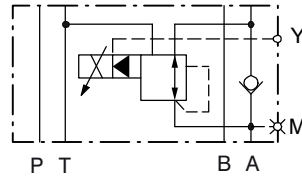

SDRVSA-7...-AZR-1...

### 4 Performance graphs



**IMPORTANT!**

Detailed performance data and other hydraulic characteristics can be found in the data sheet for the prop. 3-way pressure-reducing cartridge that is fitted (data sheet ref. no. 400-P-591101-E).



**ATTENTION!**

The performance figures in the data sheet for the cartridge valve refer just to the cartridge itself. Take into account the additional pressure drop in the body into which it is fitted.

### 5 Dimensions & sectional view

#### 5.1 Function in P

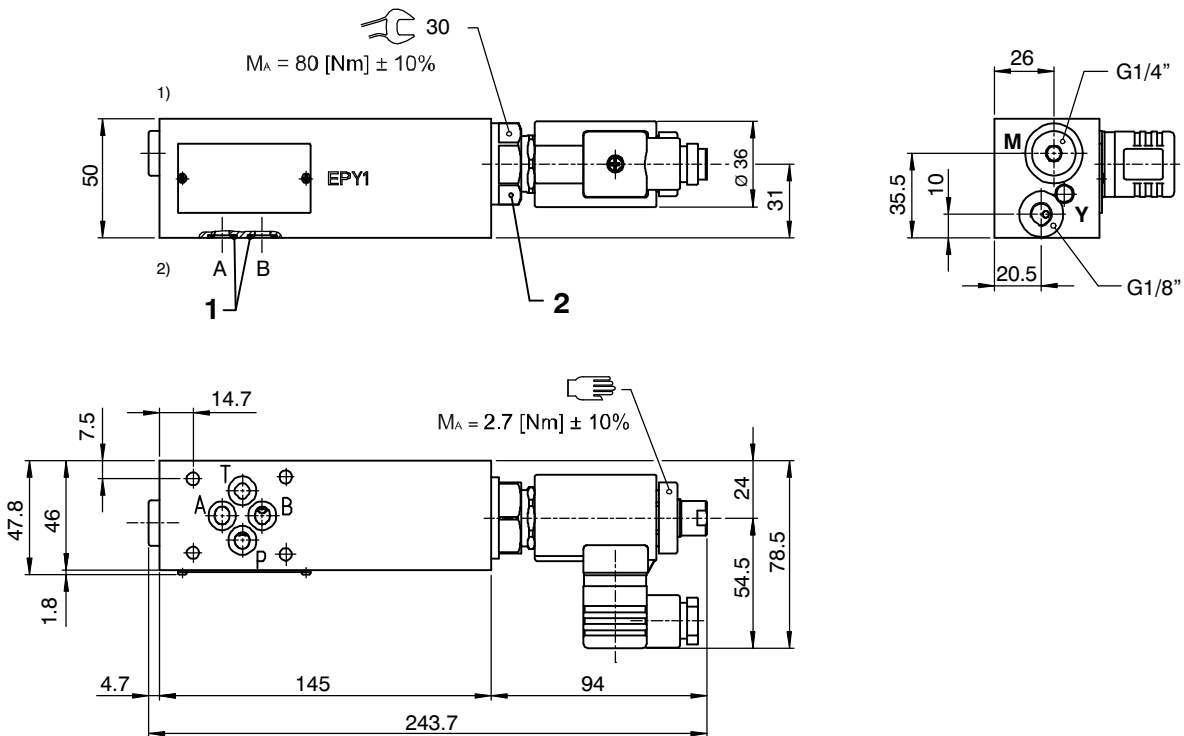

- 1) Valve side
- 2) Connections side (manifold side)
- Y Pilot-oil drain (to tank without back-pressure)
- M Pressure-gauge port (with G 1/4" threaded plug, ED VSTI)

## 5.2 Function in A (for flow IN), with bypass check valve

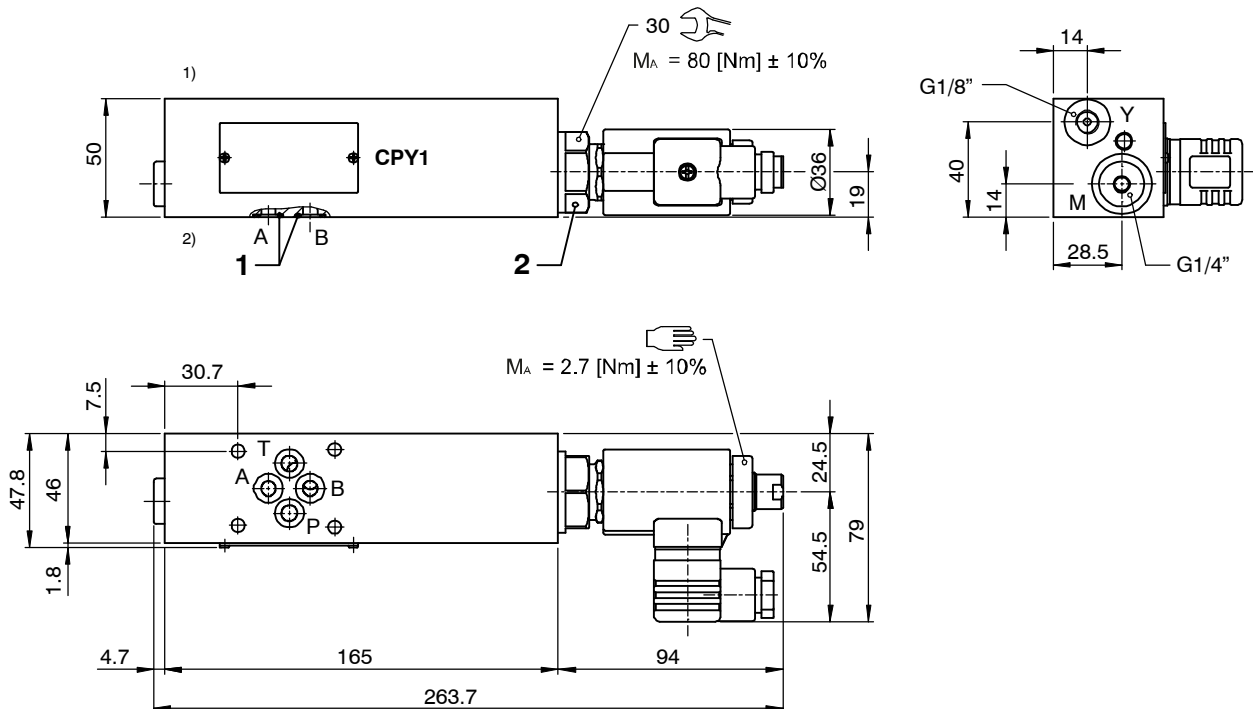

- 1) Valve side
- 2) Connections side (manifold side)
- Y Pilot-oil drain (to tank without back-pressure)
- M Pressure-gauge port (with G 1/4" threaded plug, ED VSTI)

## 6 Installation information



### IMPORTANT!

When installing the valve, make sure that the mating face (the manifold interface) aligns with the valve interface. Do not confuse the sandwich valve's manifold side and directional-valve side. No adjustments are necessary, since the cartridges are set in the factory.



### ATTENTION!

Only qualified personnel with mechanical skills may carry out any maintenance work. Generally, the only work that should ever be undertaken is to check, and possibly replace, the seals. When changing seals, oil or grease the new seals thoroughly before fitting them.



### ATTENTION!

To achieve the proportional 3-way pressure-reducing cartridge's maximum performance rating, fit the solenoid coil as shown (with the plug pins at the right). Use the specified tightening torque when fitting the cartridge.

### Seal kit NBR no. DS-396-N <sup>3)</sup>

Item	Qty.	Description
1	4	O-ring no. 012 $\varnothing$ 9,25 x 1,78 N90
2	1	NBR seal kit no. DS-394-N for pressure-reducing cartridge DRVSA-7P...



### IMPORTANT!

<sup>3)</sup> Seal kit with FKM (Viton) seals, no. DS-396-V

## 7 Ordering code

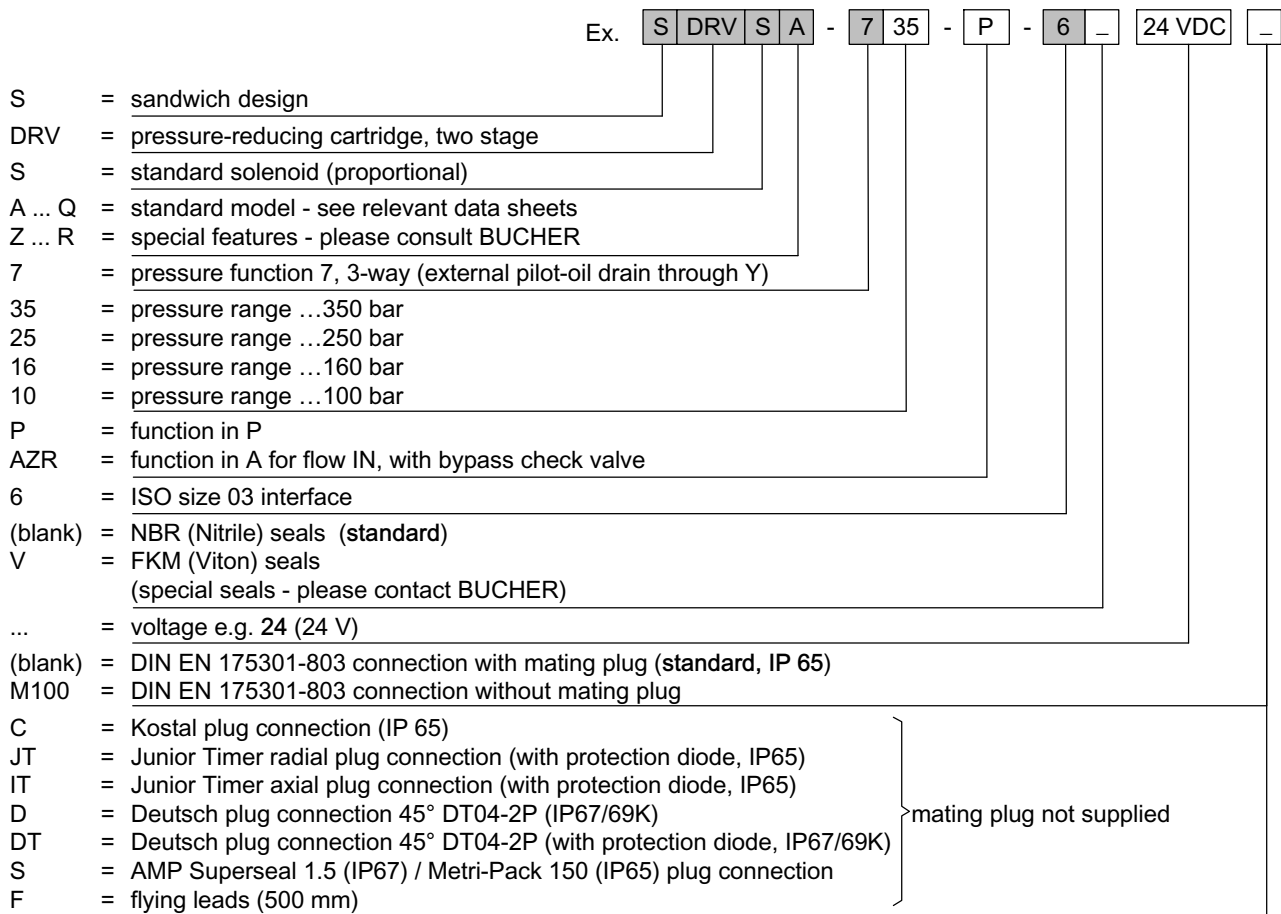

## 8 Related data sheets

Reference	(Old no.)	Description
400-P-030501	(i-31)	Size 03 interface to ISO 4401-03-02
400-P-120110	(W-2.141)	Coils for screw-in cartridge valves
400-P-591101		Prop. 3-way pressure-reducing valve, size 10, series DRVSA-7P...-10...
400-P-510101		Amplifier unit for proportional valves (1-channel) PBS - 3A

info.ch@bucherhydraulics.com

www.bucherhydraulics.com

© 2021 by Bucher Hydraulics AG Frutigen, CH-3714 Frutigen

All rights reserved.

Data is provided for the purpose of product description only, and must not be construed as warranted characteristics in the legal sense. The information does not relieve users from the duty of conducting their own evaluations and tests. Because the products are subject to continual improvement, we reserve the right to amend the product specifications contained in this catalogue.

Classification: 430.305.305.330.315.310