

Leak-Free Load-Control Valves size 40

$Q_{max} = 1300 \text{ l/min [340 gpm]}$, $p_{max} = 420 \text{ bar [6000 psi]}$
Seat-valve, two-stage hydraulic, cartridge design
Series CINDY 40-B-C...



- Two-stage load-control valve and bypass check valve are functionally combined in one coaxial valve assembly
- Leak-free load holding
- Pilot ratio 113:1
- The control assembly is guaranteed to close it closes even with a broken spring
- Various pilot-pressure ranges can be chosen
- All exposed parts with zinc-nickel plating
- Various types of pilot control, matched to your system, can be supplied
- Low-noise operation thanks to specially shaped control grooves

1 Description

Whenever large loads are to be precisely moved, placed and held, or work access platforms must maintain their position and withstand high forces, then leak-free load-control valves from the CINDY series are the right solution. Load-control valves in this series prevent hydraulic actuators from running ahead of the available oil supply. In one

valve, they combine the functions of load-holding, safety and pipe-rupture protection. Leak-free load-control valves in this series are ideally suited for use in high-pressure applications up to 420 bar (6000 psi). With a variety of optional components, the series can be extended and adapted to the requirements of the system.

2 Symbol

Variant A

Influenced by return-line pressure
(pressure in A is additive to opening pilot pressure).

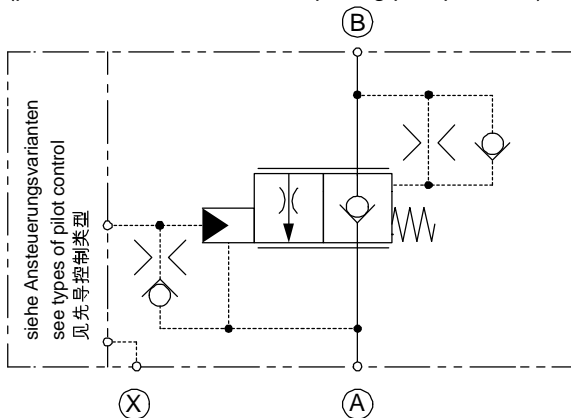

Variant L

Not influenced by return-line pressure
(drain line is required).

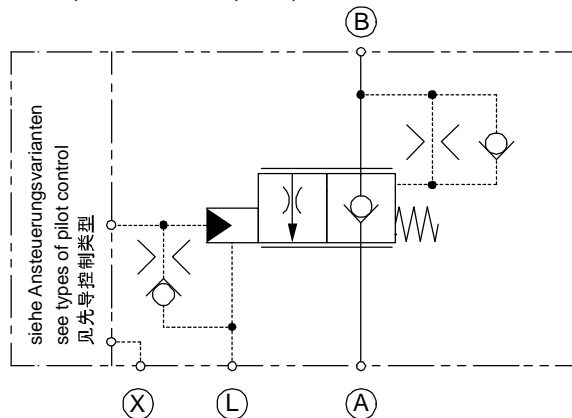

3 Technical data

General characteristics		Description, value, unit		
Designation		Leak-free load-control valve		
Design		Seat-valve, two-stage hydraulic, cartridge design		
Size		Size 40		
Mounting method		Factory standards 1x cylinder screw with internal hexagon M10x22 DIN EN ISO 4762, – grade 12.9		
Actuator / drive ports	A, B	∅ 38 mm	[∅ 1.49 inch]	(factory standards)
Pilot ports (internal variant)	X	∅ 4 mm	[∅ 0.15 inch]	(factory standards)
	(external variant)	G ¼"	ISO 1179-1	
Drain ports	L	∅ 4 mm	[∅ 0.15 inch]	(factory standards)
Weight		4.5 ... 4.8 kg	[9.92...17.63 lbs]	
Mounting attitude		unrestricted		
Ambient temperature range		- 25 °C ... +100 °C	[-13 °F ... +212 °F] (others on application)	
Surface corrosion protection		Outside parts: Zinc-nickel coating Mounting screws zinc-flake coated (e.g. with Geomet® finish)		

Hydraulic characteristics		Description, value, unit		
Maximum pressure at the flow- or return port A		420 bar	[6000 psi]	
Maximum pressure at the actuator- / load port B		420 bar	[6000 psi]	
Maximum pressure at the pilot port X		420 bar	[6000 psi] (restrictions possible - see section types of pilot control 4.4)	
Maximum flow rate		1300 l/min	[340 gpm] (higher flow rates on application)	
Flow direction		A → B, free flow through check valve B → A, controlled flow		
Operator type		hydraulic proportional or electro proportional		
Opening pilot ratio		113:1		
Hydraulic fluid		HL and HLP mineral oil to DIN 51 524; for other fluids, please contact BUCHER		
Hydraulic fluid temperature range		- 25 °C ... + 80 °C	[-13 °F ... +176 °F]	
Temperature rating of seals	NBR	- 25 °C... + 100 °C	[-13 °F ... +212 °F]	
	FKM	- 20 °C ... + 200 °C	[-4 °F ... +392 °F]	
	MIL	- 55 °C ... + 80 °C	[-67 °F ... +176 °F]	
Viscosity range		2.8... 1500 mm ² /s (cSt), recommended 10...380 mm ² /s (cSt)		
Minimum fluid cleanliness Cleanliness class to ISO 4406 : 1999		class 20/17/14		

4 Construction and function

The functions of the control assembly are subdivided into the following positions:

4.1 Neutral position

The load pressure and the compression spring act on the control spool in the closing direction. The valve is closed with no leakage.

4.2 Lifting (flow direction from A → B)

The pump pressure at port A opens the valve against the "light" compression spring and the load. The pilot spool and control spool move together in the opening direction. Oil flows from A → B and the valve functions as a check valve.

4.3 Lowering (flow direction from B → A)

The pilot pressure at port X acts on the pilot piston and against the control springs. The pilot spool opens. As a result, the load pressure B is discharged to port A via the metering grooves in the pilot spool. The progressive characteristic of the pre-opening phase ensures that lowering begins smoothly and without jerks.

If the pilot pressure at port X is increased, the pilot spool opens further. The change in the pressure conditions at the control spool means that it follows the pilot spool in the opening direction. The oil flows from B → A.

Neutral position
(Symbol for 4.1)

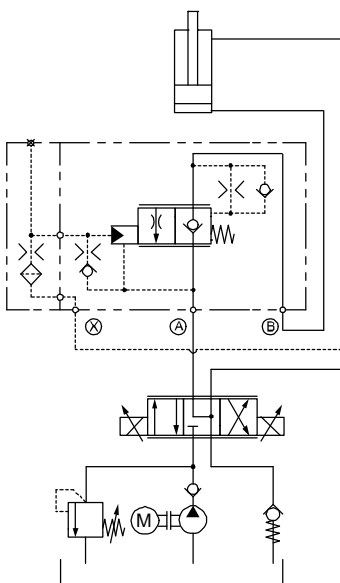

Lifting (A → B)
(Symbol for 4.2)

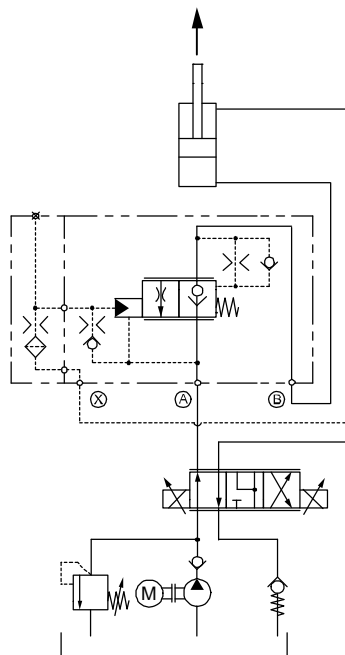

Lowering (B → A)
(Symbol for 4.3)

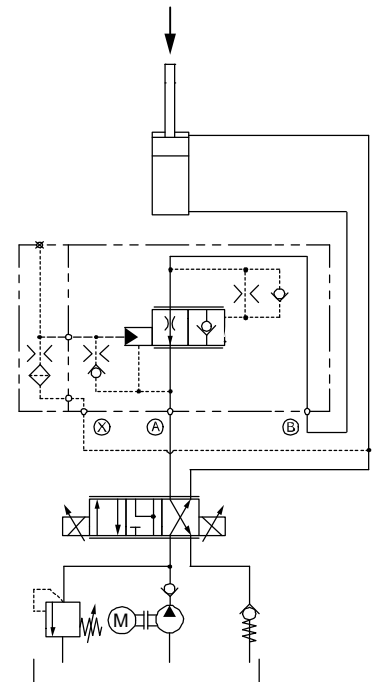

4.4 Types of pilot control

Cover types / applications	Type "G"	Type "D"	Type "K"	Type "H"	Type "R"	Type "E"
Cylinder application (external pilot signal)	✓✓	×	×	✓	✓	✓✓
Cylinder application (pilot signal from opposite line)		✓✓			×	×
Motors / Winches	×		✓✓	×	×	×
Motors for slewing drives	×	✓✓	×	×	×	×

Explanation of symbols: ✓✓ = normal ✓ = possible × = not possible

4.4.1 Standard damping cover, type "G"

Pilot control type "G" is recommended for external control, or with low-oscillation applications. This control cover can only be damped with an inlet orifice. Stroke-dependent damping is not possible with this cover.

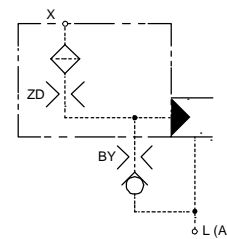

4.4.2 Stroke-dependent damping cover, type "D"

The type "D" cover is recommended for handling pilot signals that come from the opposite actuator line and for applications that are susceptible to oscillations. Thanks to the pilot piston's stroke-dependent damping system, oscillation-prone applications can be started in a very stable manner. The starting pressure peak is reduced because in the starting zone the valve responds quickly to the pilot signal.

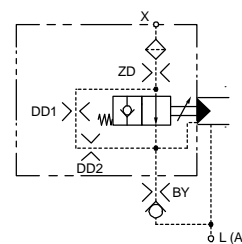

4.4.3 Stroke-dependent damping cover with metering grooves, type "K"

The stroke-dependent damping cover with metering grooves, type "K", is recommended for applications that are susceptible to oscillations, such as hydraulic motors (e.g. winches).

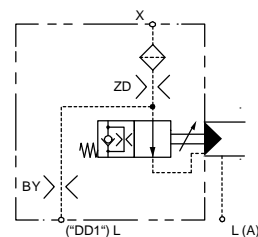

4.4.4 Hydromechanical stroke-limiting cover, type "H"

With the type "H" pilot control, the stroke of the load-control spool can be limited from outside the valve to achieve a particular flow rate or speed. This reduces the valve resolution.

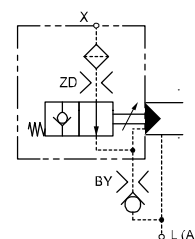

4.4.5 Hydraulic pressure-reducing valve cover type "R"

Pilot control type "R" denotes the version in which the incoming pilot pressure is reduced to a preset level. This function is needed when working with compensated and over-compensated applications, and the actual pilot pressure in the pilot chamber must not exceed 19 bar. The small leakage flow from the pressure reducing valve is discharged through an internal drain connection. The maximum allowable inlet pressure at port X is 100 bar. Because compensated and over-compensated systems must always be externally controlled, an inlet orifice is not normally required.



IMPORTANT!: Only available in return pressure independent version (L).

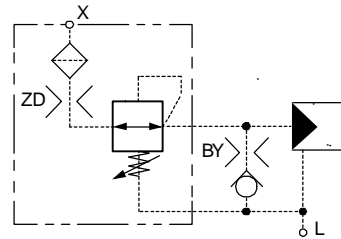

4.4.6 Electroproportional pressure-reducing valve cover type "E"

The type "E" control can be used for electroproportional control. In this case, the inlet signal at port X is reduced to a level proportional to the applied control current. The small flow of pilot oil from the pressure reducing valve is led away through an internal drain connection or a separate drain port. This control type is only intended for external pilot oil supplies, and it is essential to use a back-pressure-independent body (L).

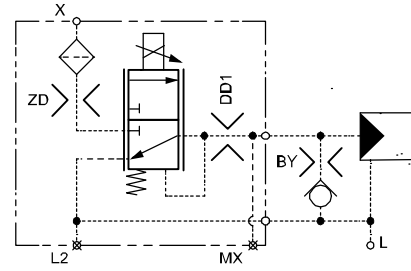

Hydraulic characteristics	Description, value, unit	
Pilot-oil supply at X	min. 30 bar max. 350 bar	[min. 435 psi] [max. 5000 psi] *
Permissible tank pressure at L (static)	max. 5 bar	[max. 70 psi]
Flow rate (pump) available at X	min. 2 l/min	[min. 0.5 gpm]
Pilot-oil consumption / Leakage flow rate	< 0.1 l/min (I = 0) < 0.5 l/min (I = max)	[< 0.026 gpm (I = 0)] [< 0.125 gpm (I = max)]
Hysteresis (with PWM control; pulse frequency 100 Hz)	0.5 bar	[7.1 psi]
Pilot-pressure control range	0...20 bar	[0...285 psi] *

* Other values on request

Electrical characteristics	Description, value, unit	
Nominal voltage	12 V DC	24 V DC
Resistance R 20	5.3 Ω ± 5 %	21.2 Ω ± 5 %
Maximum current at 100% duty cycle	1500 mA	750 mA
Power consumption at operating temperature (with increased resistance)	18 W	18 W
Control current at start of opening	~ 600 mA	~ 300 mA
Control current when fully open	~ 1400 mA	~ 700 mA
Relative duty cycle	100 %	
Insulation class	180 °C (VDE 0580:H)	[356 °F]
Protection class	IP 65 (DIN VDE 0470)	
Connector plug type	AMP Junior Timer Deutsch Plug DT04-2P	



IMPORTANT! Only available in return pressure independent version (L).

General:

The series-connection of the orifices allows the opening time, the closing time, the start of opening, and the full extent of opening to be matched to the requirements of the application.

5 Performance graphs

measured with oil viscosity 33 mm²/s (cSt)

$\Delta p = f(Q)$ Pressure drop - Flow rate characteristic

Lifting A → B

(through cartridge valve only)

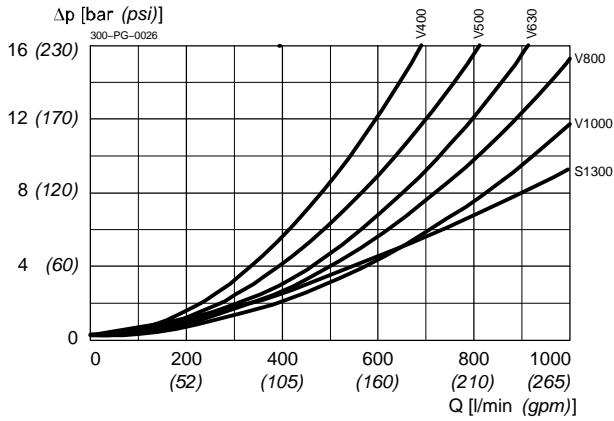

$\Delta p = f(Q)$ Pressure drop - Flow rate characteristic

Lowering B → A

(through cartridge valve only)

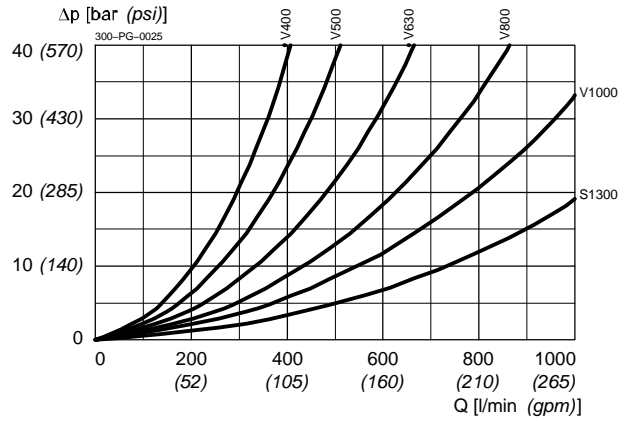

6 Available modules

6.1 Pilot oil connection (X) internal via mounting hole

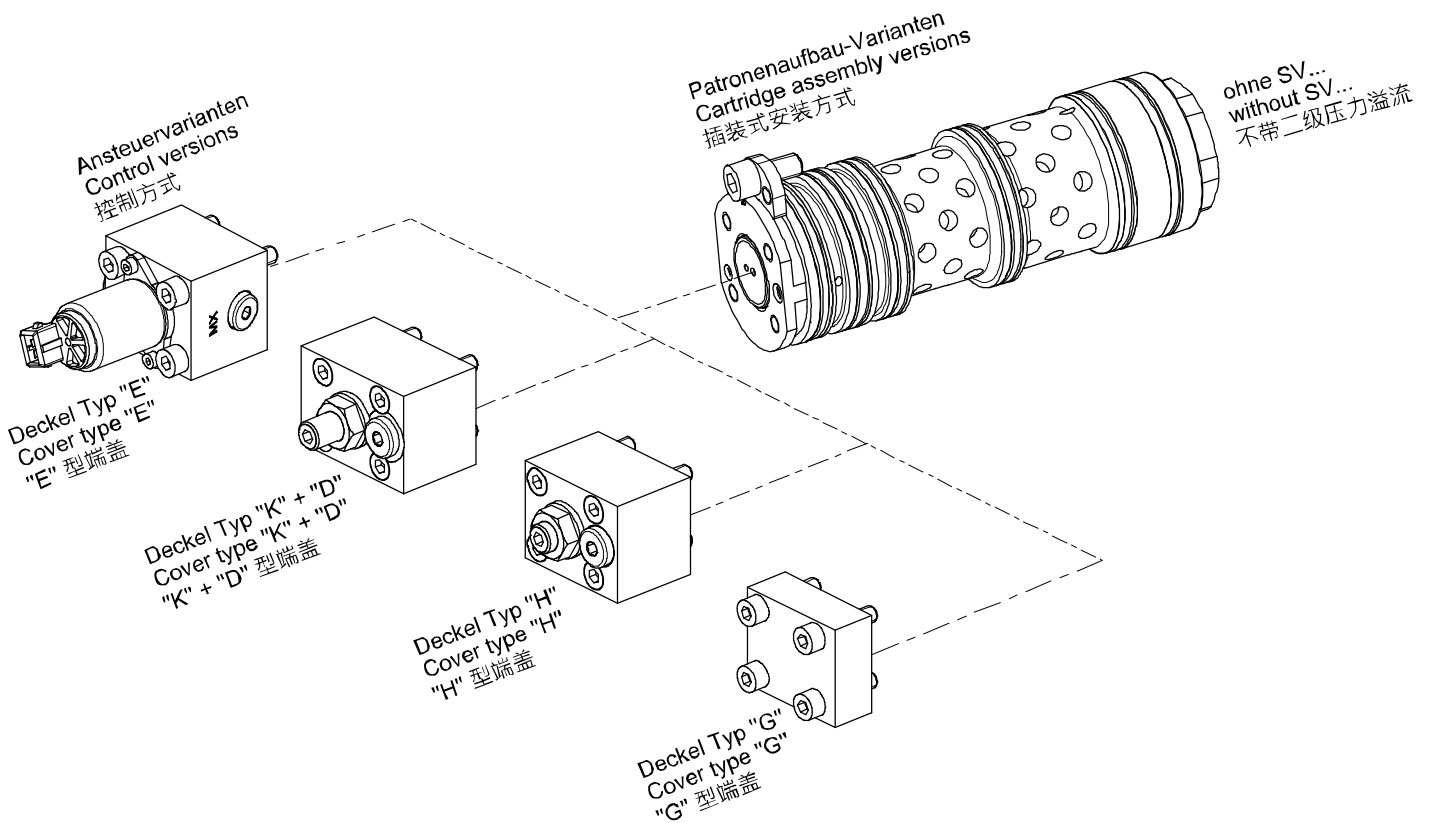

6.2 Pilot oil connection (X) external piped via cover

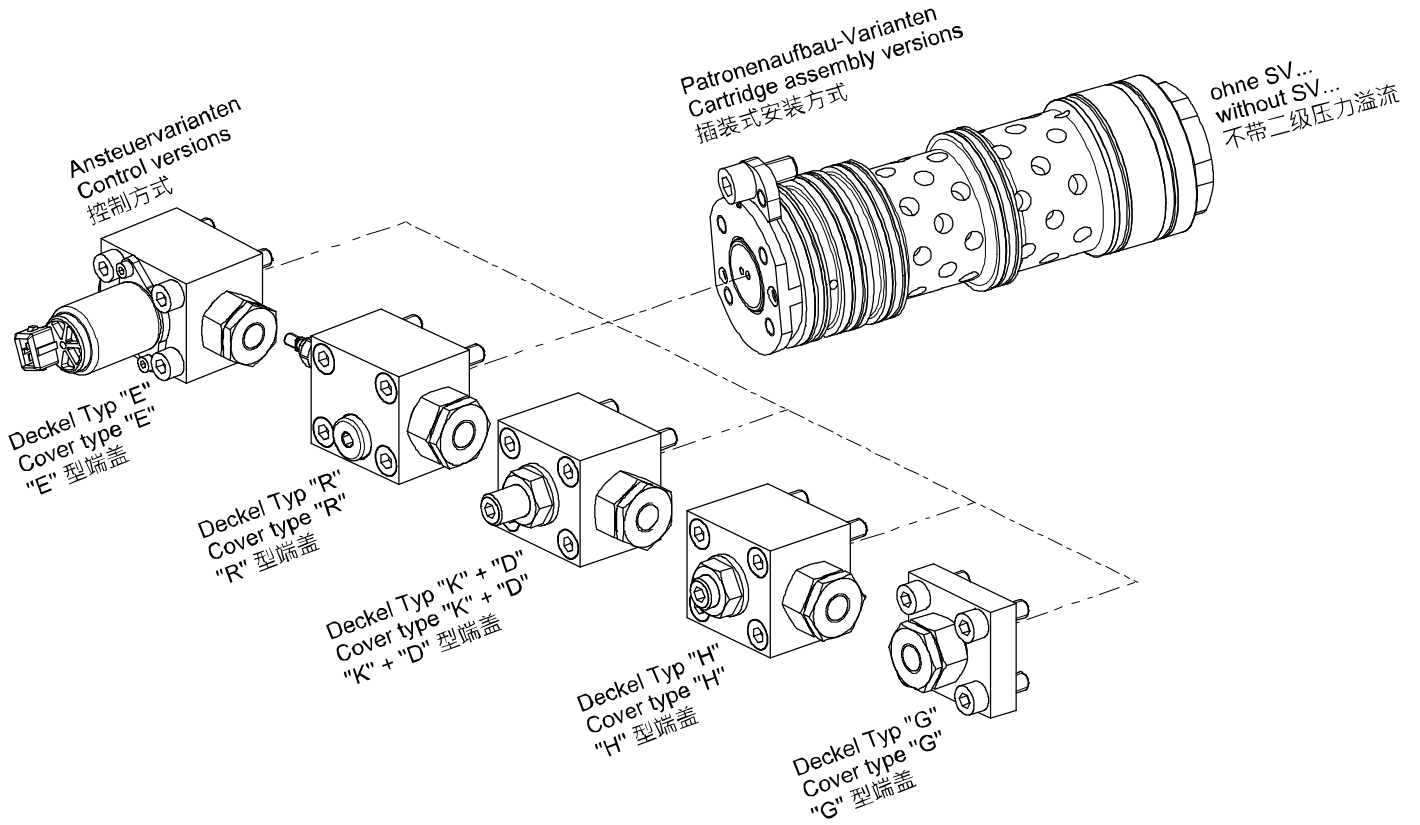

7 Dimensions & sectional view

7.1 Body and control variants for control oil connection (X) internal via mounting hole

Standarddämpfungsdeckel Typ "G"
Standard damping cover type "G"

"G" 型标准阻尼功能端盖

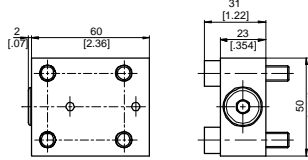

Hubabhängiger Dämpfungsdeckel Typ "D"
Hubabhängiger Kerbdämpfungsdeckel Typ "K"
Stroke-dependent damping cover type "D"
Stroke-dependent damping cover with metering grooves type "K"

"D" 型行程相关阻尼功能端盖
"K" 型行程相关阻尼功能端盖·带沟槽

- * = werkseitige Einstellung
- * = factory setting
- * = 工厂设定

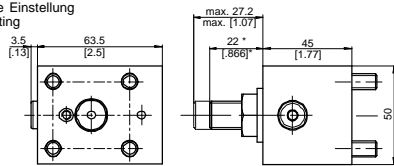

Hydromechanischer Hubbegrenzungsdeckel Typ "H"
Hydromechanical stroke-limiting cover type "H"

"H" 型机-液行程限制功能端盖

- * = werkseitige Einstellung
- * = factory setting
- * = 工厂设定

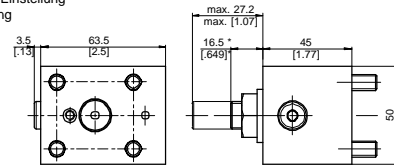

Elektronischer proportionaler Druckminderventildeckel Typ "E"
Electronic proportional pressure reducing valve cover type "E"

"E" 型电比例减压阀功能端盖

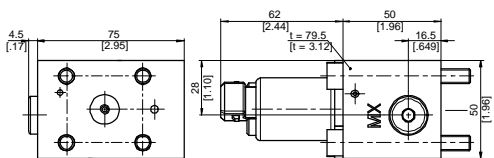

Beispiel für die Masseinheit:
Example for the dimensional units:
尺寸单位举例:
0.79 = 0.79 millimeter
[.031] = 0.031 inch

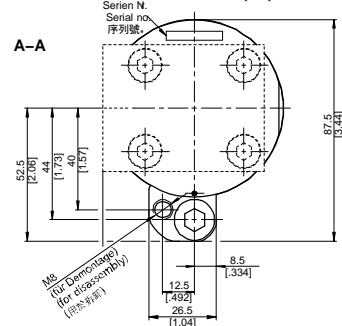
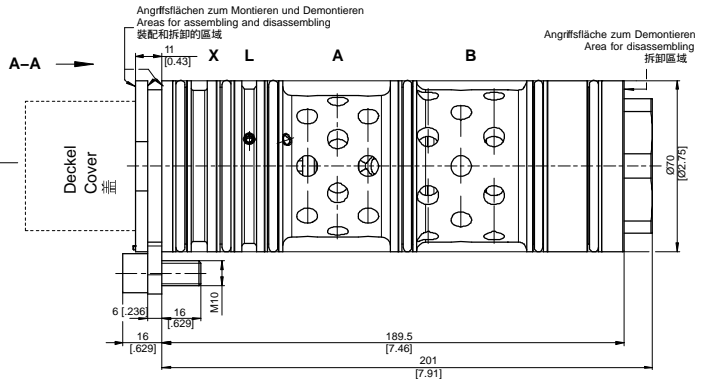

ATTENTION!

The force for assembling or disassembling the load control valve, should only be applied on the designated faces or threads.

Assemble or disassemble by hits on the load control valve is not allowed – Danger of losing pressure loaded parts!

7.2 Body and control variants for pilot oil connection (X) externally piped via cover

Standarddämpfungsdeckel Typ "G"

Standard damping cover type "G"

"G" 型标准阻尼功能端盖

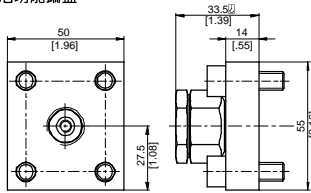

Beispiel für die Masseinheit:
Example for the dimensional units:
尺寸单位举例:
0.79 = 0.79 mm millimeter
[.031] = 0.031 " inch

Hubabhängiger Dämpfungsdeckel Typ "D"
Hubabhängiger Kerbdämpfungsdeckel Typ "K"
Stroke-dependent damping cover type "D"
Stroke-dependent damping cover with metering grooves type "K"

"D" 型行程相关阻尼功能端盖

"K" 型行程相关阻尼功能端盖，带沟槽

* = werkseitige Einstellung

* = factory setting

* = 工厂设定

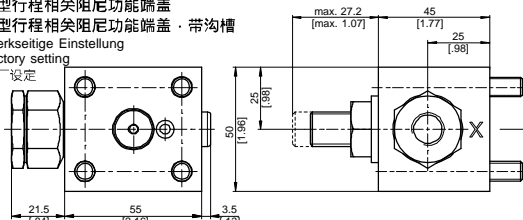

Hydromechanischer Hubbegrenzungsdeckel Typ "H"
Hydromechanical stroke-limiting cover type "H"

"H" 型机-液行程限制功能端盖

* = werkseitige Einstellung

* = factory setting

* = 工厂设定

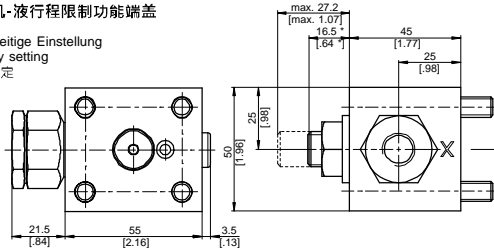

Hydraulischer Druckminderventildeckel Typ "R"
Hydraulic pressure-reducing valve cover type "R"

"R" 型减压阀功能端盖

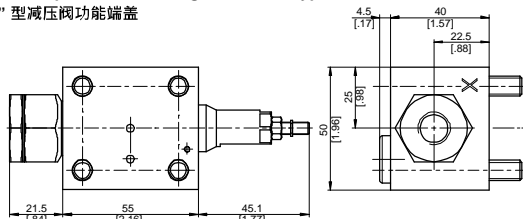

Elektronischer proportionaler Druckminderventildeckel Typ "E"
Electronic proportional pressure reducing valve cover type "E"

"E" 型电比例减压阀功能端盖

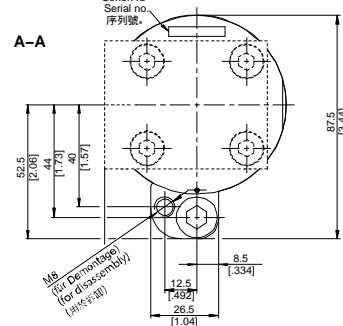
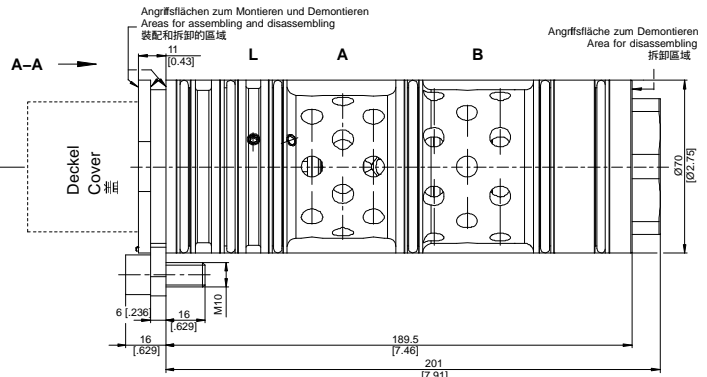
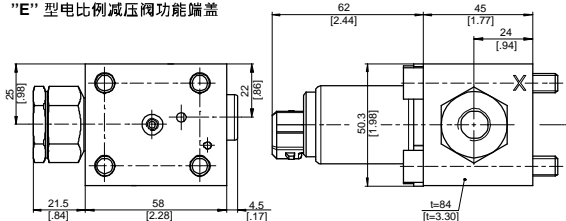

ATTENTION!

The force for assembling or disassembling the load control valve, should only be applied on the designated faces or threads.

Assemble or disassemble by hits on the load control valve is not allowed – Danger of losing pressure loaded parts!

7.3 Cavity type



With the external pilot oil connection (X) variant, the bore X (Ø4) incl. recess can be omitted.
With the version A (influenced by return-line pressure), the bore L (Ø4) incl. recess can be omitted.

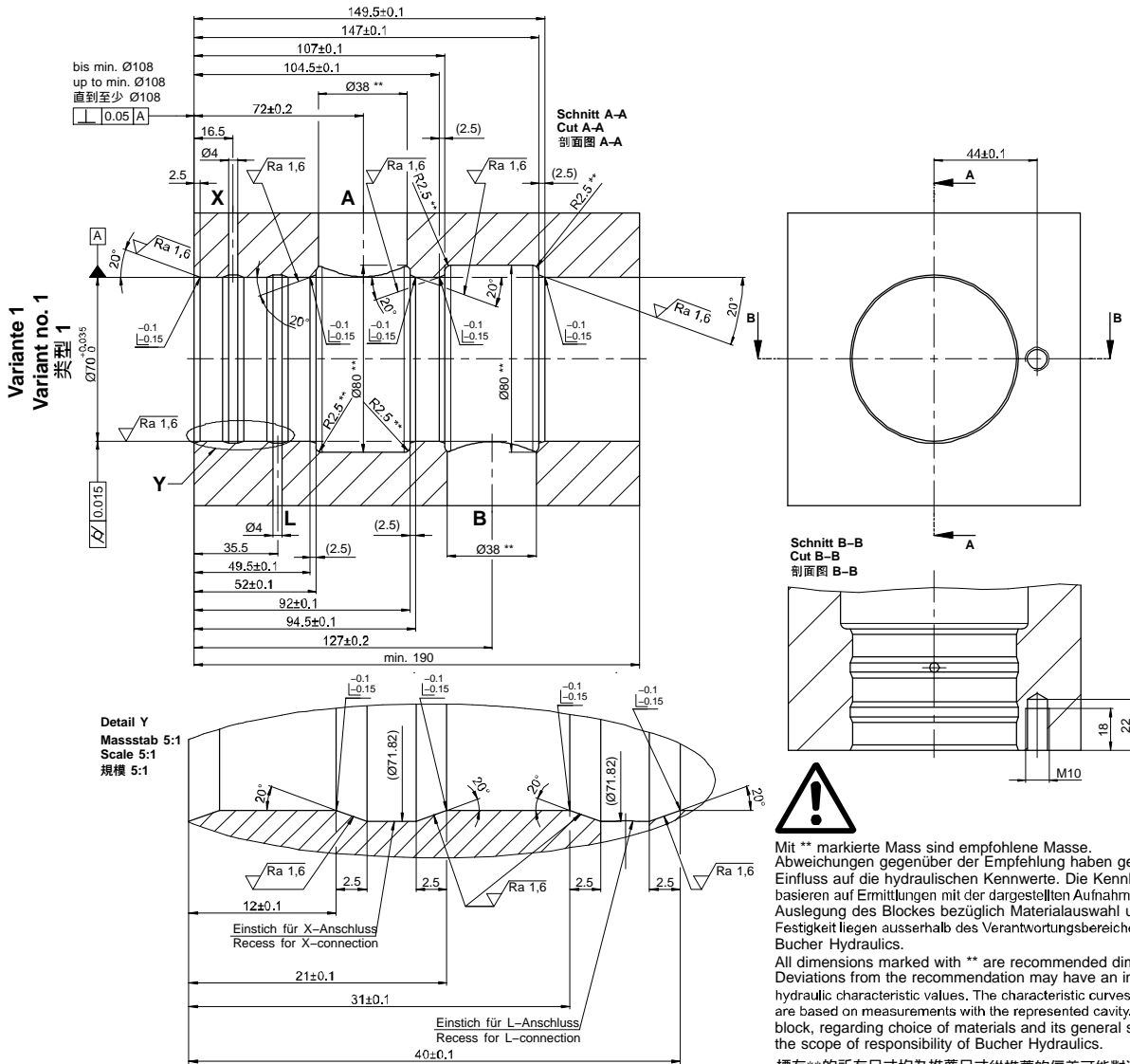

Mit ** markierte Mass sind empfohlene Masse. Abweichungen gegenüber der Empfehlung haben gegebenenfalls Einfluss auf die hydraulischen Kennwerte. Die Kennlinien im Datenblatt basieren auf Ermittlungen mit der dargestellten Aufnahmebohrung. Auslegung des Blockes bezüglich Materialauswahl und allgemeine Festigkeit liegen ausserhalb des Verantwortungsbereiches von Bucher Hydraulics.

All dimensions marked with ** are recommended dimensions. Deviations from the recommendation may have an influence on the hydraulic characteristic values. The characteristic curves in the data sheet are based on measurements with the represented cavity. Design of the block, regarding choice of materials and its general strength are beyond the scope of responsibility of Bucher Hydraulics.

標有**的所有尺寸均為推薦尺寸從推薦的偏差可能對液壓特性值的影響。數據表中的特徵曲線基於所表示的腔的測量值。關於材料選擇及其一般強度的塊塊設計超出Bucher Hydraulic的責任範圍。

Variante 2
(übrige Masse – siehe Variante 1)

Variant no. 2
(all other dimensions – see variant no. 1)

类型 2
(其它所有尺寸 – 参见变量 1)

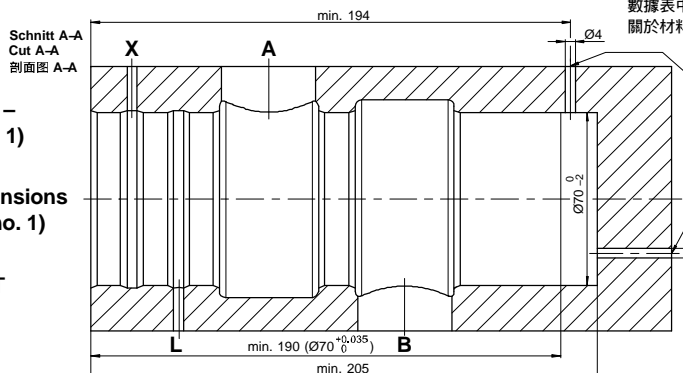

Die Bohrung Ø70_{-0.2} muss mit einer Bohrung Ø4 (radial oder axial) drucklos mit Atmosphäre verbunden werden!

The hole Ø70_{-0.2} must be connected to atmosphere by a hole of Ø4, either in axial or radial direction!

Ø70_{-0.2} 孔必須通過一個 Ø4 的轴向 (或徑向) 孔連通大氣。

Toleranzen nach:
Tolerances according to DIN ISO 2768-mK
公差基于

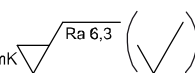

+0.2
-0.2

	√Ra 1,6	√Ra 6,3
Rauheitsklasse Roughness class 粗糙度等級	N7	N9
Rz [µm]	10	40

8 Options

8.1 Load-pressure-overcompensated model

This version with compensation orifice (KD) is recommended for long boom systems, e.g. the telescopic booms of mobile cranes. The compensation, alternatively the overcompensation, has the effect of limiting the speed as the load pressure increases, and this in turn raises machine safety levels.

During the lowering function B → A (with a maximum pilot pressure of 19.8 bar), the cylinder's retraction speed is influenced by the compensation orifice KD. In spite of the constantly changing kinematics and the resulting increase in the load pressure, the lowering speed:

- is held almost constant even without a compensation orifice (standard model)
- is reduced with a compensation orifice (overcompensated model)

The compensation orifice in the pilot spool has the effect that, as the load pressure increases, the pressure acting on

the control spool in the closing direction also rises. As a result, the control spool throttles the B → A flow area. To ensure that this function operates properly, these valve types must always be externally piloted.



ATTENTION!

A prerequisite is that the pilot pressure acting on the pilot piston is limited to max 19.8 bar. A higher pressure will prevent the speed-limiting function from working.



IMPORTANT!

To ensure that this function operates properly, the back-pressure-independent variant L should be used.

Characteristic curves (examples)

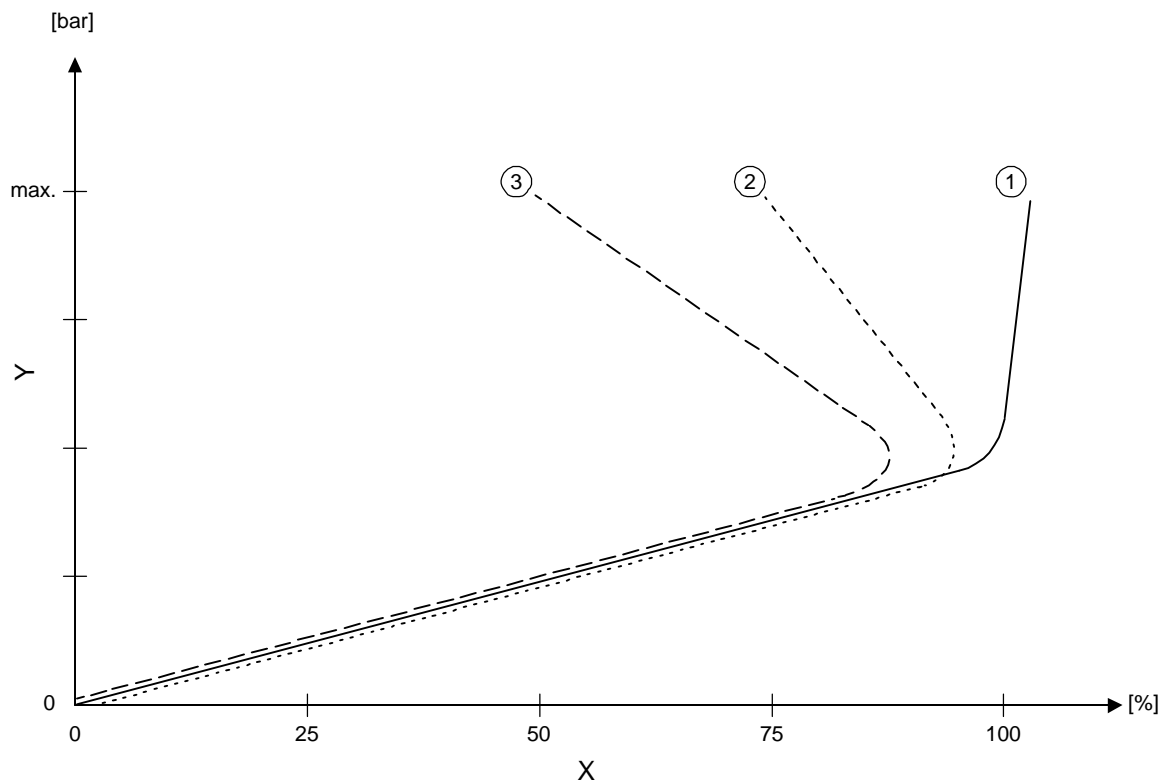

X	Flow B → A
Y6	Load pressure

1	Load-pressure-compensated model (without compensation orifice, KD)
2	Approx. 25 % overcompensated (KD Ø 1.8)
3	Approx. 50 % overcompensated (KD Ø 1.5)

9 Safety instructions

**IMPORTANT!:**

Designing load-control valves requires specialist technical knowledge and product knowledge. Safety applications must be verified by adequate tests to ensure safety in actual use.

9.1 Assembly / disassembly

**IMPORTANT!:**

The valve may only be used for its intended purpose within its nominal rating. If you plan to use it outside the nominal rating, you must contact the valve manufacturer.

The ultimate responsibility for safety in the installation and use rests with the end-machine manufacturer of the mobile application.

**IMPORTANT!:**

Seal kit with the external seals is available on application.

**IMPORTANT!:**

The port threads conform to DIN 3852-2. Use screws to DIN EN ISO 4762, grade 12.9, to mount the valve.

Tightening torques as per the manufacturer's instructions. These can be found on our website: www.bucherhydraulics.com (LOGIntern area; registration required)

**IMPORTANT!:**

Protect seals and flange faces from damage. The mating flange face must be of the quality specified in the data sheet! Pay attention to the port designations.

10 Application examples

10.1 Cylinder application

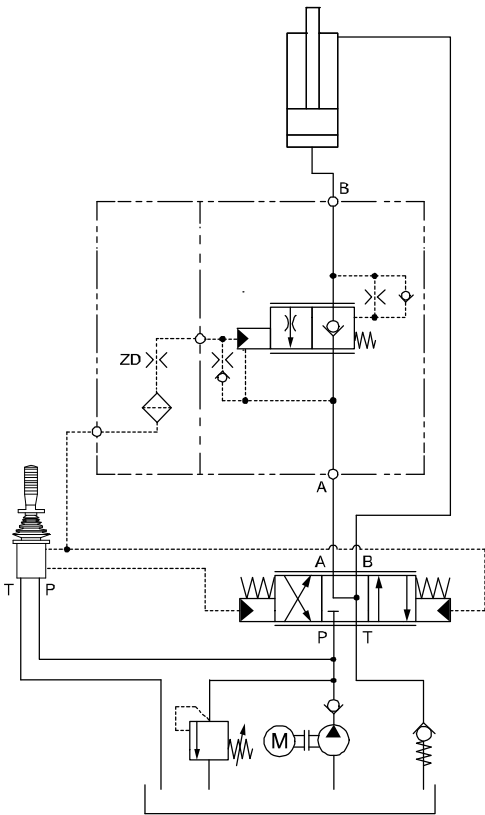

10.2 Motor application

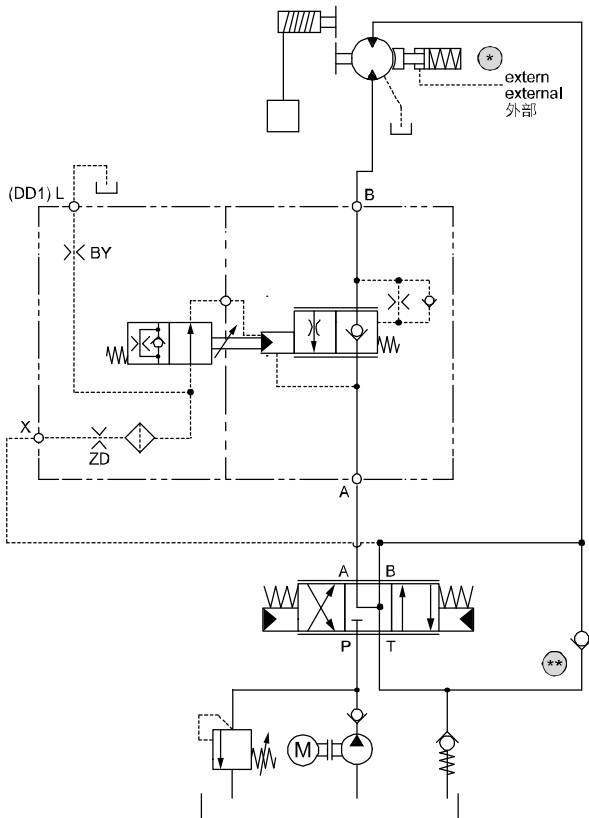

RECOMMENDATION

- * Mechanical brake, externally controlled for reduced lowering pressures in the supply line of the motor.
- ** Anti-cavitation check valve for additional safety.



ATTENTION!

Cavitation danger!

Control from the opposite line:

To open the valve, we recommend control from the opposite line. This method ensures that the actuator cannot run ahead of the incoming flow.

Brake release

(unlocking the mechanical brake):

The mechanical brake must be released before the load-control valve for winches is opened. This prevents draining of the return line to the main spool before the valve opens, thus preventing load fall.

11 Ordering code

e.g. **CINDY** **40** - **B** - **C** **N** **D** - **V0400** - **A** - **G...** - **...** - **I** - **...** - **...**

- CINDY = series
- 40 = size 40
- B = model / version
- C = cartridge design
- N = NBR (Nitrile) seals (standard)
- V = FKM (Viton) seals
- T = MIL (low temperature) seals
- D = Geomet (zinc flake) mtg. screw M10x22-12.9
- V0400 = progressive-spool, lowering flow rate 400 l/min [105 gpm] *
- V0500 = progressive-spool, lowering flow rate 500 l/min [132 gpm] *
- V0630 = progressive-spool, lowering flow rate 630 l/min [167 gpm] *
- V0800 = progressive-spool, lowering flow rate 800 l/min [212 gpm] *
- V1000 = progressive-spool, lowering flow rate 1000 l/min [265 gpm] *
- S1300 = standard-spool, lowering flow rate 1300 l/min [340 gpm] *
- A = influenced by return-line pressure in A
- L = not influenced by return-line pressure
- G... = standard cover
- D... = stroke-dependent damping cover
- K... = stroke-dependent damping cover with metering grooves
- H... = hydromechanical stroke-limiting cover
- R... = hydraulic pressure-reducing valve cover ¹⁾
- E... = electroproportional pressure-reducing valve cover ¹⁾
- ... = orifice combination (is factory-defined)
- I = internal: pilot oil connection (X) via mounting hole
- E = external: pilot oil connection (X) pipped via cover
- (blank) = without load pressure overcompensation
- 25 = with load pressure overcompensation 25% / compensation orifice KD Ø 1.8
- 50 = with load pressure overcompensation 50% / compensation orifice KD Ø 1.5
- 52 = with load pressure overcompensation 52% / compensation orifice KD Ø 1.4
- 54 = with load pressure overcompensation 54% / compensation orifice KD Ø 1.3
- 24DI = data for "E" cover only: AMP Junior Timer, 24 VDC (standard)
- 12DI = data for "E" cover only: AMP Junior Timer, 12 VDC
- 24DT = data for "E" cover only: Deutsch plug DT04-2P, 24 VDC
- 12DT = data for "E" cover only: Deutsch plug DT04-2P, 12 VDC

*) at 33 bar [478 psi] Δp from B → A
other lowering flow rates on application.

¹⁾ Only available in return pressure independent version (L).

12 Related data sheets

Reference	Description
300-D-9050098	Project Engineering & User Information, Series CINDY, SAE-flange, manifold and cartridge design
300-D-9050102	Technical design sheet for CINDY load-control valves in cylinder applications
300-S-9050030	Spare Parts Information, Series CINDY as cartridge design



IMPORTANT!:

Additional documentation and 3D models (.stp or .igs format) can be downloaded from www.bucherhydraulics.com (LOGintern area; registration is necessary)

We also offer customised solutions. Please talk to our sales team.