

2/2 Solenoid Cartridge Valve, Size 6

$Q_{\max} = 20 \text{ l/min (5.3 gpm)}$, $p_{\max} = 315 \text{ bar (4500 psi)}$

Bidirectional leak-proof shutoff, direct acting, with EX-protected solenoid coil
Series EEX-W1C.B...

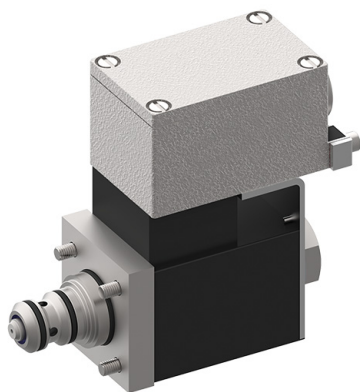

Valve:

- Bidirectional leak-proof shutoff
- De-energised closed
- Guided valve spool and poppet
- Available in two mounting versions
- With or without manual override

Solenoid coil:

- To IEC/EN 60079-0, IEC/EN 60079-7, IEC/EN 60 079-18
- For equipment in Category 2 (Zones 1 and 2)
- Certificate of conformity: BASEEFA 02 ATEX 0199 X

 II 2 G Ex e mb IIC T4 Gb

1 Description

The EEX-W1C.B... series of 2/2 solenoid operated directional seat valves are size 6, direct acting, pressure balanced, push-in cartridges. An EX-protected solenoid for explosive gas atmospheres (II 2 G) is used to provide electrical operation of the cartridge. In the normal condition (de-energised closed), flow is shut off without leakage. The core element operates on the tried and tested principle of the guided poppet, and the guide spool has a seal. Two different mounting versions are available, which allows the designer to choose the insertion depth (flange 10.1 mm or 18 mm). These cartridge seat valves are also available with or without manual override. They are suitable where leak-tight shut-off functions are crucially important. Examples are where loads, tensions, or clamping forces must be held

without leakage. All external parts of the valve are corrosion-protected, and the valves are thus also suitable for use outdoors.

Ex: Solenoid conforms to the European standards IEC/EN 60079-0, IEC/EN 60079-7, IEC/EN 60079-18

e: Increased safety

mb: Encapsulation

Group IIC: For use in explosive gas atmospheres

T4: Max. surface temperature 135 °C

Gb: For use in Zone 1 (Zone 2) with foreseeable faults

Certificate of conformity:

BASEEFA 02 ATEX 0199 X

IECEx BAS13.0093 X (on request)

2 Symbol



3 Technical data

General characteristics	Description, value, unit
Designation	2/2 solenoid cartridge valve
Design	bidirectional leak-proof shutoff, direct acting poppet and valve-spool design (pressure balanced) with EX-protected solenoid
Mounting method	push-in cartridge, 4 mounting bolts M5 x 10

General characteristics	Description, value, unit
Tightening torque	5.2 Nm ± 5 % (4 ft.lbs ± 5 %)
Size	size 6, cavity type AA or cavity type AB
Weight	1.4 kg
Mounting attitude	unrestricted
Ambient temperature range	see hydraulic and electrical characteristics

Hydraulic characteristics	Description, value, unit
Maximum operating pressure	315 bar (4500 psi)
Maximum flow rate	20 l/min (5.3 gpm)
Flow direction	1 → 2 / 2 → 1, see symbols
Hydraulic fluid	HL and HLP mineral oil to DIN 51 524; for other fluids, please contact BUCHER
Ambient temperature range ¹⁾	-25 °C ... +80 °C (-13 °F ... +176 °F)
Hydraulic fluid temperature range ¹⁾	-25 °C ... +80 °C ²⁾ (-13 °F ... +176 °F) ²⁾
Viscosity range	10...500 mm ² /s (cSt), recommended 15...250 mm ² /s (cSt)
Minimum fluid cleanliness Cleanliness class to ISO 4406 : 1999	class 20/18/15

Electrical characteristics	Description, value, unit
Supply voltage	24 V DC 230 V AC <small>In AC solenoids, rectifier is integrated.</small>
Supply voltage tolerance	± 10 %
Ambient temperature range ¹⁾	-40 °C ... +40 °C (-40 °F ... +104 °F) (Operation as T4)
Temperature class	T1 ... T4
EX-protection marking	II 2 G, Ex e mb IIC T4 Gb
Nominal power consumption	31,9 W at 20 °C (31.9 W at 68 °F)
Relative duty cycle	100 %
Protection class to ISO 20 653 / EN 60 529	IP 54 <small>(with properly fitted cable gland and properly made cable connection)</small>
Electrical connection	Shipped without cable gland (M20 x 1.5) and without cable <small>Cable-entry temperature may exceed 70 °C</small>



IMPORTANT!:

1) The less favourable values from the hydraulic and electrical characteristics determine the temperature range of the whole valve.



IMPORTANT!:

2) The maximum fluid temperature must not exceed the permissible ambient temperature for the whole valve.

4 Performance graphs

measured with oil viscosity 33 mm²/s (cSt), coil at steady-state temperature and 10 % undervoltage

$p = f(Q)$ Performance limits

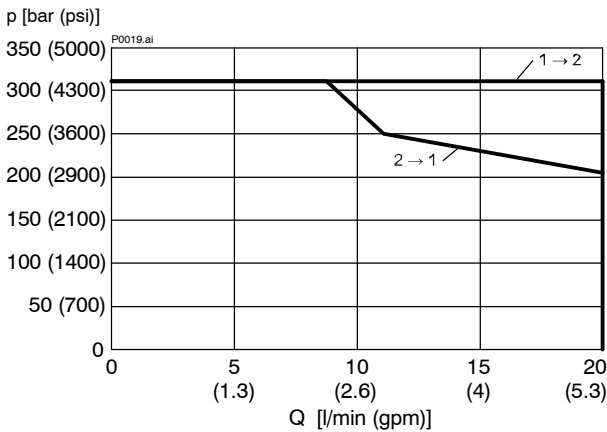

$\Delta p = f(Q)$ Pressure drop - Flow rate characteristic (1 ↔ 2)

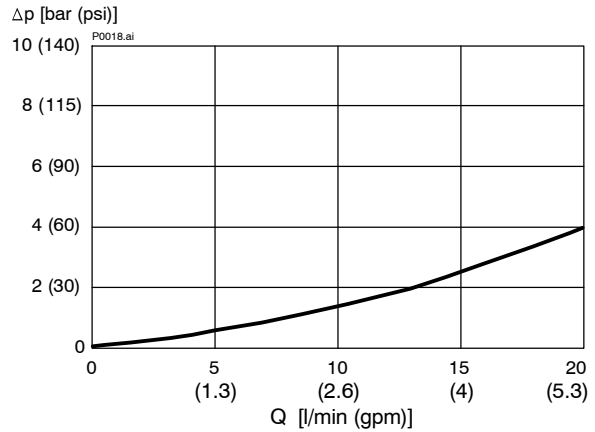

5 Installation information

COMMISSIONING

- For short-circuit protection, each solenoid must be preceded by a fuse conforming to B588 or IEC269 with a maximum rating of 2 A (AC) or 6 A (DC).
- The solenoid coils must only be operated when they are fitted on the associated valve. For more information on installation and commissioning, please refer to the operating instructions supplied with the solenoid coil.



ATTENTION!

Ratings given in the operating instructions
Pay attention to the relevant operating instructions! If in doubt, the ratings in the operating instructions apply.



ATTENTION!

Only qualified personnel with mechanical skills may carry out any maintenance work. Generally, the only work that should ever be undertaken is to check, and possibly replace, the seals. When changing seals, oil or grease the new seals thoroughly before fitting them.



ATTENTION!

Authorised persons

The tasks described here may only be carried out by authorised personnel. Authorised personnel are those who have electro-technical training (EN 60204-1).



IMPORTANT!

When fitting the cartridges, use the specified tightening torque for the mounting bolts. The marking "Valve End" on the adapter sleeve must be mounted towards the valve flange! No adjustments are necessary, since the cartridges are set in the factory.



IMPORTANT!

Minimum dimensions of the valve body
62.5 x 46 x 45.5 mm
Minimum dimensions of the mating body
101 x 46 x 43 mm
See also the user manual.

6 Dimensions & sectional view

6.1 Mounting depth „shallow“

6.2 Mounting depth „deep“ (without manual override)

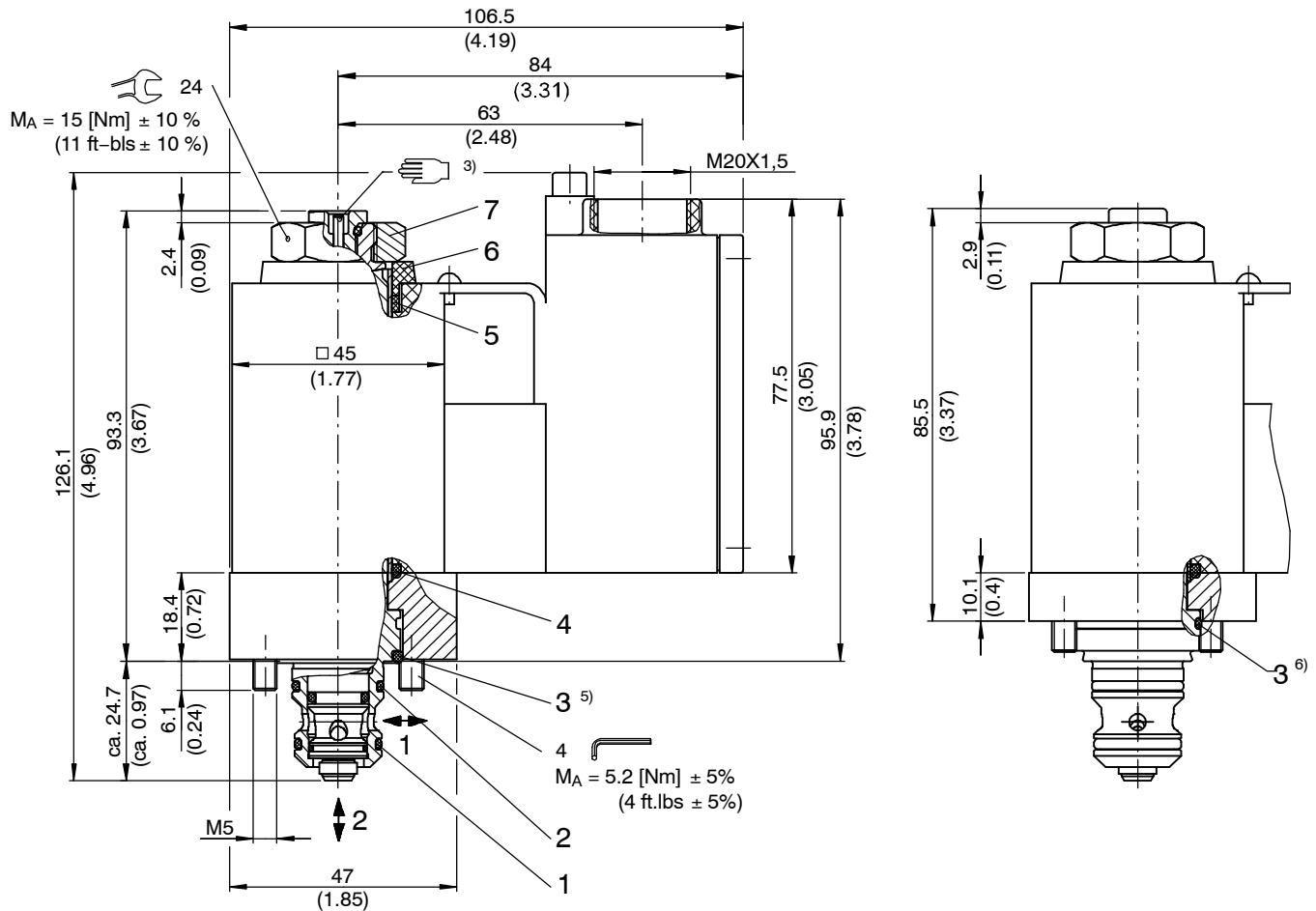

Seal kit no. DS-263-N ⁴⁾

Item	Qty. ⁵⁾	Qty. ⁶⁾	Description
1	1	1	O-ring no. 015 \varnothing 14,00 x 1,78 N90
2	1	1	O-ring no. 016 \varnothing 15,60 x 1,78 N90
3	1	---	O-ring no. 116 \varnothing 18,72 x 2,62 N70
	---	1	O-ring no. 021 \varnothing 23,52 x 1,78 N90
4	1	1	O-ring no. 116 \varnothing 18,72 x 2,62 V70
5	1	1	Seal solenoid EX EMB D25,3
6	1	1	Spacer ring solenoid EX EMB
7	1	1	6A/F hex DIN439B M16X1,5 KL04 VZ



IMPORTANT!:

- ³⁾ Can be chosen with or without manual override. (see ordering code).
- ⁴⁾ Seal kit with Viton seals, no. DS-263-V
- ⁵⁾ W1CB... / W1CD...
(mounting depth "shallow")
- ⁶⁾ W1CC... / W1CE...
(mounting depth "deep")

7 Ordering code

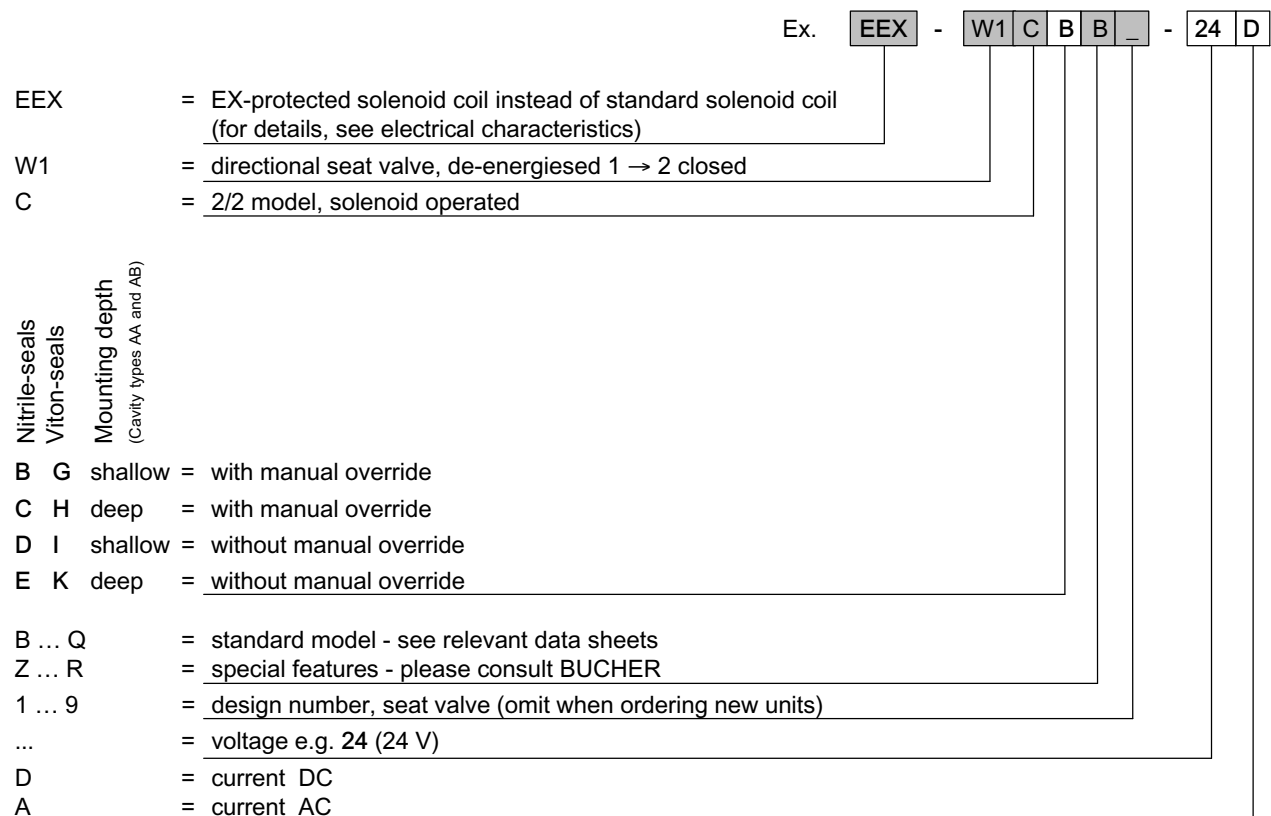

8 Related data sheets

Reference	(Old no.)	Description
400-P-040011	(i-32)	The form-tool hire programme
400-P-040101	(i-33.1)	Cavity type AA and AB
D14-2117D		Operating instructions for solenoid coil DC LISK
K14-2068D		Operating instructions for solenoid coil AC LISK
D14-2130D3		Operating instructions for solenoid coil DC LISK IEC (on request)
D14-2078D3		Operating instructions for solenoid coil AC LISK IEC (on request)

info.ch@bucherhydraulics.com

www.bucherhydraulics.com

© 2018 by Bucher Hydraulics AG Frutigen, CH-3714 Frutigen

All rights reserved.

Data is provided for the purpose of product description only, and must not be construed as warranted characteristics in the legal sense. The information does not relieve users from the duty of conducting their own evaluations and tests. Because the products are subject to continual improvement, we reserve the right to amend the product specifications contained in this catalogue.

Classification: 430.300.-.305.310.300