

Directional valve 3-way/2-position

$Q_{\max} = 10 \text{ gpm}$, $p_{\max} = 4500 \text{ psi}$

pneumatically operation, direct acting, poppet type

Type series: W1S_B...

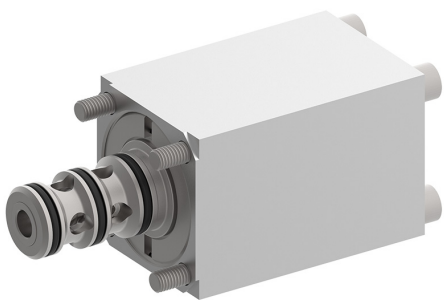

- Slip-in cartridge valve
- For cavity AC
- All external parts with zinc-nickel plating according to DIN EN ISO 19598
- Guided valve spool and poppet
- Control head is hard-anodized aluminium

Description

The 3-way/2-position directional seat valves, series W1S..., are size 6, pneumatically operated, direct acting, pressure balanced, push-in valves. In the normal condition (non-operated), flow in port 1 is shut off without leakage. They are designed on the tried and tested principle of the guided poppet, and the guide spool has a seal. This valve type has an overlapped spool. In the crossover position, all connections are thus disconnected, i.e., there is no connection between ports 1, 2, and 3 during the valve's switching period, with the result that only a minimal loss of the flow/pressure occurs. This is a very important bene-

fit in small-volume circuits, and in accumulator- and clamping systems. The pneumatic control head has a G1/8" threaded port for the air feed. All external parts of cartridge are zinc-nickel plated, the aluminum control head is hard-anodized, and the valve is thus suitable for use in the harshest operating environments. These valves are predominantly used in certain mobile and industrial applications where leak-tight shut-off functions are crucially important. Examples are where loads, tensions, or clamping forces must be held without leakage. For self-assembly, please refer to the section related data sheets.

Symbol

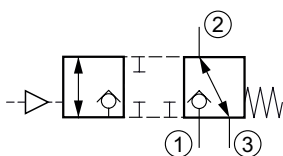

Technical data

General characteristics	Description, value, unit
Function group	Directional valve
Function	3-way/2-position
Design	Slip-in cartridge valve
Controls	pneumatical operation
Characteristic	direct acting, poppet type
Transition/central position of spool/piston	zero or overlap/positive (closed)
Construction size	nominal size 6
Mounting attitude	unrestricted
Weight	1.2 lbs
Cavity acc. factory standard	For cavity AC
Tightening torque steel	4 ft·lb
Tightening torque aluminium	4 ft·lb
Tightening torque tolerance	± 5 %
Minimum ambient temperature	- 13 °F
Maximum ambient temperature	+ 176 °F
Surface protection	All external parts with zinc-nickel plating according to DIN EN ISO 19598
Sealing material	see ordering code
Seal kit order number	NBR: DS-387-N / FKM: DS-387-V

Hydraulic characteristics	Description, value, unit
Maximum operating pressure	4500 psi
Maximum flow rate	10 gpm
Flow direction	see symbol
Hydraulic fluid	HL and HLP mineral oil according to DIN 51 524; other fluids on request!
Minimum fluid temperature	- 13 °F
Maximum fluid temperature	+ 176 °F
Viscosity range	10 ... 650 mm ² /s (cSt)
Recommended viscosity range	15 ... 250 mm ² /s (cSt)
Minimum fluid cleanliness (cleanliness class according to ISO 4406:1999)	class 20/18/15
Pilot operating media	compressed air
Pilot pressure	min. 90 psi

Performance graphs

measured with oil viscosity 33.0 mm²/s (cSt)

$p = f(Q)$ Performance limit

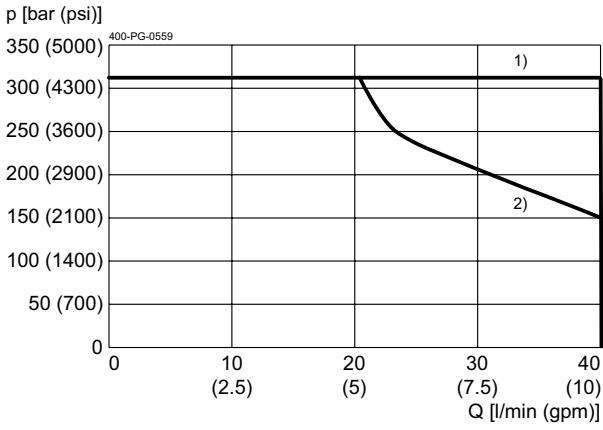

1) = 1 → 2, 2 → 1, 2 → 3
2) = 3 → 2

$\Delta p = f(Q)$ Pressure drop-flow rate characteristic

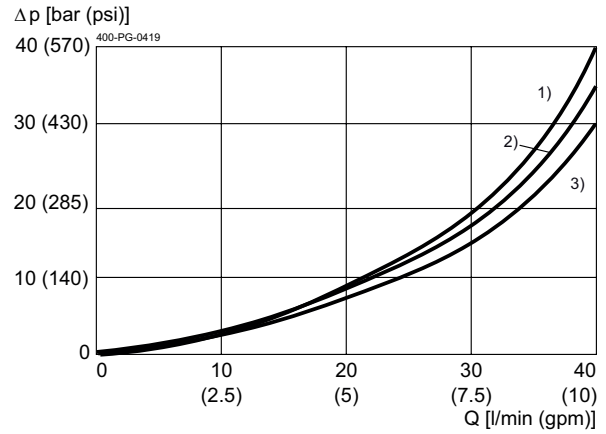

1) = 2 → 1; 2 → 3
2) = 1 → 2
3) = 3 → 2

Dimensions and sectional view

Beispiel für die Masseinheit:
Example for the dimensional units:
0.79 = 0.79 mm millimeter
(.031) = 0.031" inch

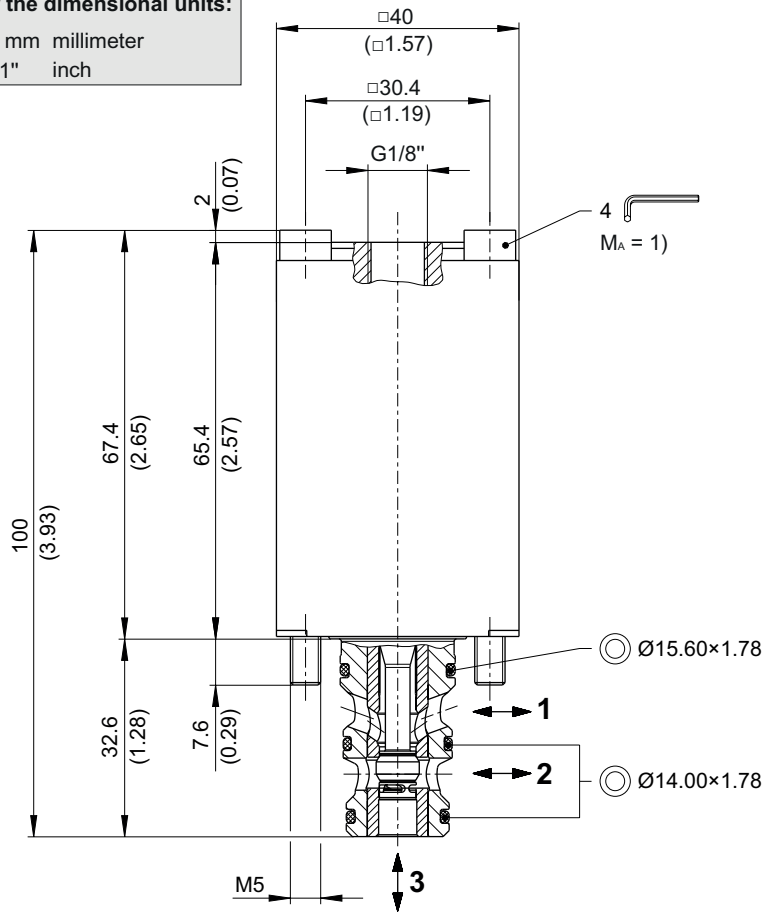

Installation information



ATTENTION!

Only qualified personnel with mechanical skills may carry out any maintenance work. Generally, the only work that should ever be undertaken is to check, and possibly replace, the seals. When changing seals, oil or grease the new seals thoroughly before fitting them.



NOTE!

1) When fitting the slip-in valves, use the specified tightening torque for the mounting screws. The value can be found in the chapter "Technical data".

Functional principle / Spool variants

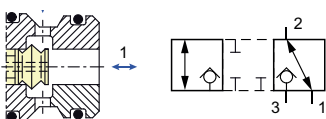

The "overlapped spool" model features a closed crossover characteristic i.e. during the valve's switching period, there is no connection between ports 3, 2, and 1 and therefore only a minimal loss of flow/pressure occurs. This is a very important benefit in small-volume circuits, and in accumulator- and clamping systems.

Ordering code

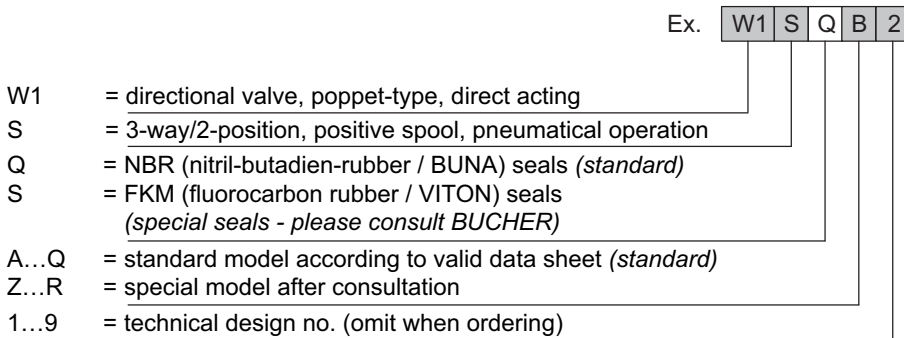

Related data sheets

Reference	Description
400-P-040011	Form tools
400-P-040111	Cavity AC