

Directional valve 3-way/2-position

$Q_{\max} = 32 \text{ l/min}$, $p_{\max} = 420 \text{ bar}$
switching solenoid, direct acting, poppet type
Type series: WSDPP32G-5P...



- Screw-in cartridge valve
- For cavity GP/C0830
- All external parts with zinc-nickel plating according to DIN EN ISO 19598
- Fits common cavity according to ISO and NFPA
- Reliable switching, even after long dwell times
- Low head loss
- Installation in threaded port body type GGP-38
- De-energized closed
- The slip-on coil can be rotated, and it can be replaced without opening the hydraulic envelope
- High pressure wet-armature solenoids
- Various plug-connector systems and voltages are available

Description

These 3-way/2-position solenoid operated directional seat valves, series WSDPP32G-5P..., are NG 5 / SAE 08, direct acting, pressure balanced screw-in valves with a 3/4-16 UNF mounting thread. They are designed on the poppet/seat principle, and therefore leak-free. The straightforward design delivers a good price/performance ratio and outstanding headloss/flow ratings. All external parts of the screw-in valves are zinc-nickel plated and are thus suitable for use in the harshest

operating environments. The slip-on coils can be replaced without opening the hydraulic envelope and can be positioned at any angle through 360°. These valves are used in mobile and industrial applications where leaktight shutoff functions are crucially important. Examples are where loads, tensions, or clamping forces must be held without leakage. For self-assembly, please refer to the section related data sheets.

Symbol

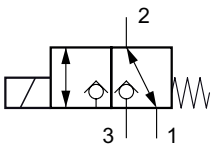

Technical data

General characteristics	Description, value, unit
Sales category	minimum order quantity required (see order details)
Function group	Directional valve
Function	3-way/2-position
Design	Screw-in cartridge valve
Controls	switching solenoid
Characteristic	direct acting, poppet type
MTTFd value	150 years
Construction size	NG 5 / SAE 08
Thread size	3/4-16 UNF-2A
Mounting attitude	unrestricted
Weight	0.67 kg
Cavity acc. ISO	fits into ISO 17209: 3/4-03-0-13
Cavity acc. NFPA	fits into NFPA/T3.5.50: 0.750-03-0-09
Cavity acc. factory standard	For cavity GP/C0830
Tightening torque steel	60 Nm
Tightening torque aluminium	60 Nm
Tightening torque tolerance	± 10 %
Minimum ambient temperature	- 30 °C
Maximum ambient temperature	+ 50 °C
Surface protection	All external parts with zinc-nickel plating according to DIN EN ISO 19598
Sealing material	see ordering code
Seal kit order number	NBR: DS-522-N / FKM: DS-522-V

Hydraulic characteristics	Description, value, unit
Maximum operating pressure	420 bar
Maximum flow rate	32 l/min
Flow direction	see symbol
Hydraulic fluid	HL and HLP mineral oil according to DIN 51 524; other fluids on request!
Minimum fluid temperature	- 25 °C
Maximum fluid temperature	+ 80 °C
Viscosity range	10 ... 500 mm ² /s (cSt)
Recommended viscosity range	15 ... 250 mm ² /s (cSt)
Minimum fluid cleanliness (cleanliness class according to ISO 4406:1999)	class 20/18/15

Electric characteristics	Description, value, unit
Actuator type	solenoid coil
Solenoid coils type	36X48/16.1
Supply voltage DC	12/24 V DC
Supply voltage tolerance	± 10 %
Maximum permissible power consumption	19 W
Switching time	Switching time measured at: U_N : $\Delta p = 300 \text{ bar}$; $Q = 15 \text{ l/min}$; $T_{\text{Ambient}} = 20 \text{ °C}$; $\vartheta = 46 \text{ mm}^2/\text{s}$ 30 ms (energizing) / 26 ms (deenergizing)
Relative duty cycle	100 %
Electrical connection coil	several connection types available, see ordering code
Protection class solenoid coil to ISO 20 653 / EN 60 529	several classes of protection available, see ordering code (with appropriate mating connector and proper fitting and sealing)



NOTE!

The switching time can be strongly dependent on flow rate, pressure, oil viscosity and the dwell time under pressure. In practice, the switching time may therefore deviate from the specified value range.

Performance graphs

measured with oil viscosity 33.0 mm²/s (cSt), coil at steady-state temperature and 10 % undervoltage

$p = f(Q)$ Pressure-flow rate

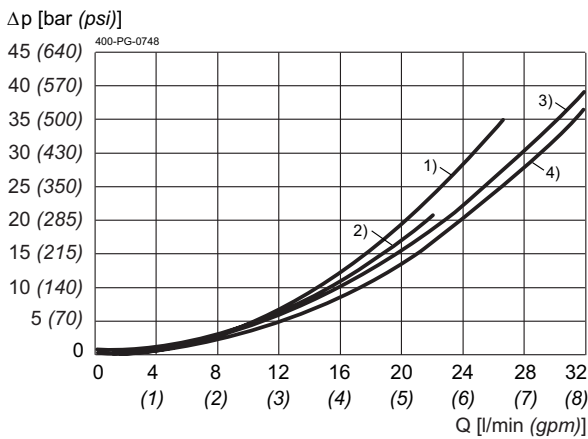

- 1) = 2 → 1
- 2) = 1 → 2
- 3) = 3 → 2
- 4) = 2 → 3

$p = f(Q)$ Performance limit

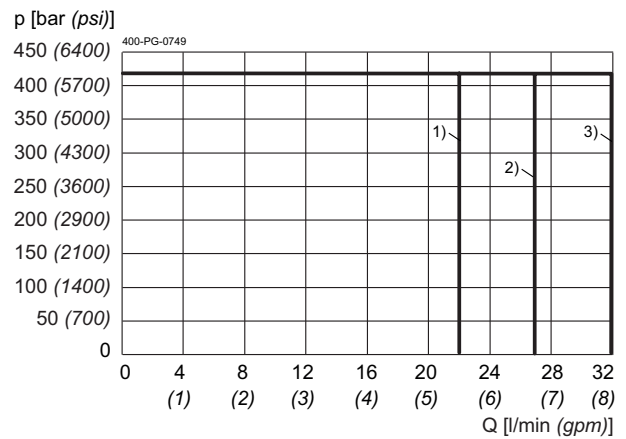

- 1) = 1 → 2
- 2) = 2 → 1
- 3) = 2 → 3; 3 → 2

Dimensions and sectional view

Beispiel für die Masseinheit:
Example for the dimensional units:
0.79 = 0.79 mm millimeter
(.031) = 0.031" inch

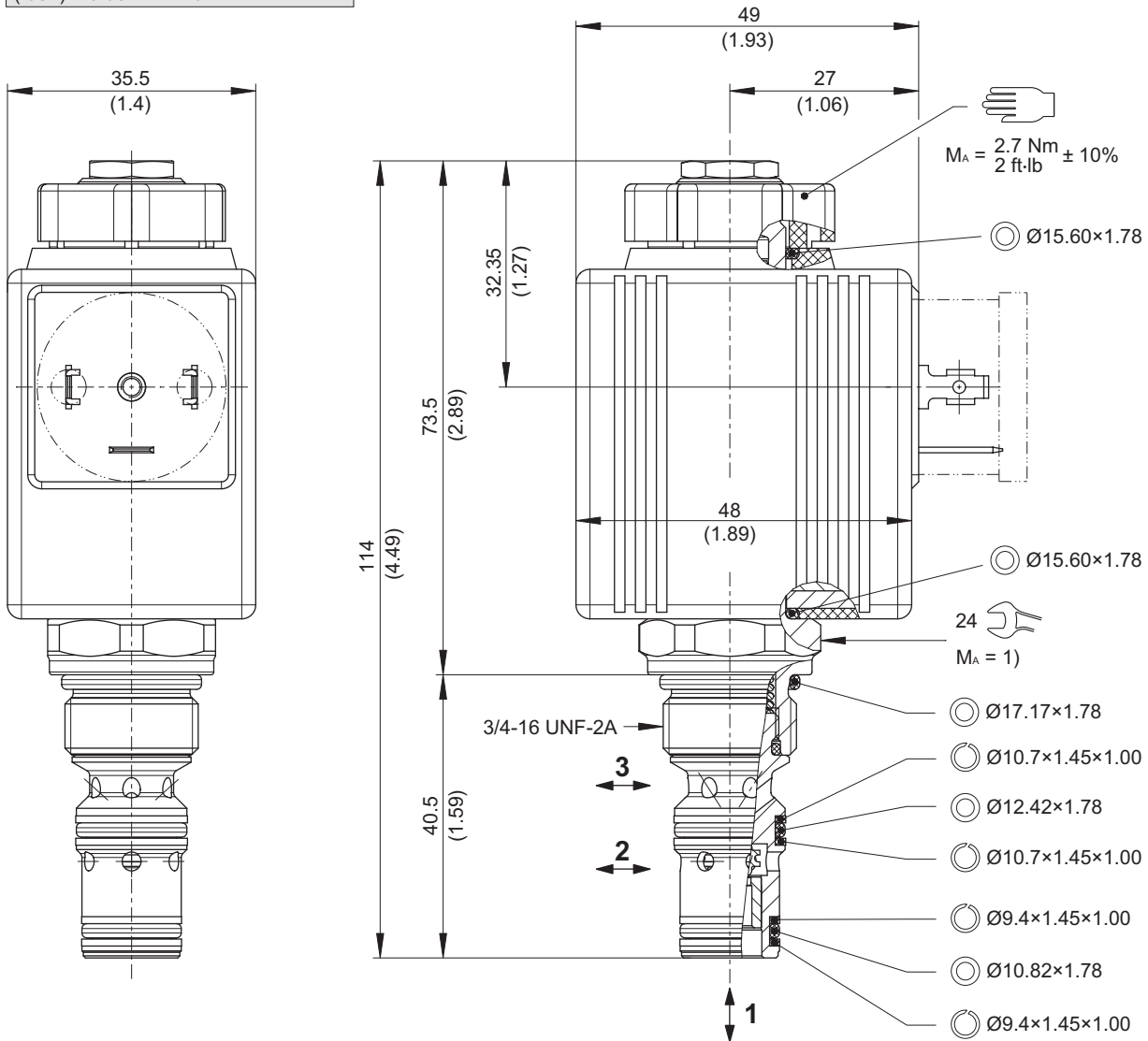

Installation information

i IMPORTANT!
1) When fitting the screw-in cartridge valve, use the specified tightening torque. The value can be found in the chapter "Technical data".

i NOTE!
The seals are not available individually. The seal kit order number can be found in the chapter "Technical data".

! ATTENTION!
Only qualified personnel with mechanical skills may carry out any maintenance work. Generally, the only work that should ever be undertaken is to check, and possibly replace, the seals. When changing seals, oil or grease the new seals thoroughly before fitting them.

Ordering code

	Ex.	W	S	D	P	P	32G	-	5	P	-	-	N	A	1	24	D	G	-	
W	=	directional valve																		
S	=	seat valve shut-off (<i>bidirectional</i>)																		
D	=	direct acting																		
P	=	electrically operated, COIL 38x48/16.1, 19W																		
P	=	high-pressure model, 420 bar																		
32G	=	3-way/2-position, de-energized closed																		
5	=	nominal size 5 / SAE 08																		
P	=	cavity type GP/C0830																		
O	=	without manual override																		
P	=	with manual override																		
S	=	with screwable manual override																		
N	=	NBR (nitril-butadien-rubber / BUNA) seals (standard)																		
V	=	FKM (fluorocarbon rubber / VITON) seals (<i>special seals - please consult BUCHER</i>)																		
A ... Q	=	standard model according to valid data sheet																		
Z ... R	=	special model after consultation																		
1 ... 9	=	technical design no. (<i>omit when ordering</i>)																		
...	=	voltage e.g. 24 (24 V)																		
D	=	current DC																		
G	=	standard plug connection to DIN EN (3-pole, 2 P+E, IP 65)																		
J	=	Junior-Timer radial plug connection (IP 65)																		
JR	=	Junior-Timer radial plug connection (with protection diode, IP65)																		
U	=	Deutsch plug connection radial DT04-2P (IP 67/69K)																		
UR	=	Deutsch plug connection radial DT04-2P (with protection diode, IP 67/69K)																		
blank	=	without mating plug																		
Q	=	with mating plug (only by connection type "G" possible)																		



IMPORTANT!

Minimum order quantity of 500 pcs/year

Related data sheets

Reference	Description
400-P-040011	Form tools
400-P-120212	Solenoid coil 36X48/16.1
400-P-010101	MTTFD Values for Hydraulic Valves
400-P-040422	Cavity GP/C0830
400-P-738581	Threaded port body GGP-38...

info.ch@bucherhydraulics.com

www.bucherhydraulics.com

© 2023 by Bucher Hydraulics AG Frutigen, 3714 Frutigen, Switzerland

All rights reserved.

Data is provided for the purpose of product description only, and must not be construed as warranted characteristics in the legal sense. The information does not relieve users from the duty of conducting their own evaluations and tests. Because the products are subject to continual improvement, we reserve the right to amend the product specifications contained in this catalogue.