

## 4-Way/2-Position Self-Reversing Valve, NG 10

$Q_{\max} = 80 \text{ l/min}$ ,  $p_{\max} = 210 \text{ bar}$

Subplate mounting

Series WOFB-10...

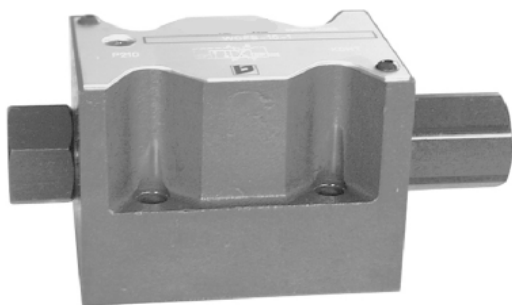

- Automatic, load-independent reversal
- Predefined actuator direction at start-up
- No reversal pressures to set
- Simple construction (only 1 moving part)
- Long service life
- For subplate mounting, Interface NG 10 to ISO 4401-05-04

### 1 Description

The valve automatically reciprocates when connected to a hydraulic cylinder, for example. When the cylinder reaches the end of its stroke, or when the load pressure rises to the relief valve setting, there is no longer any flow through the valve. The cessation of flow causes the valve spool to shuttle to its other end position and consequently the actuator moves in the reverse direction. The reversal process is virtually independent of the load pressure. The process continues as long as the specified minimum flows and pressures are produced by the pump. In order to set the system

pressure limiter, it will be evident that the self-reversing function of this valve must be blocked: See "Setting system relief valve". The valve is designed in such a way that when pressure is connected to the P port the first flow condition is always  $P \Rightarrow B$  and  $A \Rightarrow T$ . This means, for example, that where an unequal area cylinder is used on a machine with strict safety requirements, then the A port of the valve should be connected to the full bore end of the cylinder and the B port to the annulus end (e.g. compactor circuits, where the first cylinder movement must be to retract).

### 2 Symbol

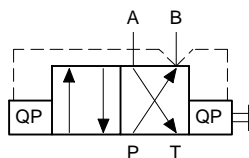

### 3 Technical data

General characteristics	Description, value, unit
Designation	4-way/2-position self-reversing valve
Design	sliding-spool design
Mounting method	subplate mounting
Size	NG 10, interface ISO 4401-05-04
Weight	3.0 kg

Hydraulic characteristics	Description, value, unit
Mounting attitude	unrestricted
Flow direction	see symbols
Maximum operating pressure	60 ... 210 bar, higher pressures on request
Hydraulic fluid	HL and HLP mineral oil to DIN 51 524; for other fluids, please contact BUCHER
Hydraulic fluid temperature range	-20 °C ... +60 °C
Viscosity range	20 ... 200 mm <sup>2</sup> /s (cSt)
Maximum flow rate	80 l/min
Flow rate range	P ⇒ A / A ⇒ T = max. 80 l/min P ⇒ B / B ⇒ T = max. 40 l/min P ⇒ B / B ⇒ T = min. 10 l/min
Cylinder area ratio	recommended $\phi = 1 \dots 1.5$ permitted $\phi = 1 \dots 2$
Cylinder internal leakage at p = 210 bar	max. permissible 0.7 l/min
Surface corrosion protection	all exposed parts with zinc-nickel plating
Minimum fluid cleanliness Cleanliness class to ISO 4406 : 1999	class 20/18/15

## 4 Application example and pressure settings

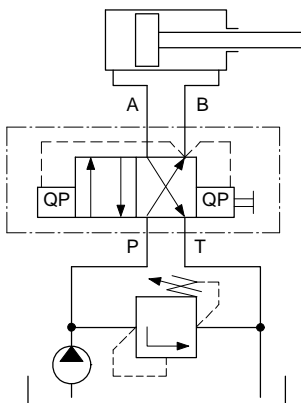

### Applications (e.g.)

- in compactor controls
- in-container compactors
- in slurry scrapers
- in piston-type intensifiers
- for pressure intensifiers

## 5 Performance graphs

measured with oil viscosity 33 mm<sup>2</sup>/s (cSt)

$\Delta p = f(Q)$  Pressure drop-flow rate characteristic

$\Delta p$  [ bar (psi) ]

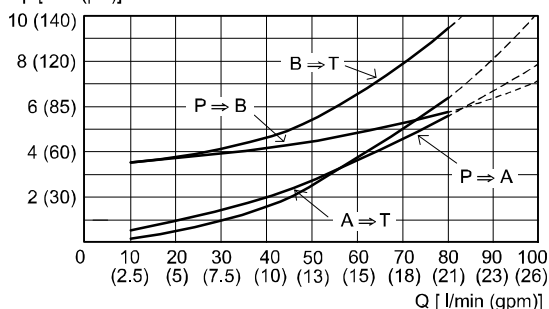

## 6 Dimensions & sectional view

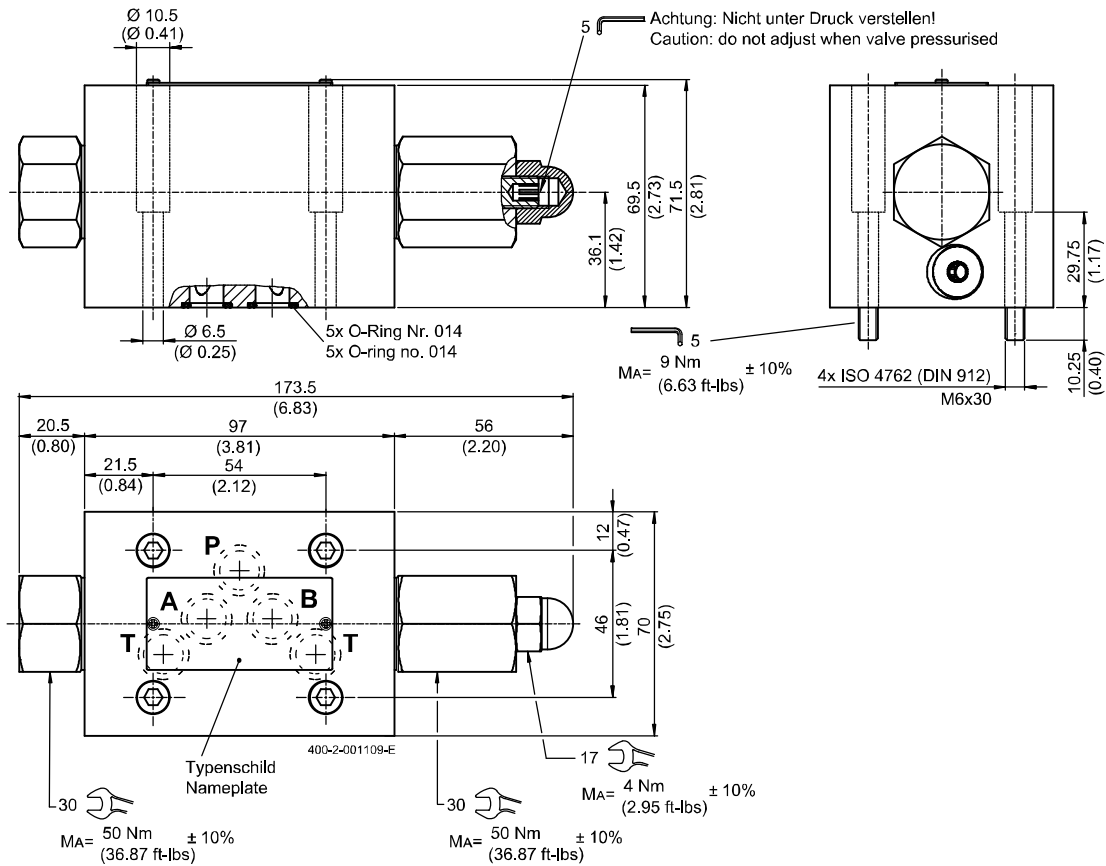

## 7 Setting system relief valve

- Switch off pump, alternatively reduce pressure to minimum (10 bar max.).
- To set the system relief valve, first block the automatic reversal of the valve. Remove the dome nut, turn the offsetting spindle clockwise until it hits its inner end stop. The spool is now clamped P ⇒ B, A ⇒ T.
- Start the pump. Set the required relief pressure.
- Stop the pump.
- Turn the offsetting spindle anticlockwise until it hits its outer end stop, then replace the dome nut.



### ATTENTION!

Never turn the offsetting spindle when the valve is pressurised, as this can cause seal damage. If necessary, switch off the pump.

## 8 Schematic section

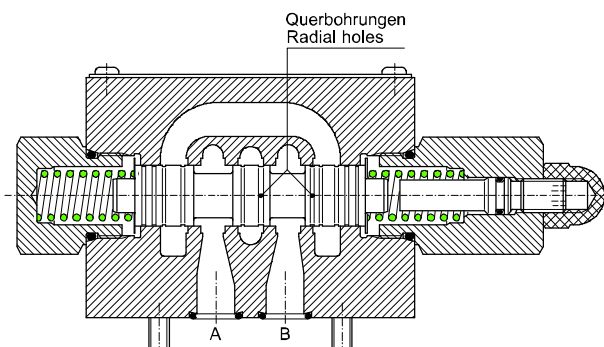

### 9 Safety instructions



**IMPORTANT!:**

When the pump is switched of (e.g. emergency switch in the plant), the valve spool will reset to P⇒ B, A ⇒T (the “Pump Start” position) after 0.5 secs (measured with fluid viscosity 33 cSt). The cylinder, connected as shown in the Application example, is ready to retract..

Deviation from the circuitry shown in the application example, and changes in the fluid viscosity can result in an increase in the minimum required reversal time.

### 10 Installation information



**ATTENTION!**

Maintenance work may only be carried out carefully by qualified personnel. The following must be observed when carrying out maintenance work on the valve (cleaning, seal change, etc.):

- Unscrew and remove dome nut, spring cap and screw plug
- Remove the 2 springs
- Carefully slide out the self-reversing spool
- The self-reversing spool is asymmetric and must not be reinserted the wrong way round, otherwise the normal Pump Start function P ⇒ B and A ⇒ T will be reversed to P ⇒ A and B ⇒ T. The correct spool orientation can be identified by the 2 small radial holes. The spool is factory-inserted so that these 2 holes are above the B port of the hydraulic interface



**IMPORTANT!:** When fitting new seals ensure that they are first well oiled or greased.



**IMPORTANT!:** Before refitting the spring cap the offsetting spindle must be fully retracted into the spring cap allow the spool to oscillate freely.



**IMPORTANT!:** Observe the correct tightening torques for spring cap plug and plastic dome nut.

### 11 Ordering code

Ex. WOF B - 10 \_ - 1

- WOF = 4-way/2-position self-reversing valve
- A ... Q = standard model per current data sheet
- Z ... R = special features by arrangement on request
- 10 = Nominal size 10
- (blank) = NBR (nitril-butadien-rubber / BUNA) seals (standard)
- V = FKM (fluorocarbon rubber / VITON) seals  
*(special seals - please consult BUCHER)*
- 1 ... 9 = technical design no. (omit when ordering)

### 12 Related data sheets

Reference	Description
400-P-050101	Interface NG 10 to ISO 4401-05-04

info.ch@bucherhydraulics.com

www.bucherhydraulics.com

© 2023 by Bucher Hydraulics AG Frutigen, CH-3714 Frutigen

All rights reserved.

Data is provided for the purpose of product description only, and must not be construed as warranted characteristics in the legal sense. The information does not relieve users from the duty of conducting their own evaluations and tests. Because the products are subject to continual improvement, we reserve the right to amend the product specifications contained in this catalogue.

Classification: 430.300.300.305.305