

# Leak-Free Pipe Rupture Valve for Excavators SAE 1½"

$Q_{\max} = 1000 \text{ l/min [265 gpm]}$ ,  $p_{\max} = 420 \text{ bar [6000 psi]}$   
hydraulic proportional two-stage seat valve, flat design  
Series ESV 32-B-F...

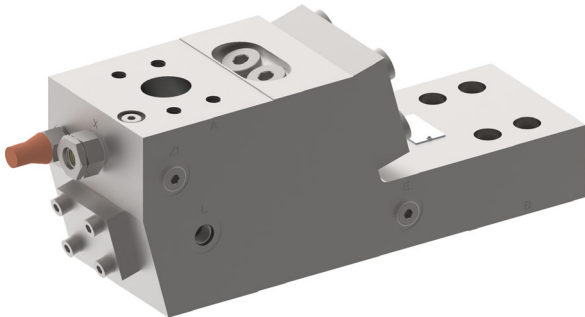

- Fulfills safety requirements in accordance with ISO 8643 and EN 474
- Leak-free load holding
- Guaranteed closing force for the load-control assembly → reliable shut-off even with a broken spring
- No impact, or only very low impact on the existing hydraulic system → easy to retrofit
- Satisfies exacting demands on corrosion protection thanks to zinc-nickel coating
- Pressure relief is independent of return-line pressure
- Low-noise operation thanks to specially shaped control grooves

## 1 Description

The excavator pipe-rupture valve is used wherever so required by the standards ISO 8643 and EN 474 for excavators with a lifting device (e.g. a load hook on the bucket). The actuators concerned are the lift cylinder, the stick cylinder and the adjusting cylinder.

It is also possible to envisage other machine applications in which a pipe rupture on the actuators could produce dangerous situations (e.g. machines for materials handling and demolition). The excavator pipe rupture valve, type ESV (Excavator Safety Valve), prevents uncontrolled lowering of the actuator in the event of a pipe or hose rupture. In addition, the ESV valve holds the actuator in its position when the main valve is centered. The valve includes a two-stage, secondary pressure-relief function, which protects the actuator against overload. The pressure relief is independent of any back pressure in port A. For main spools with closed

center position and secondary valve connected in series, no pressure summing occurs. There is no need for a large-bore, external tank return line.

Thanks to its load-independent, two-stage opening principle, variations in load pressure - even right up to the maximum - have no effect on the fine control characteristics and the hydraulic performance of the equipment. The design of the valve means that it can be operated by very small lowering pressures. This means that excavators with and without a materials handling function can be equipped with the same basic hydraulic system (the machine's work cycles remain the same).

The inlet and actuator ports on the ESV are standard SAE flanged ports, and the valve can therefore be retrofitted to existing equipment without any difficulty.

## 2 Symbol

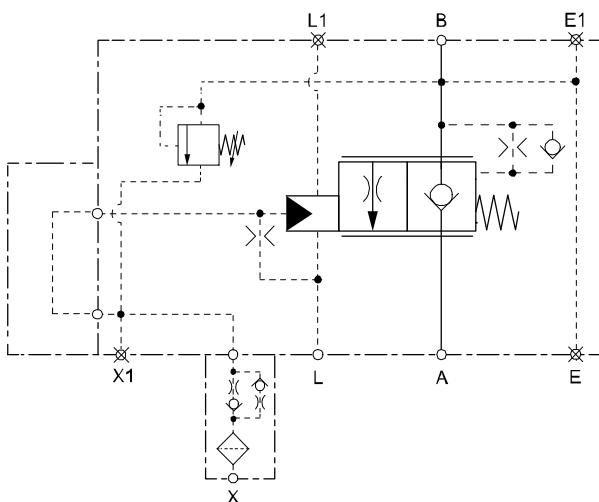

### 3 Technical data

| General characteristics      |              | Description, value, unit  |   |
|------------------------------|--------------|---|---|
| Designation                  |              | leak-free pipe rupture valve for excavators   |   |
| Design                       |              | hydraulic proportional two-stage seat valve, flat design  |   |
| Size                         |              | size 32, SAE 1½", 6000 psi  |   |
| Mounting method              |              | flange mounting<br>(4x hex. socket-head cap screws<br>M16x60<br>ISO 4762 (DIN 912), – grade 12.9) |   |
| Main ports                   | A            | SAE 1½", 6000 psi   | ISO 6162-2 DN38 M16<br>(SAE J518 Code 62-24, M16x2) |
| Main port                    | B            | SAE 1½", 6000 psi   | ISO 6162-2 DN38 M16<br>(SAE J518 Code 62-24, M16x2) |
| Control / drain ports        | X, X1, L, L1 | 9/16-18 UNF-2B  | ISO 11926-1 (SAE-6, SAE J1926-1)                    |
| Compensation ports           | E, E1        | 9/16-18 UNF-2B  | ISO 11926-1 (SAE-6, SAE J1926-1)                    |
| Weight                       |              | ca. 27.0 kg   | [ca. 59.52 lbs]                                     |
| Mounting attitude            |              | unrestricted  |   |
| Ambient temperature range    |              | - 25 °C ... +100 °C<br>(others on application)  | [-13 °F ... +212 °F]                                |
| Surface corrosion protection |              | zinc-nickel coating<br>Mounting screws zinc-flake coated<br>(e.g. with Geomet® finish)            |   |

| Hydraulic characteristics  |  | Description, value, unit  |  |
|--|--|---|--|
| Maximum operating pressure                                       |  | 420 bar   | [6000 psi]   |
| Maximum pressure at the flow- or return port A                   |  | 420 bar   | [6000 psi]   |
| Maximum pressure at the actuator- / load port B                  |  | 420 bar   | [6000 psi]   |
| Maximum pressure at the pilot port X                             |  | 420 bar   | [6000 psi]   |
| Maximum flow rate  |  | 1000 l/min  | [265 gpm]  |
| Flow direction   |  | A → B, free flow through check valve<br>B → A, controlled flow            |  |
| Operator type  |  | hydraulic proportional  |  |
| Pilot pressure range   |  | opening pressure<br>full opening  | min. 4 bar / max. 9 bar (can be chosen)<br>opening pressure + 14 bar +<br>drain-oil pressure |
| Opening pilot ratio  |  | 113:1   |  |
| Secondary pressure relief valve SVX                              |  | 200...420 bar<br>setting is factory-sealed<br>(lower settings on request) | [2900...6000 psi]  |
| Factory setting tolerance of the secondary pressure relief valve |  | 0 ... + 14.0 bar  | [0 ... + 200 psi]  |

| Hydraulic characteristics   |     | Description, value, unit   |                      |
|---|-----|--|----------------------|
| Hydraulic fluid   |     | HL and HLP mineral oil to DIN 51 524;<br>for other fluids, please contact BUCHER   |                      |
| Hydraulic fluid temperature range                                 |     | - 20 °C ... + 80 °C  | [-4 °F ... +176 °F]  |
| Temperature rating of seals                                       | NBR | - 25 °C ... + 100 °C   | [-13 °F ... +212 °F] |
|   | FKM | - 20 °C ... + 200 °C   | [-4 °F ... +392 °F]  |
|   | MIL | - 55 °C ... + 80 °C  | [-67 °F ... +176 °F] |
| Viscosity range   |     | 2.8...1500 mm <sup>2</sup> /s (cSt), recommended 10...380 mm <sup>2</sup> /s (cSt) |                      |
| Minimum fluid cleanliness<br>Cleanliness class to ISO 4406 : 1999 |     | class 20/17/14   |                      |

## 4 Construction and function

The functions of the control assembly are subdivided into the following positions:

### 4.1 Neutral position

The load pressure and the compression spring act on the control spool in the closing direction. The valve is closed with no leakage.

### 4.2 Lifting (flow direction from A → B)

The pump pressure at port A opens the valve against the "light" compression spring and the load. The pilot spool and control spool move together in the opening direction. Oil flows from A → B and the valve functions as a check valve.

### 4.3 Lowering (flow direction from B → A)

The pilot pressure at port X acts on the pilot piston and against the control springs. The pilot spool opens. As a result, the load pressure B is discharged to port A via the metering grooves in the pilot spool. The progressive characteristic of the pre-opening phase ensures that lowering begins smoothly and without jerks.

If the pilot pressure at port X is increased, the pilot spool opens further. The change in the pressure conditions at the control spool means that it follows the pilot spool in the opening direction. The oil flows from B → A.

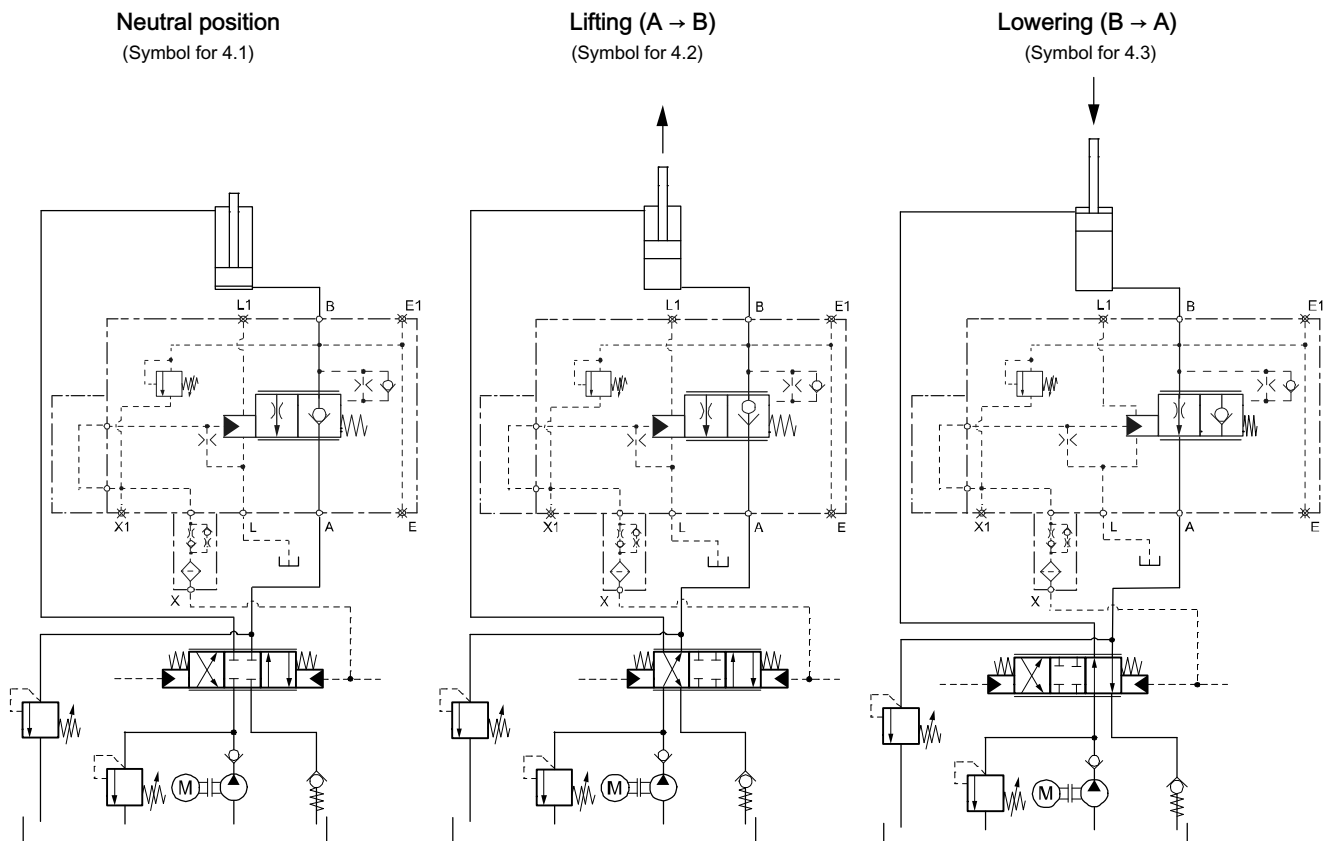

## 4.4 Types of pilot control

General:

The series-connection of the orifices allows the opening time, the closing time, the start of opening, and the full extent of opening to be matched to the requirements of the application.

## 4.5 Secondary pressure relief valve (SVX)

To protect the actuator from overload, a two-stage secondary pressure relief valve is available. Protection is provided up to the full nominal flow rate.

Two-stage secondary pressure relief valve version:  
SVX (B → L/A)

The two-stage secondary pressure relief valve (SVX) is set at a flow rate of approx. 0.3 l/min. When the pressure setting is reached, the SVX opens with a small pilot flow from B → X/L.

The pilot flow builds up pressure at the pilot piston, which opens the pilot spool and the control spool (connection B → A), as in the case of lowering (see section ⇒ 4.6). If the load pressure is increased, the control spool opens further and more oil drains. The load pressure is subject to a maximum limit up to the full nominal flow rate.



**IMPORTANT!** If the security seals or other security elements are removed, all Bucher Hydraulics' liabilities become null and void.



**IMPORTANT!** With open-center directional valves, make sure that the valve has an adequate flow rating.



**IMPORTANT!** With body variant L, the spring chamber in the pressure relief valve is drained to tank, so the return-line pressure does not affect the pressure setting.



**ATTENTION!** In the case of a tank-line preload, the pressure is additive 1:1 to the pressure setting!

Circuit example for SVX (B → L/A), not influenced by return-line pressure, for directional valves with open-centre spool

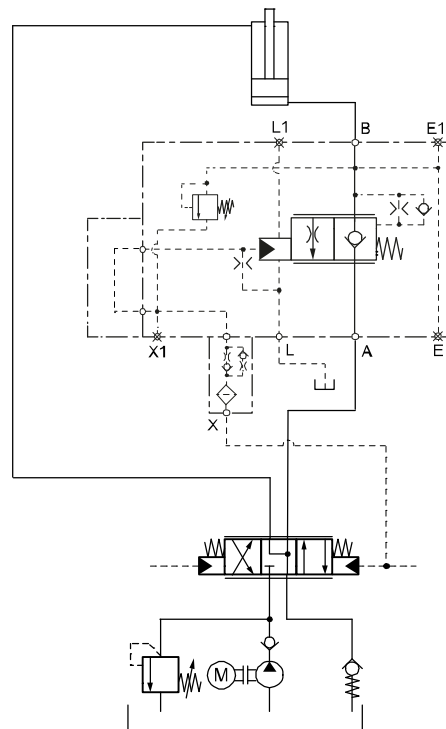

## 5 Performance graphs

measured with oil viscosity 33 mm<sup>2</sup>/s (cSt)

$\Delta p = f(Q)$  Pressure drop - Flow rate characteristic

Lifting A → B

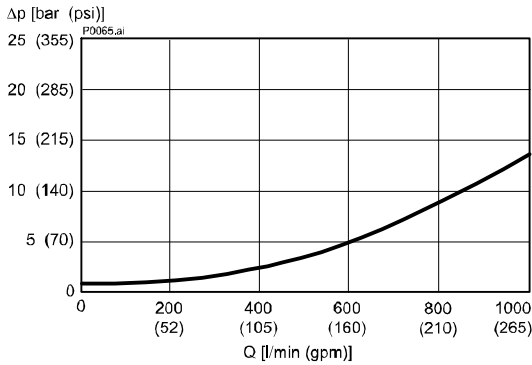

$Q = f(p_X)$  Pressure - Flow rate characteristic  
at 33 bar load pressure

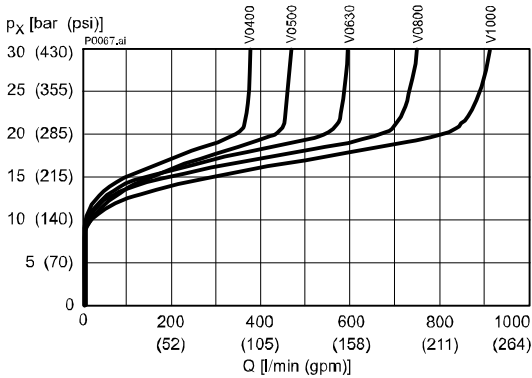

$\Delta p = f(Q)$  Pressure drop - Flow rate characteristic  
Lowering B → A

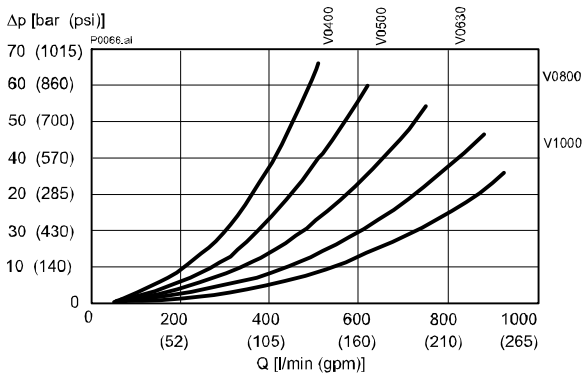

$p = f(Q)$  Pressure - Flow rate characteristic

Secondary pressure relief valve SVX

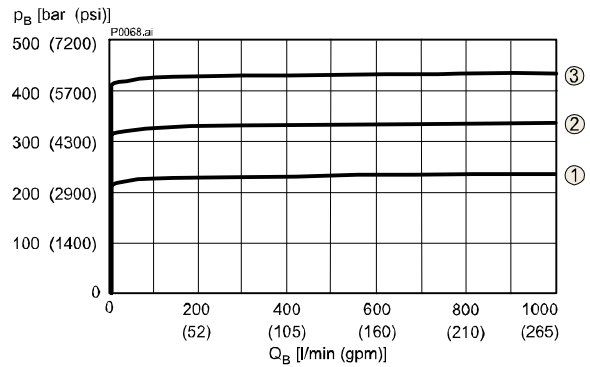

|   |                            |
|---|----------------------------|
| 1 | Setting 220 bar (3100 psi) |
| 2 | Setting 320 bar (4600 psi) |
| 3 | Setting 420 bar (6000 psi) |

$p = f(Q)$  Pressure - Flow rate characteristic

Section of the SVX characteristic

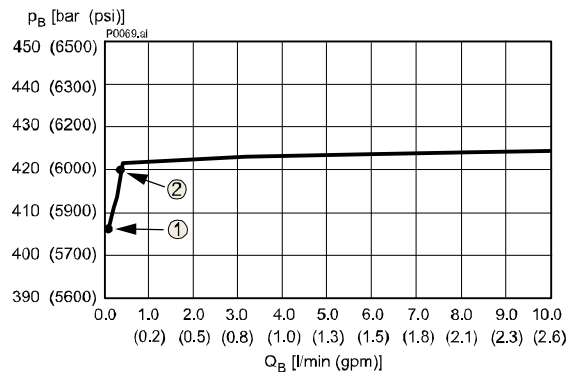

|   |              |
|---|--------------|
| 1 | First drop   |
| 2 | Set pressure |

Due to the way the SVX works, a small amount is tapped at port B before the set pressure is reached.

This is illustrated in the section of the SVX characteristic curve up to a volume flow of 10 l/min. This section applies particularly to an inlet-orifice (ZD)  $\varnothing$  0.8 mm and a bypass-orifice (BY)  $\varnothing$  0.4 mm and shows the pre-opening and the transition to the flat range of the characteristic curve.

First drop (1) designates the point at which the pressure relief valve starts to leak the first drop.



**IMPORTANT!** peak pressures: max. 50 bar (measured at a rate of pressure rise of 3000 bar)

## 6 Dimensions & sectional view

Mit Druckbegrenzungsventil (SVX)  
With pressure relief valve (SVX)

Beispiel für die Masseinheit:  
Example for the dimensional units:

0.79 = 0.79 mm millimeter  
[.031] = 0.031 " inch

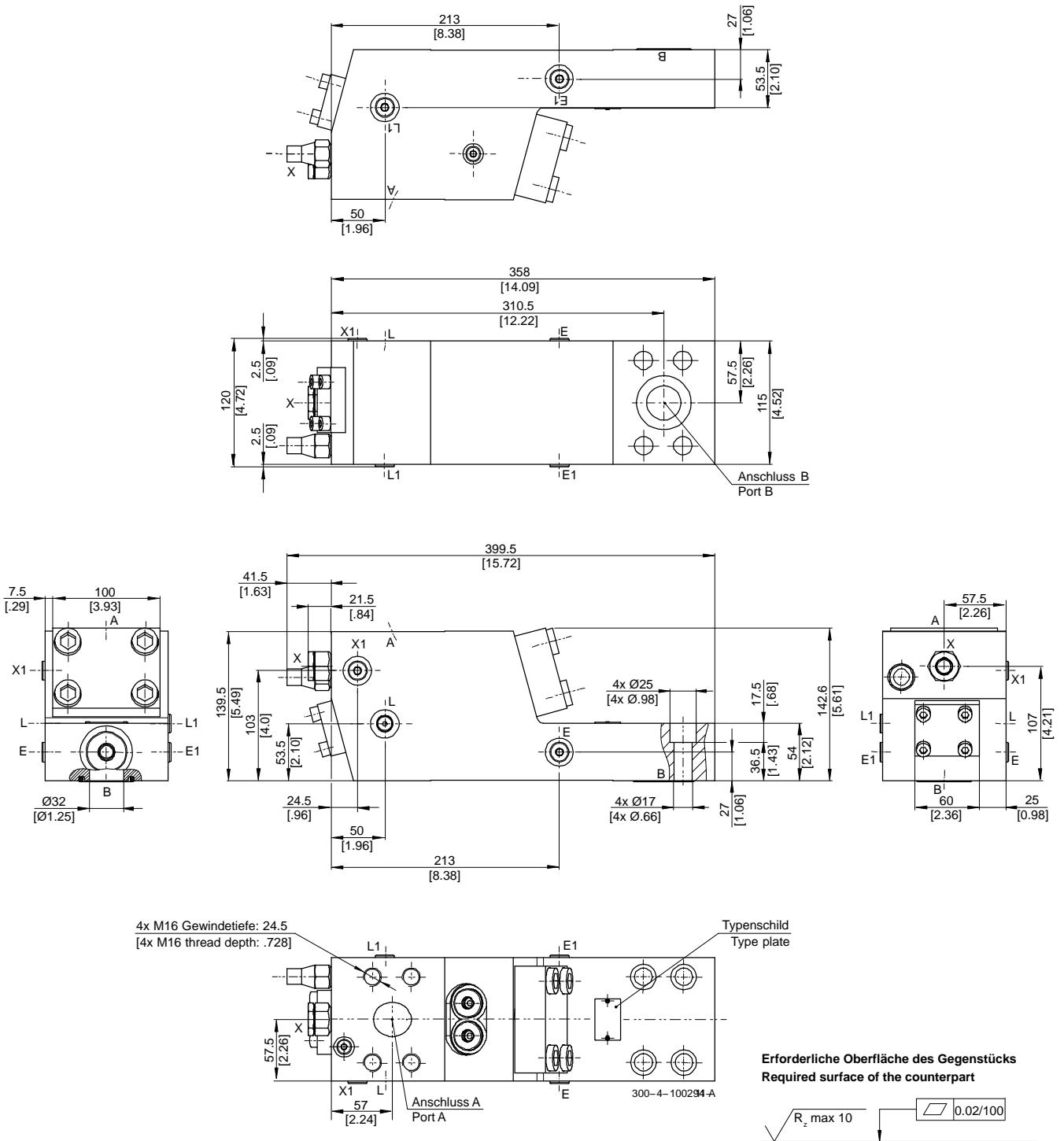

## 7 Safety instructions

**IMPORTANT!:**

Designing load-control valves requires specialist technical knowledge and product knowledge. Safety applications must be verified by adequate tests to ensure safety in actual use.

### 7.1 Assembly / disassembly

**IMPORTANT!:**

The valve may only be used for its intended purpose within its nominal rating. If you plan to use it outside the nominal rating, you must contact the valve manufacturer. The ultimate responsibility for safety in the installation and use rests with the end-machine manufacturer of the mobile application.

**IMPORTANT!:**

The port threads conform to DIN 3852 T1. Use screws to DIN 912, grade 12.9, to mount the valve. Tightening torques as per the manufacturer's instructions.

**IMPORTANT!:**

Protect seals and flange faces from damage. The mating flange face must be of the quality specified in the data sheet! Pay attention to the port designations.

**IMPORTANT!:**

Seal kit with the external seals is available on application.

8 Application examples

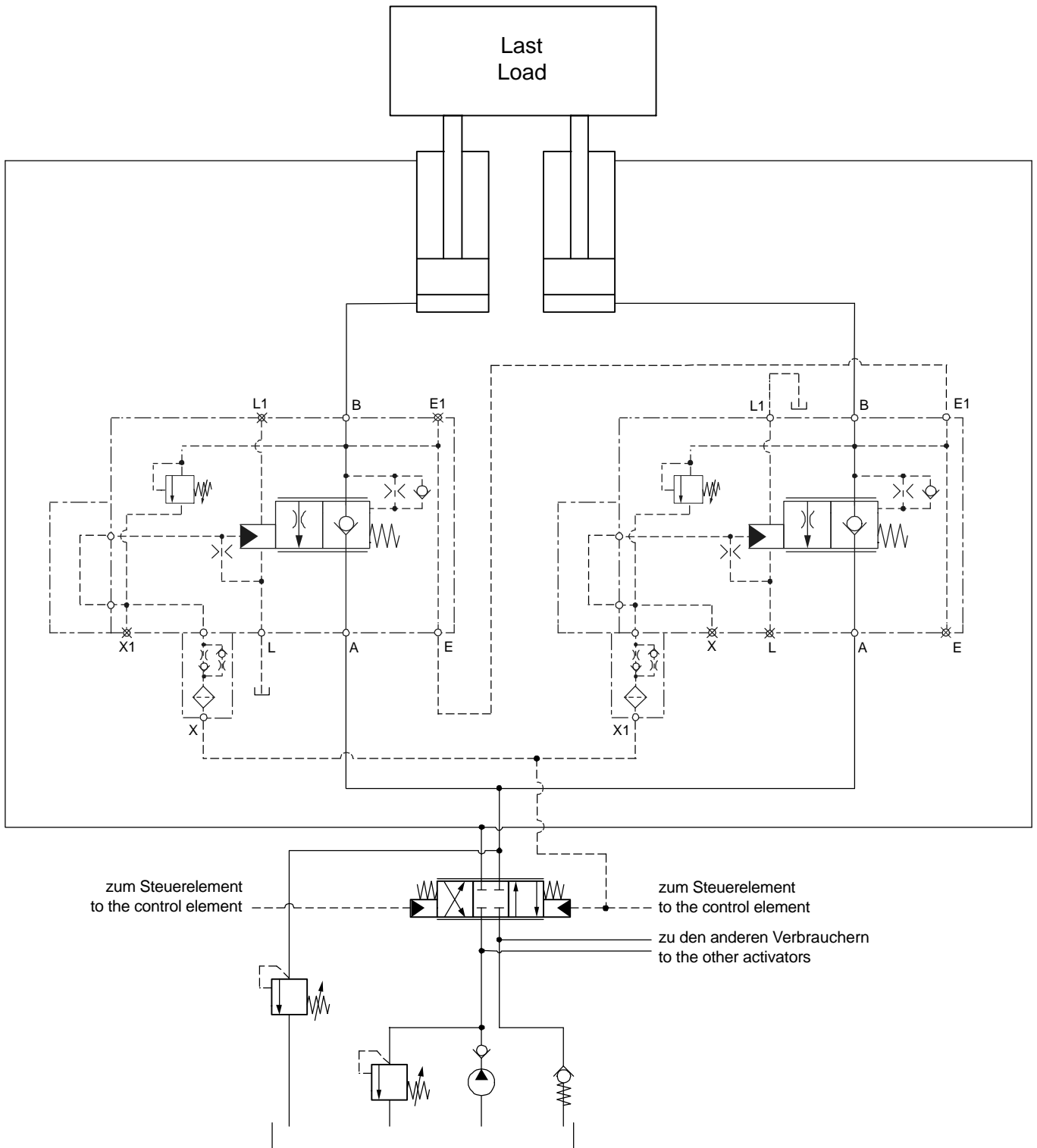



## 9 Ordering code

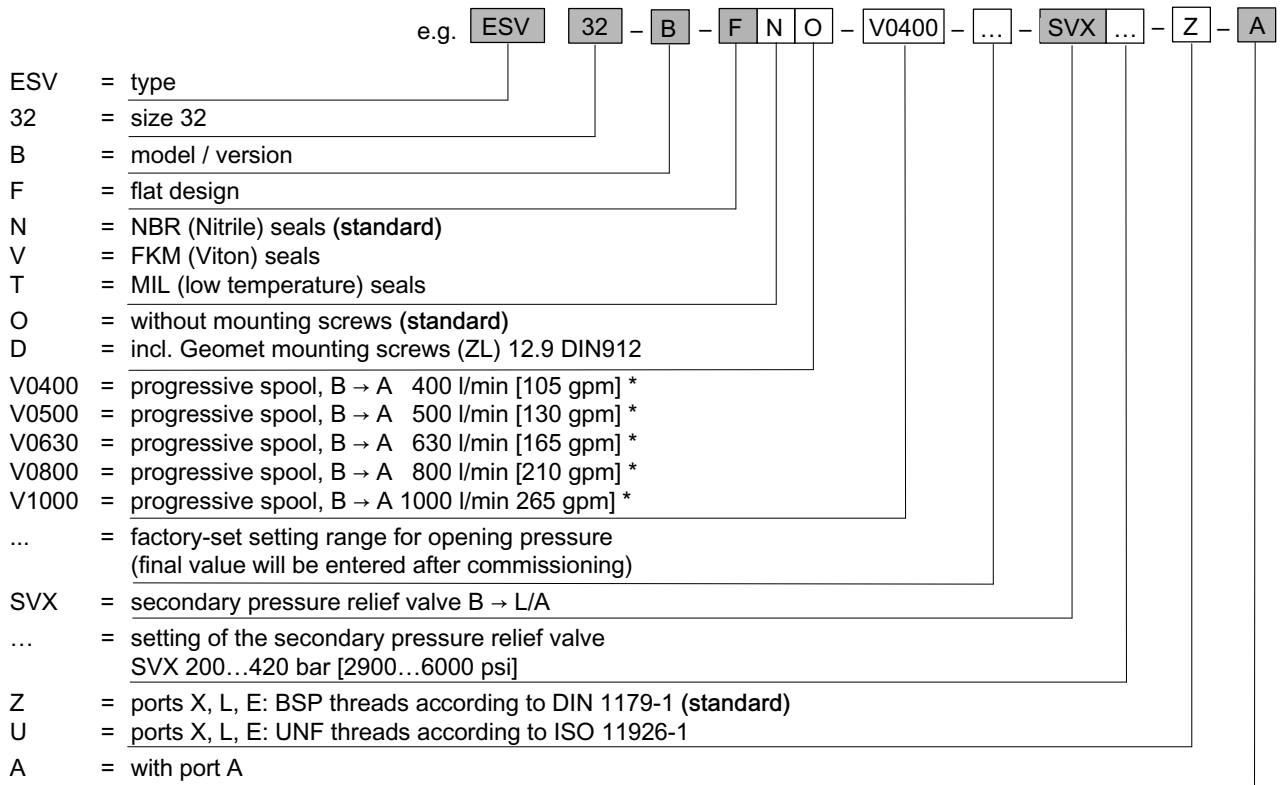

\*) measured at 33 bar [478 psi]  $\Delta p$  from B → A.



**IMPORTANT!:**

Designing load-control valves requires specialist technical knowledge and product knowledge.  
Safety applications must be verified by adequate tests to ensure safety in actual use.

## 10 Related data sheets

| Reference     | Description  |
|---------------|--|
| 300-D-9050103 | Technical design sheet for CINDY load-control valves in motor applications |



**IMPORTANT!:**

Additional documentation and 3D models (.stp or .igs format) can be downloaded from [www.bucherhydraulics.com](http://www.bucherhydraulics.com) (LOGintern area; registration is necessary)

We also offer customised solutions. Please talk to our sales team.