

Check valve Pilot operated dual check

$Q_{\max} = 70 \text{ l/min}$, $p_{\max} = 350 \text{ bar}$

hydraulic operation, pilot operated, poppet type

Type series: DERV 8-...



- Screw-in cartridge valve
- All external parts with zinc-nickel coating according to DIN EN ISO 19598
- Two-stage principle (decompression / main opening)
- Load pressure closing cone poppet valve
- Seat tight shut-off
- Compact construction
- Hardened, polished seat section and cone
- Prevents creep of hydraulically clamped actuators

Description

The double pilot-operated check valves, series DERV 8-..., are size 8, two stage and high performance screw-in valves with an M30×1,5 mounting thread. They are designed on the poppet/seat principle and the A1 to A and B1 to B flow paths are therefore virtually leak-free. The check function can be overridden by applying a suitable pressure on the other side. In the A to A1 and B to B1 directions, flow can pass freely th-

rough the screw-in valves (opening pressure = 3.0 bar). All external parts of the screw-in valves are zinc-nickel plated and are thus suitable for use in the harshest operating environments. These screw-in valves are predominantly used in certain mobile and industrial applications to prevent creep movements of the hydraulically clamped actuators (e.g. cylinders) and to maintain the precise position.

Symbol

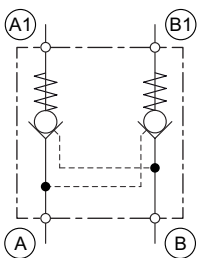

Technical Data

General Characteristics	Description, value, unit
Function group	Check valve
Function	Pilot operated dual check
Design	Screw-in cartridge valve
Controls	hydraulic operation
Characteristic	pilot operated, poppet type
Construction size	size 8
Thread size	M30×1,5
Mounting attitude	unrestricted
Weight	0.45 kg
Tightening torque steel	200 Nm
Tightening torque tolerance	± 10 %
Minimum ambient temperature	- 25 °C
Maximum ambient temperature	+ 100 °C
Surface protection	All external parts with zinc-nickel coating according to DIN EN ISO 19598
Available seal types	several seal types available, see ordering code
Seal kit order number	NBR: 3000308277 / FKM: 3000308278 / MIL: 3000308279

Hydraulic Characteristics	Description, value, unit
Maximum operating pressure	350 bar
Restriction of the operating pressure	max. static pressure: 500 bar
Maximum flow rate	70 l/min
Flow direction	see symbol
Hydraulic fluid	HL and HLP mineral oil according to DIN 51 524; other fluids on request!
Minimum fluid temperature	- 20 °C
Maximum fluid temperature	+ 80 °C
Viscosity range	2.8 ... 1500 mm ² /s (cSt)
Recommended viscosity range	10 ... 380 mm ² /s (cSt)
Minimum fluid cleanliness (cleanliness class according to ISO 4406:1999)	class 20/18/15
Effective hydraulic pilot ratio (p.o. check valve)	1:18
Opening pressure	3 bar
Definition of cracking pressure for check valve	(load pressure ÷ 18) + 3 bar

NOTE!

For other values please contact Bucher Hydraulics.

Performance graphs

measured with oil viscosity 33.0 mm²/s (cSt)

$\Delta p = f(Q)$ Pressure drop-flow rate characteristic

Δp [bar (psi)]

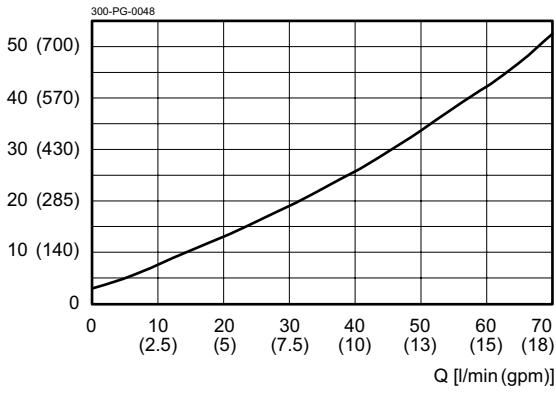

A to A1 and B to B1

$p = f(Q)$ Pressure-flow rate

p [bar (psi)]

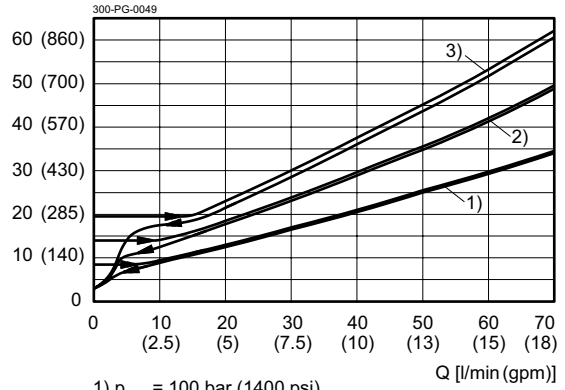

- 1) $p_{Load} = 100$ bar (1400 psi)
- 2) $p_{Load} = 200$ bar (2900 psi)
- 3) $p_{Load} = 300$ bar (4300 psi)

A1 to A and B1 to B

Dimensions and sectional view

Beispiel für die Masseinheit:
Example for the dimensional units:
 0.79 = 0.79 mm millimeter
 (.031) = 0.031" inch

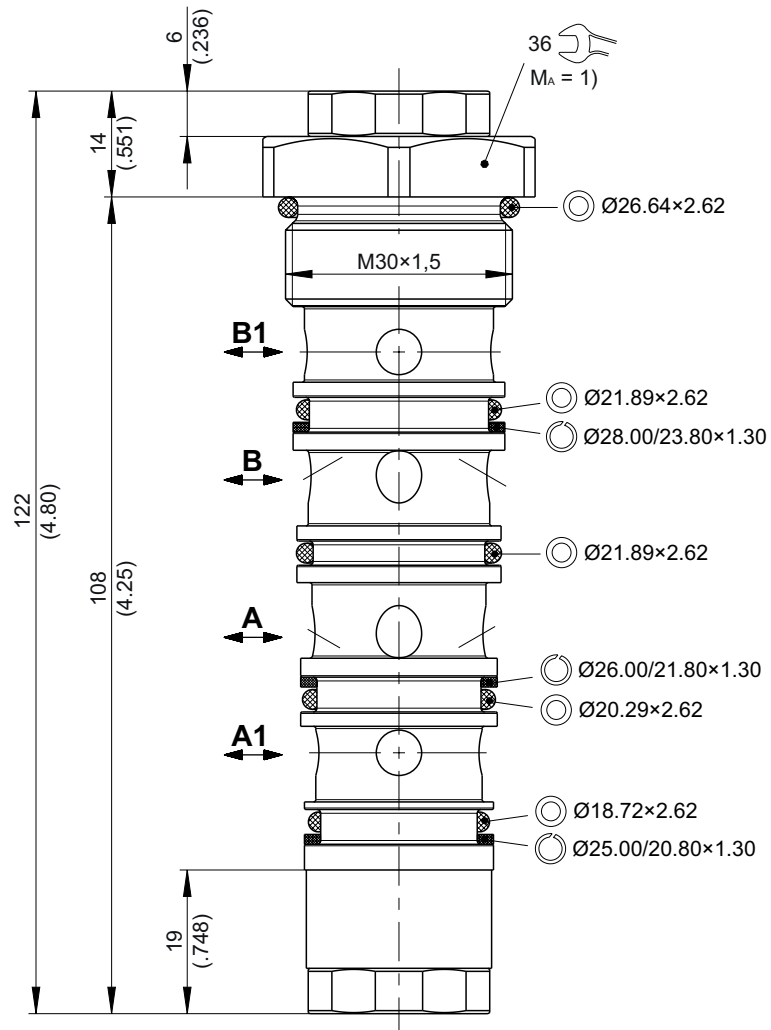

Installation information

i NOTE!
 1) When fitting the screw-in cartridge valve, use the specified tightening torque. The value can be found in the chapter "Technical data".

i NOTE!
 The seals are not available individually. The seal kit order number can be found in the chapter "Technical data".

! ATTENTION!
 Only qualified personnel with mechanical skills may carry out any maintenance work. Generally, the only work that should ever be undertaken is to check, and possibly replace, the seals. When changing seals, oil or grease the new seals thoroughly before fitting them.

Cavity

Beispiel für die Masseinheit:
Example for the dimensional units:
0.79 = 0.79 mm millimeter

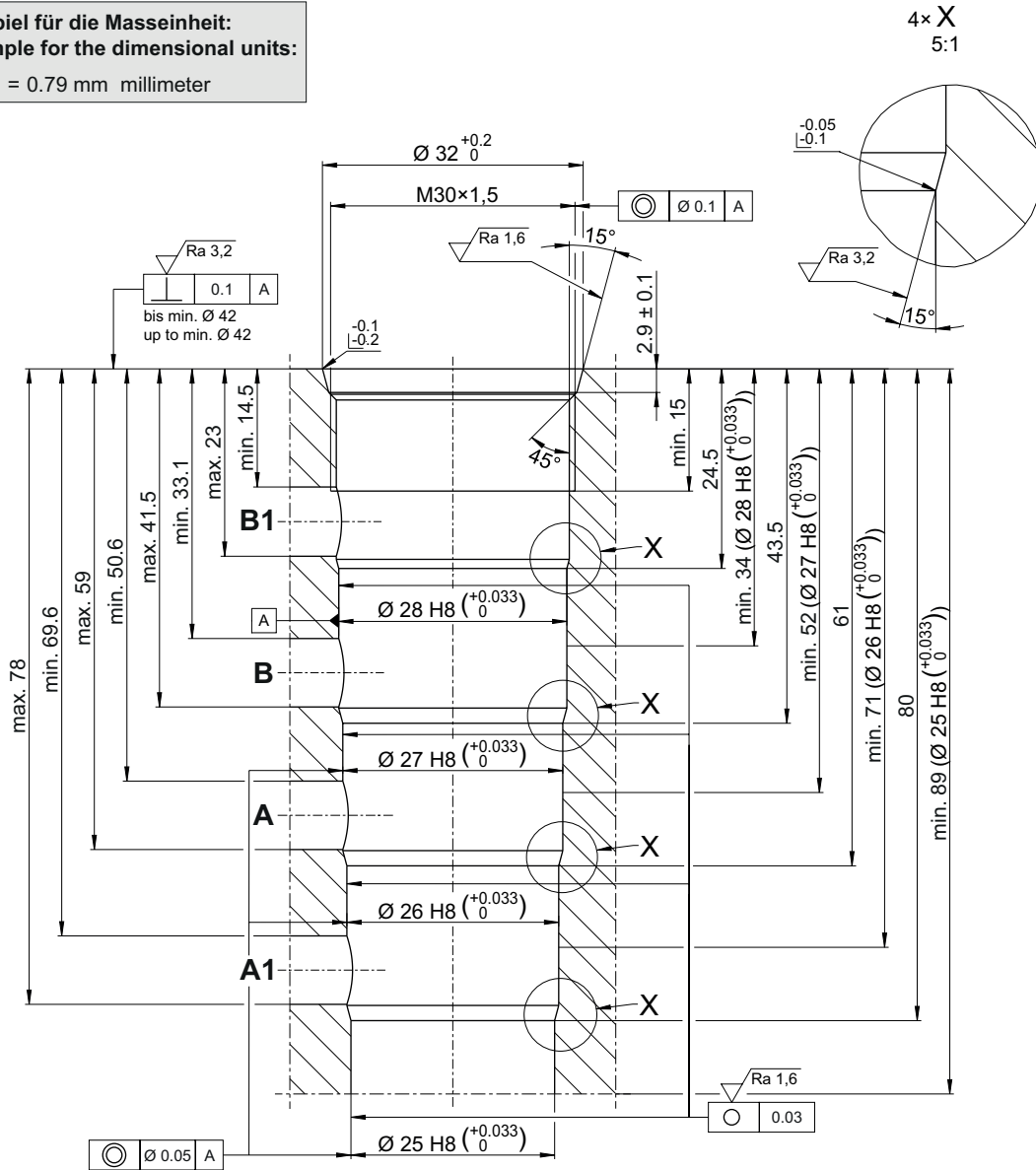

HINWEIS!
NOTE!

Empfohlene Anschlussbohrungen:
Recommended connection bores: A, A1, B, B1: Ø 8

Toleranzen nach: DIN ISO 2768-mK
Tolerances according to:

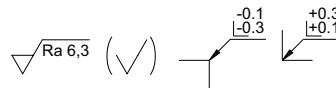

NOTE!

You must maintain the specified positional and diametral tolerances. To ensure trouble-free operation of the screw-in cartridges, we strongly recommend that pilot drilling, boring, reaming and cavity thread-cutting are always performed in one setup.

Ordering code

Ex. DERV - 8 - N

DERV = double pilot operated cartridge check valve

8 = size 8

N = NBR (nitril-butadien-rubber / BUNA) seals (*standard*)

V = FKM (fluorocarbon rubber / VITON) seals

T = MIL (low temperature) seals
(*special seals - please consult BUCHER*)