

Check valve

Spring loaded check

$Q_{\max} = 22 \text{ l/min}$, $p_{\max} = 350 \text{ bar}$

ball type

Type series: RVVE-G-06



- Screw-in cartridge valve
- Compact construction
- High pressure rating
- Very small pressure rise
- High opening pressures
- Usable as preload valve

Description

The RVVE series check valve is characterized by very high opening pressures and very small pressure rise. This is reflected in the flat performance graph. The valve can be used as a preload valve. The spring-loaded spherical poppet-type check valve is very robust, extremely leak-proof and insensitive to contamination.

Valve seat, poppet and body are hardened. The properties of the sealing faces have been enhanced by precision mechanical processing. The valves prevent flow in the screw-in direction (B to A) and open in the opposite direction. The valve is available in nominal sizes 04, 06, 08, 10, 16, 25, 32 and 40.

Symbol



Technical Data

General Characteristics	Description, value, unit
Function group	Check valve
Function	Spring loaded check
Design	Screw-in cartridge valve
Characteristic	ball type
Thread size	G 1/4"
Mounting attitude	unrestricted
Weight	0,001 kg
Tightening torque steel	7 Nm

Hydraulic Characteristics	Description, value, unit
Maximum operating pressure	350 bar
Maximum flow rate	22 l/min
Nominal flow rate	15 l/min
Flow direction	prevent flow in screw-in direction
Hydraulic fluid	HL and HLP mineral oil according to DIN 51 524; other fluids on request!
Minimum fluid temperature	- 30 °C
Maximum fluid temperature	+ 80 °C
Viscosity range	10 ... 500 mm ² /s (cSt)
Minimum fluid cleanliness (cleanliness class according to ISO 4406:1999)	class 20/18/15
Opening pressure	4 / 6 / 8 / 10 / 12 bar

i NOTE!
For other values please contact Bucher Hydraulics.

Performance graphs

measured with oil viscosity 33.0 mm²/s (cSt)

$\Delta p = f(Q)$ Pressure drop-flow rate characteristic

Δp [bar]

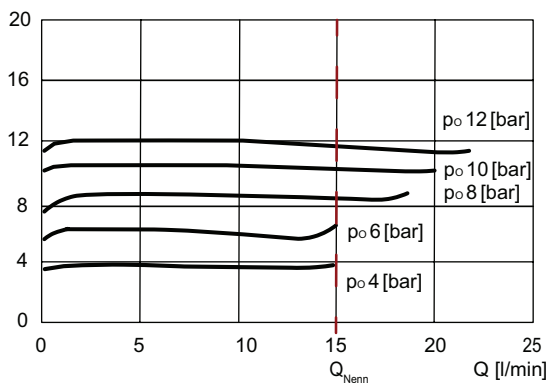

Dimensions and sectional view

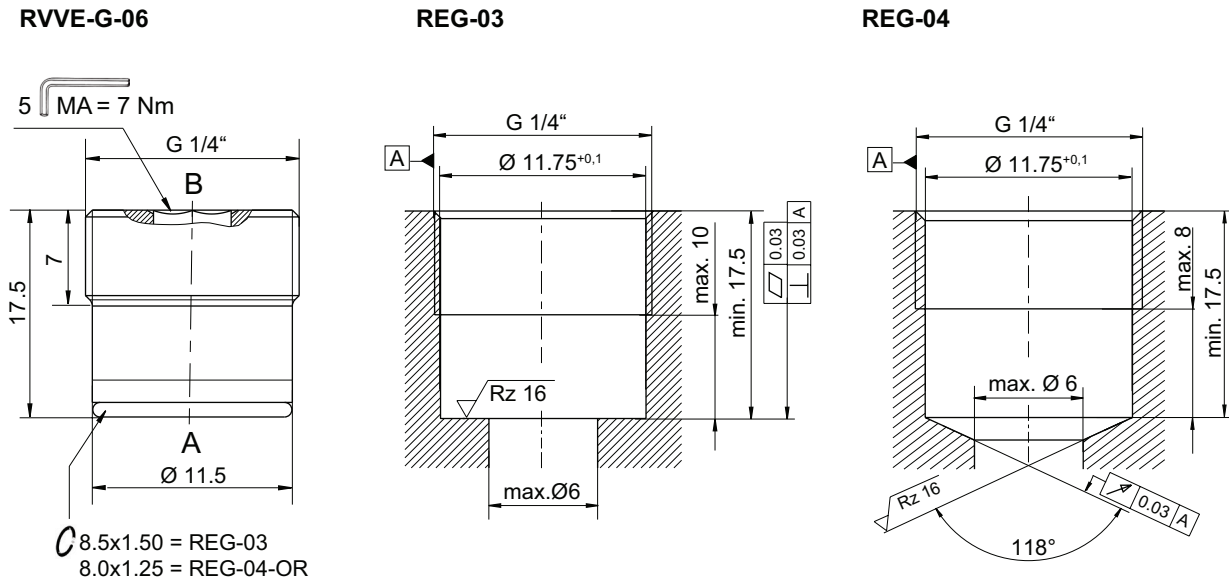

RVVE-G-06 = check valve / screw-in cartridge valve

REG-03 / REG-04 = dimension of the cavity for screw-in cartridge RVVE-G-06

Installation information



IMPORTANT!

When fitting the screw-in cartridge valve, use the specified tightening torque. The value can be found in the chapter technical data. Orifices or nozzles are to be placed after the check valve. If this is not possible, a right-angled bore must be designated between the check valve and the nozzle. (see data sheet 170-P-059000). Suitable fitting tools are available at Bucher Hydraulics (see data sheet 170-P-051600).



ATTENTION!

When fitting the valve, make sure that it is firmly seated on the sealing surface and that it is not deformed by the use of excessive force.

Application Notes



NOTE!

The maximum operating pressure must not be exceeded even when pressure peaks occur. In applications such as accumulator circuits, where sudden pressure can be applied to the valve in the free-flow direction, ensure that the specified flow ratings are not exceeded. Buyers bear the sole responsibility for ensuring that the valve is suitable for their applications and must be substantiated by trials or testing, if necessary.



ATTENTION!

The valves are only suitable for pressure relief in the opening direction to a limited extent. (if necessary, please consult Bucher Hydraulics).

Ordering code

RVVE - G - 06 - 6 - - OR118

RVVE = Preload check valve, screw-in type, spherical poppet design

G = Whitworth pipe thread G1/4"

06 = Nominal size 06, Q_{nominal} 15 l/min

4 = Opening pressure 4 bar

6 = Opening pressure 6 bar

8 = Opening pressure 8 bar

10 = Opening pressure 10 bar

12 = Opening pressure 12 bar

blank = NBR (Nitrile) seal (standard)

V = FKM (Viton) seal

blank = O-ring sealing, valve face flat, cavity type REG-03

OR118= O-ring sealing, valve face with 118° phasing, cavity type REG-04

Related data sheets

Reference	Description
170-P-051600	Mounting tool for series RKVE... and RV...
170-P-059000	Using nozzles or orifices before a Check Valve