

# Flow valve Flow divider

$Q_{\max} = 100 \text{ l/min}$ ,  $p_{\max} = 315 \text{ bar}$

Bidirectional,

Type series: MTDA083F

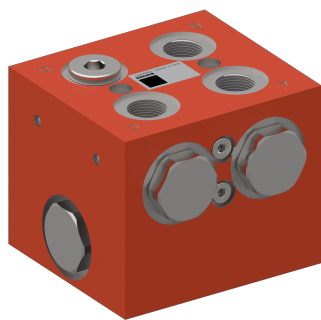

- Pipe line mounting valve
- ZnNi plating ( $\geq 480\text{h}$  DIN EN ISO 9227 NSS)
- Robust, uncomplicated, reliable
- Service-friendly
- Flows can be split or merged with accuracy (divide/combine functions)
- The flow division ratio can be modified to customer requirements
- ZnNi plating ( $\geq 480\text{h}$  DIN EN ISO 9227 NSS)

## Symbol

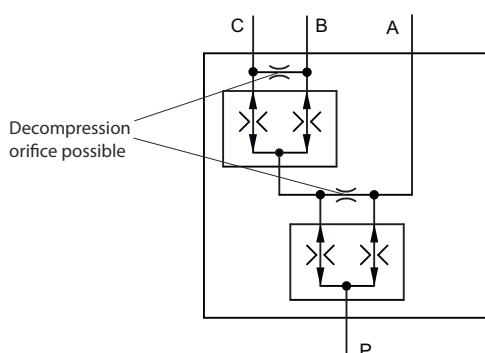

## Description

The MTDA083F unit is a three-way flow control valve. The valve divides a flow, the total rate of which may be varied, up to 3 part-flows. When the flows pass through a valve in the opposite direction, the part-flows are combined into one single flow (added). The dividing and combining functions are largely independent of the pressure of the divided flows and of the fluid viscosity.

In order for the valve to work properly, a continuous flow is required at all ports. For example, if one actuator is no longer able to move, then the other part-flow will also be restricted. If the actuators served by the flow divider operate at different pressures, then the pressure of the total flow entering the valve will correspond to the higher of the two actuator pressures. Large pres-

sure differences may give rise to significant heat generation, which must be taken into consideration when designing the system.

## Technical data

General characteristics	Description, value, unit
Function group	flow valve
Function	flow divider
Design	pipe line mounting valve
Characteristic	bidirectional
MTTFd value	150 years
Thread size	several, see chapter "Dimensions, Sectional View"
Mounting attitude	see chapter "Installation information"
Weight	8.3 kg
Minimum ambient temperature	- 20 °C
Maximum ambient temperature	+ 80 °C
Surface protection	ZnNi plating (≥480h DIN EN ISO 9227 NSS)
Sealing material	NBR (nitril-butadien-rubber / BUNA) seals

Hydraulic characteristics	Description, value, unit
Maximum operating pressure	315 bar
Maximum flow rate	100 l/min
Control flow range	008 - 100 l/min
Flow direction	see symbol
Hydraulic fluid	HL and HLP mineral oil according to DIN 51 524; other fluids on request!
Minimum fluid temperature	- 20 °C
Maximum fluid temperature	+ 80 °C
Viscosity range	10 ... 300 mm <sup>2</sup> /s (cSt)
Minimum fluid cleanliness (cleanliness class according to ISO 4406:1999)	class 20/18/15

## Performance graphs

measured with oil viscosity 35.0 mm<sup>2</sup>/s (cSt)

% = f (Q<sub>zu</sub>) Division accuracy

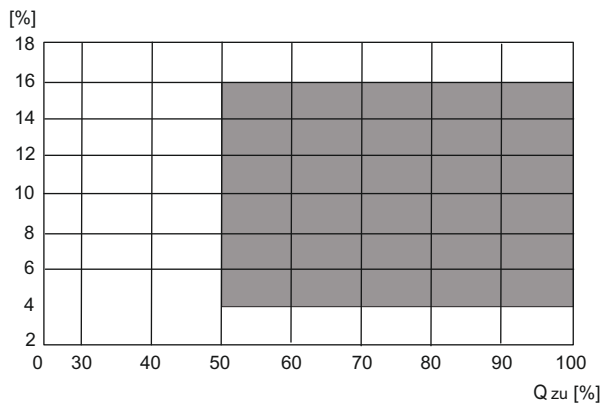

Division accuracy ± 3% of the max. flow rate, based on control flow range of the respective flow divider.

Δp = f (Q) Pressure drop-flow rate characteristic

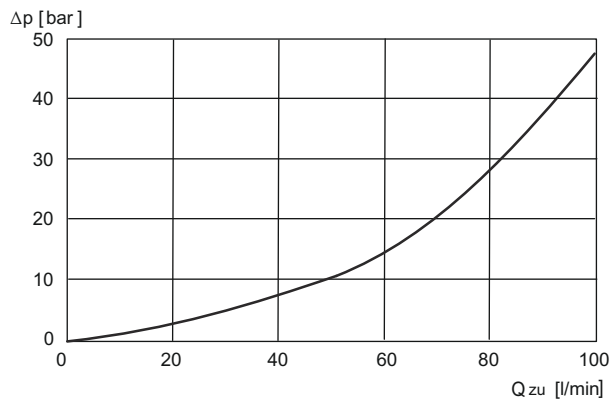

Q<sub>zu</sub> = inlet flow (0% = 0 l/min, 100% = maximum control flow)  
Higher division accuracy on request.

## Installation

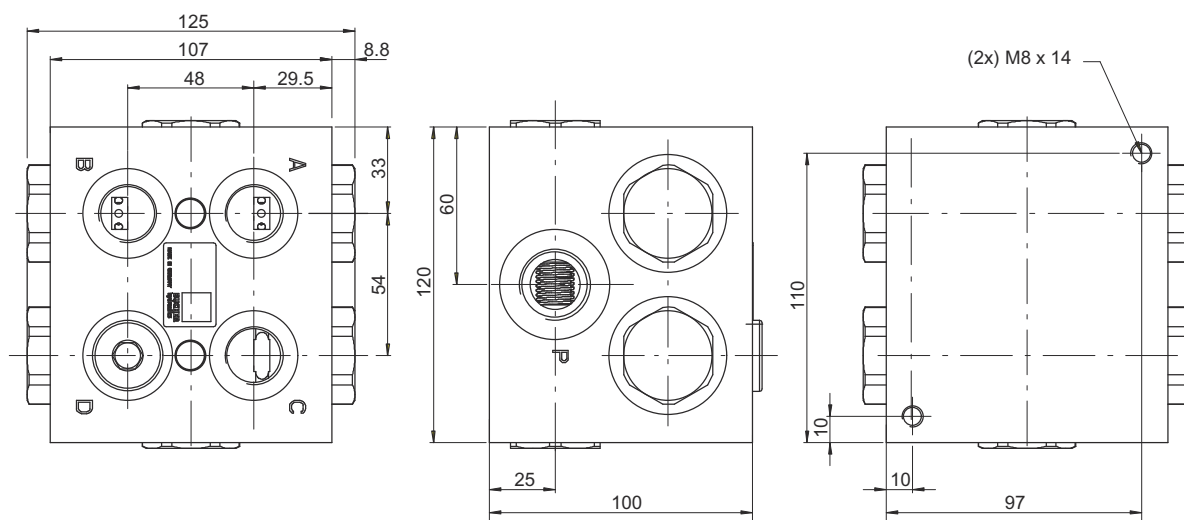

Port threads

Flow range [l/min]	Metric		
	Port P	Port A+B	Port C+D
009 ... 100	M27 x 2	M22 x 1,5	M22 x 1,5

**ATTENTION!**

Expert and product knowledge is required for the layout of this valve type. Use exclusively for the intended purpose within the indicated values. The valve manufacturer must be consulted for use of the appliance outside the specifications. All applications must be verified by sufficient tests to ensure safety in the application. The ultimate responsibility for safety during installation and use resides with the end appliance manufacturer.

**ATTENTION!**

Only qualified personnel with mechanical skills may carry out any maintenance work. Generally, the only work that should ever be undertaken is to check, and possibly replace, the seals. When changing seals, oil or grease the new seals thoroughly before fitting them.

**NOTE!**

When one of the two cylinders reaches its end-stop, the second cylinder also stops at first. This pressure-dependent leakage flow enables the other cylinder to slowly re-synchronise itself. To enable fullspeed re-synchronisation of the lagging cylinder, each actuator line from the flow divider must be equipped with a pressure relief valve.

**NOTE!**

To prevent the weight of the spool causing division inaccuracies, the valve must be installed so that the spool axis is horizontal. When mounting the valve, make sure that the body is not subjected to any distorting forces. Do not use tapered-thread pipe fittings.

## Application examples

Application examples:

- Work access platforms
- Lifting platforms
- Harvester
- Municipal equipment
- Snow/ice clearing equipment
- Wood chippers
- Road rollers
- Tail lifts

Ordering code

MT D A 08 3F 10 10 025 - M 1

- MT = Flow divider
- D = Bi-directional
- A = Port thread
- 08 = Nominal size
- 3F = Tripple flow divider
- 10 = Division ratio A to B+C  
10 = 1:1  
15 = 1,5 etc. 1)
- 10 = Division ratio A to B+C  
10 = 1:1  
15 = 1,5 etc. 1)
- 004 = Control flow range 2 – 4 l/min
- 006 = Control flow range 3 – 6 l/min
- 008 = Control flow range 4 – 8 l/min
- 012 = Control flow range 6 – 12 l/min
- 016 = Control flow range 8 – 16 l/min
- 025 = Control flow range 12 – 25 l/min
- 032 = Control flow range 16 – 32 l/min
- 050 = Control flow range 25 – 50 l/min
- 075 = Control flow range 37 – 75 l/min
- 100 = Control flow range 50 – 100 l/min (higher flow rates on request)
- M = Port thread Metric
- 1 = Revision level (will be inserted by the company)

1) With unequal division: For the division ratio A to B+C, the larger part-flow must be at port B+C.  
For the division ratio B to C, the larger part-flow must be at port C.

**Example Division MTDA083F201050**

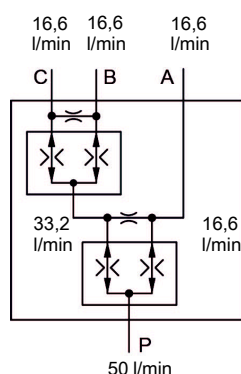

A = 16,6 l/min  
B = 16,6 l/min  
C = 16,6 l/min