

## Proportional Directional Valves

Series L.8S

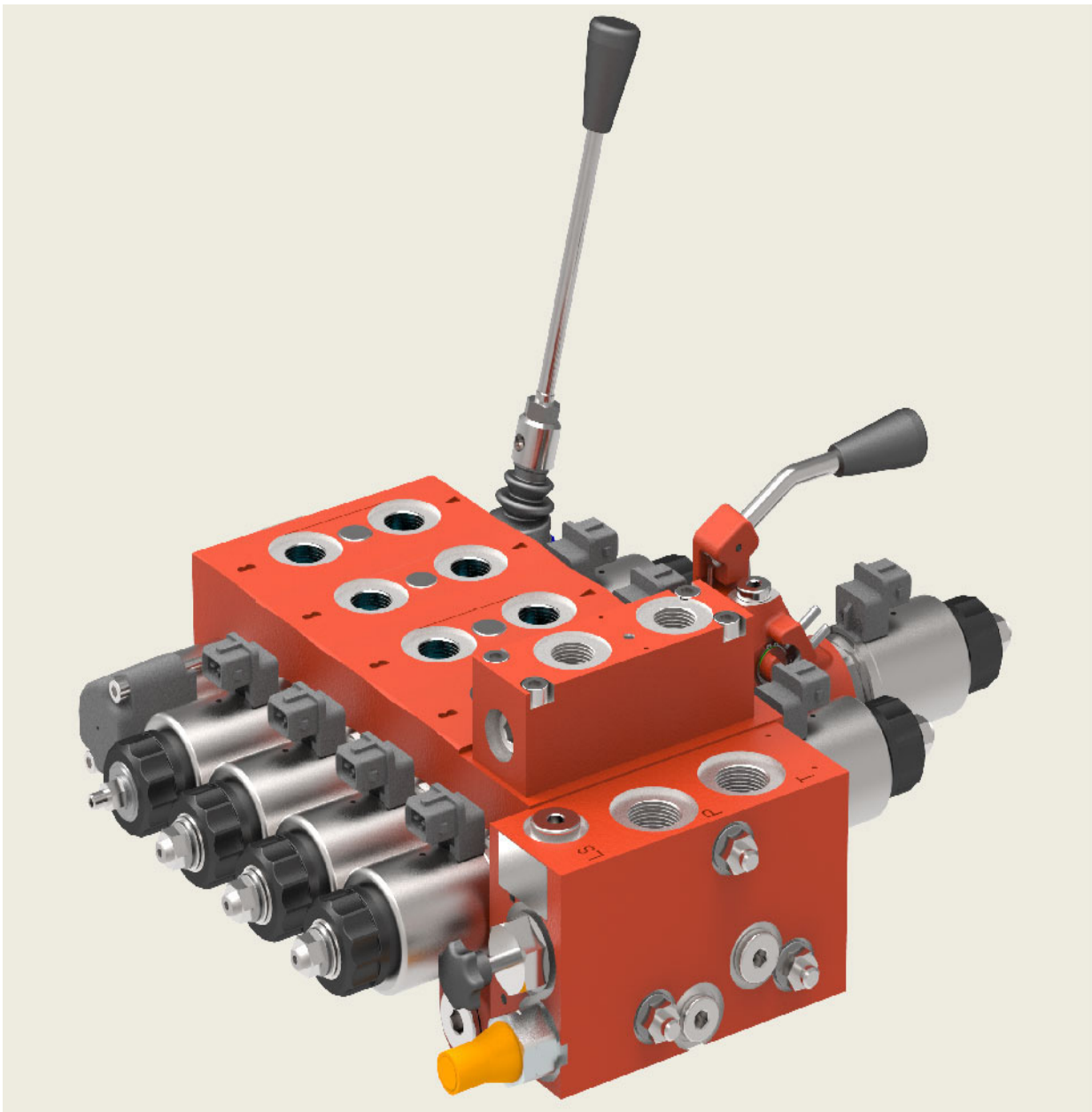



Contents	Page
<b>1</b>	<b>General description</b> ..... 5
1.1	Note on the unique identification of the various sections ..... 6
<b>2</b>	<b>The main components</b> ..... 7
2.1	Inlet- and end sections for valve blocks ..... 7
2.2	Inlet and intermediate sections ..... 7
2.3	Directional valves ..... 7
2.4	Auxiliary valves ..... 8
2.5	General technical data ..... 8
<b>3</b>	<b>Inlet sections</b> ..... 9
3.1	Inlet sections without function ..... 9
3.2	Inlet sections with pressure relief ..... 10
3.3	Inlet sections with 2-way compensator ..... 12
3.4	Inlet sections with 3-way compensator ..... 13
<b>4</b>	<b>Intermediate sections</b> ..... 18
4.1	Intermediate sections with no control function ..... 18
4.2	Intermediate sections with 2-way pressure compensator ..... 19
4.3	Intermediate sections with 3-way pressure compensator ..... 20
4.4	Intermediate sections with priority function ..... 22
4.5	Intermediate sections with multi-way pressure compensator ..... 23
4.6	Intermediate section with proportional pressure reducing valve ..... 25
<b>5</b>	<b>Directional valves</b> ..... 27
5.1	LA8S-/ LF8S- Directional valves ..... 27
5.2	LD8S-/ LC8S- Directional valves ..... 34
5.3	LM8S-/ LP8S- Directional valves ..... 42
5.4	LH8S-Directional valves ..... 48
<b>6</b>	<b>Auxiliary valves that bolt-on to the top flange face O</b> ..... 53
6.1	Anti-shock / make-up valves (secondary pressure relief) ..... 53
6.2	Check valves (pilot operated non return valves) ..... 55
6.3	Load check valves with anti-shock / make-up valves (pilot operated non-return valve with pressure relief on the actuator side) ..... 58
6.4	Load control valves ..... 60
<b>7</b>	<b>Auxiliary valves that bolt-on to the bottom flange face U</b> ..... 62
7.1	Individual pressure compensator without / with flow cut-off (torque-limiting) ..... 62
7.2	Flow limiter without / with individual pressure compensators ..... 64
7.3	Pressure reducing compensators ..... 66

---

8	End sections .....	69
	8.1 End sections with no control function .....	69
	8.2 Priority section .....	70
	8.3 With direct-acting pressure relief .....	72
	8.4 With pressure reducing function e.g. for hydraulic joystick .....	73
	8.5 Load control valve with float position .....	74
	8.6 Safety valve for electro-hydraulic steering systems .....	76
<hr/>		
9	Accessories .....	78
	9.1 Seat valves series SVH04 .....	78
	9.2 Analogue systems .....	79
	9.3 Proportional amplifier .....	79
	9.4 Assembly kit .....	79
<hr/>		
10	Liability .....	79
<hr/>		
11	Note .....	79

# 1 General description

The L.8S valve series was developed for mobile applications and it features a robust design and small external dimensions.

The L.8S valve range is a very flexible building-block system - its elements can be selected and assembled into a valve block that provides the necessary functions and precisely meets the needs of the application.

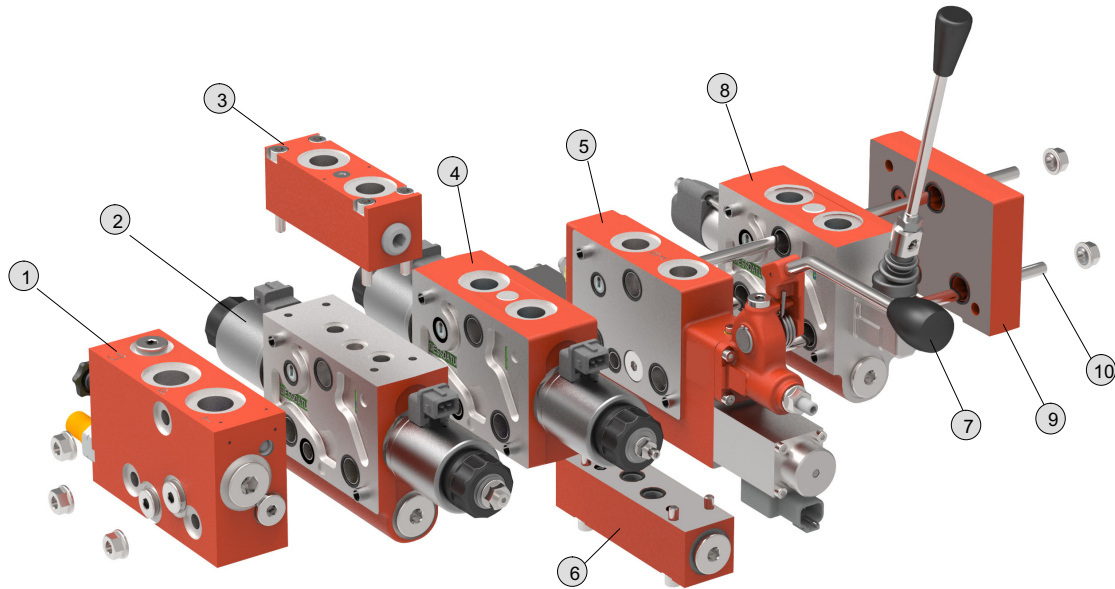

	Description
1	Inlet section with 3-way compensator (chapter 3)
2	Directional sections with flange face for auxiliary valve, and integral individual pressure compensator / solenoid, direct-acting (chapter 5)
3	Auxiliary valves that bolt-on to the top flange face O (chapter 6)
4	Directional valve with direct-acting proportional solenoid (chapter 5)
5	Directional sections with port threads and flange face for auxiliary valve / solenoid, two-stage (chapter 5)
6	Auxiliary valves that bolt-on to the bottom flange face U (chapter 7)
7	Directional valve manually operated (chapter 5)
8	Directional valve manually operated (chapter 5)
9	End section (with no control function) (chapter 8)
10	Tie-rod (chapter 9.4)

The following components are available within the range:

**Block termination components**

- inlet sections
- end sections

**Intermediate sections**

- 2-way pressure compensators
- 3-way pressure compensators
- multi-way pressure compensators

**Directional valves with auxiliary valves**

- load check valves
  - anti-shock valves
  - individual pressure compensators (2-way)
- and many more.

Within the valve block, directional valve sections are connected in parallel to the pressure, tank and control lines.

In a system with a fixed-displacement pump, a typical valve block contains a 3-way compensator, several directional valves and the necessary block termination components. The pump is connected to the valve block by a pressure line.

When all directional valves are in the neutral position, the control line unloads the 3-way compensator to tank. The entire flow supplied to the valve therefore passes - with minimal unloaded pressure drop - through the 3-way compensator to the tank port or the carry-over port.

When one of the directional valves is operated, the load pressure is signaled through the control line to the 3-way compensator. The 3-way compensator keeps the pressure difference between the pressure and control galleries inside the block at a constant level (the control pressure). The flow rate to the actuator is therefore always independent of the load and proportional to the open flow area of the metering orifice in the directional valve that has been operated.

In a system with a pressure-controlled, variable-displacement pump, a typical valve block contains (in addition to the directional valves and block termination components) a

2-way compensator that must be positioned between the pump port and the pressure gallery inside the block.

When all directional valves are in the neutral position, the 2-way compensator closes the inlet to the valve block. When one of the directional valves is operated, the 2-way compensator reduces the inlet pressure to a level sufficient to keep the pressure difference between the pressure and control galleries inside the block at a constant level. This ensures that the flow rate to the actuator is independent of the load and proportional to the open flow area of the metering orifice in the directional valve. The flow rate supplied to the valve block therefore matches the actual demand.

When a valve block is supplied by a variable-displacement pump with a load-sensing control, the pump can be connected directly to the valve block by a pressure line. In addition, the control line is connected to the pump control port. If the control pressure can be adjusted directly at the pump control, it is then possible to set the actuator flow rate to the specified value without any additional measures.

If the pump control pressure is preset, the specified flow rate is achieved by placing a 2-way compensator before the directional valve.

When all directional valves are in the neutral position, the pump is de-stroked. When one of the directional valves is operated then, due to the effect of either the pump control or the 2-way compensator positioned before the directional valve, the necessary control pressure is maintained between the pressure and control galleries inside the block. The flow to the selected actuator is therefore independent of the load and proportional to the open flow area of the metering orifice in the directional valve.

In all of the system configurations described up to this point, when several directional valves are operated then, thanks to the shuttle valves situated in the control lines, the actuator with the highest load will dictate the control pressure and the flow rate to the actuator will be independent of the load and proportional to the open flow area of the metering orifice in the directional valve. Load-independence for the less highly-loaded actuators can be achieved by using individual pressure compensators, which reduce the excessive pressure difference sufficiently to ensure that the required control pressure exists at the corresponding directional valve.

## 1.1 Note on the unique identification of the various sections

For all adjustable sections (auxiliary-function sections and directional sections), the flow rate specification Q= and pressure specification P= must be stated clearly and within

the limits of the prescribed flow rate and pressure specifications. These can be found in the relevant document section.

### 1.1.1 Example

Example 1:

LU8SSCS-0M22\*\*00/P=

=> LU8SSCS-0M22\*00/P=210

Example 2 with spool stroke limiter:

LD8SE4A2525-S\*L-1M18T18\*00/P=

=> LD8SE4A2525-S\*L-1M18T18\*00/P=180QA=18QB=21

The products are assembled in accordance with the specified setting parameters.

## 2 The main components

### 2.1 Inlet- and end sections for valve blocks

Every L.8S series valve block requires two block termination components in the form of one inlet section and one end section. These two components are used for mounting the block, the block tie bolts pass through them, and they are provided with hydraulic ports.

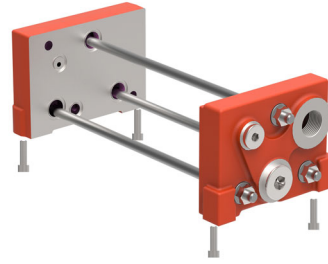

### 2.2 Inlet and intermediate sections

#### 2.2.1 2-way pressure compensator

The 2-way compensator is a valve that controls a pressure differential. It is situated inside the block, before the pressure gallery. In this valve, the inlet pressure is reduced by the amount needed to ensure that the control pressure between the pressure and control galleries inside the block is kept constant. In some models, the valve closes the inlet to the block if the pressure in the control line reaches the setting of an upstream pressure relief valve.

The 2-way compensator can be supplied as an inlet section or an intermediate section.

#### 2.2.2 3-way pressure compensator

The 3-way compensator is a valve that controls a pressure differential. It is situated between the pressure gallery and the tank or carry-over gallery. The valve keeps the pressure difference between the pressure and control galleries inside the block at a constant level and surplus flow passes to the tank or carry-over port. If the pressure in the control line reaches the setting of an upstream pressure relief valve, the 3-way compensator opens the connection to tank, thus limiting the pressure in the pressure gallery inside the block. In one particular model, the function of the 3-way compensator can be customized to suit the requirements of individual applications. The adjustment can be done with a shut-off screw that is accessible from the outside.

### 2.3 Directional valves

The control options (LA, LF, LH, LC and LP or ON/OFF (LM, LD) for L.8S series directional valves enable continuous changes to the flow area of the metering orifice, which in turn determines the flow rate that is supplied to the actuator. This is achieved by arranging that in the first group of valves the spool can stop at any desired point along its total stroke, whereas the spools of LM/LD valves travel from one end of the stroke to the other when they are switched, and do not stop at intermediate positions.

The various directional valves are differentiated by their type of operation. The LA directional valves are mechanically operated by hand lever. The LF directional valves are mechanically operated by remote cable. The LD and LC directional valves are electrically operated, direct acting. The LM and LP directional valves have electro-hydraulic operation. The solenoids of LD, LC, LM and LP directional valves are fitted with a manual override as standard, but in the case of the LM and LP valves the overrides only work if pressure is present at the valve inlet. Series LD, LC, LH, LM and LP directional valves can be equipped with an optional hand lever for manual-override operation of the valve spool. Operating two valves in parallel is dependent on the pressure demands of the actuator connected to each valve. However, the LD-, LC-, LA- and LF- directional valves can optionally be ordered with an integral individual pressure compensator.

### 2.4 Auxiliary valves

The auxiliary valves fit onto the directional valves and can be flange-mounted on the top (connection face O) or bottom (connection face U) of the valve, which is specially designed for this purpose.

For mounting on connection face O, these alternative auxiliary valves are available:

- anti-shock valve (secondary pressure relief valve with make-up facility)
- load control valve
- load check valve (hydraulically and electrically pilot-operated check valve)
- various special bolt-on plates

Anti-shock valves are used to prevent over-pressure in the actuator lines and/or cavitation with negative loads.

Load control valves provide controlled, load-independent lowering of over-running (pulling) loads. The anti-shock function is integrated and optimal adjustable.

Load check valves hold the actuator, which may be under load, with virtually zero leakage. The actuator is released by applying pressure to the other actuator port.

For mounting on connection face U, these alternative auxiliary valves are available:

- individual pressure compensator
- flow limiter
- pressure-reducing compensator

An individual compensator is used when the flow rate to the actuator must be independent of load, but the inlet compensator cannot perform the necessary pressure-control function. LA-, LC-, LD and LF-directional valves are also available with integrated individual pressure compensator.

Additional function blocks are described in detail in the relevant sections.

### 2.5 General technical data

General characteristics	Unit	Description, value
Recommended mounting attitude		With spool axis horizontal
Nominal flow rate	l/min	max. 150
Actuator flow rate	l/min	max. 60
Inlet pressure P + D	bar	max. 300 <sup>2)</sup>
Actuator pressure A + B	bar	max. 300 <sup>2)</sup>
Intermittent pressure (max. 10 sec/min)	bar	max. 315
Return line pressure	bar	max. 40 <sup>1)</sup>
Hydraulic fluid		Recommendation: high-quality fluids with a mineral-oil base, such as HLP oils to DIN 51524 part 2
Seal material		NBR
Fluid temperature	°C	-25 ... +80
Ambient temperature	°C	-25 ... +50
Viscosity range	mm <sup>2</sup> /s	10 ... 375
Minimum fluid cleanliness level		ISO 446 code 20/18/15
Nominal voltage range of switching solenoids	V DC	12V $\triangleq$ 10,8 ... 14 24V $\triangleq$ 21,6 ... 28
Servo frequency	Hz	preferably 100
Threaded ports		to DIN 3852 and DIN ISO 228-1
Tie-rod		M8, tensile grade 10.9 (tightening torque 30Nm)
Corrosion protection		Valve blocks primed colour: black RAL 9005 coating thickness 30 to 50 $\mu$ m <sup>3)</sup>
MTTF <sub>D</sub> values		150 years, see datasheet 100-KB-000083

1) 100 bar return line pressure for brief periods, with max. inlet pressure 210 bar. 210 bar for P and T in individual cases. For higher pressures, contact Bucher Hydraulics.

2) The stated pressures are the maximum absolute pressure limits for a tank line pressure of 10 bar.  
Note: Some components have lower individual pressure ratings.

### 3 Inlet sections

#### 3.1 Inlet sections without function

##### 3.1.1 Description

Inlet sections without function are used to begin the block when no control functions are needed (e.g. LS applications). Ports P, T and LS, and tapped holes for securing the valve block are provided.

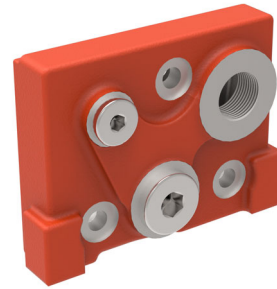

##### 3.1.2 Overview of sections

Symbol	Description	Part number
	<b>LU8SPOG-0M22*00</b> <ul style="list-style-type: none"> <li>without function</li> <li>port threads to DIN 3852 - M22 x 1,5</li> </ul>	<b>100020638</b>
	<b>LU8SPOG-0M26*00</b> <ul style="list-style-type: none"> <li>without function</li> <li>port threads to DIN 3852 - M26 x 1,5</li> </ul>	<b>100020639</b>

##### 3.1.3 Dimensions

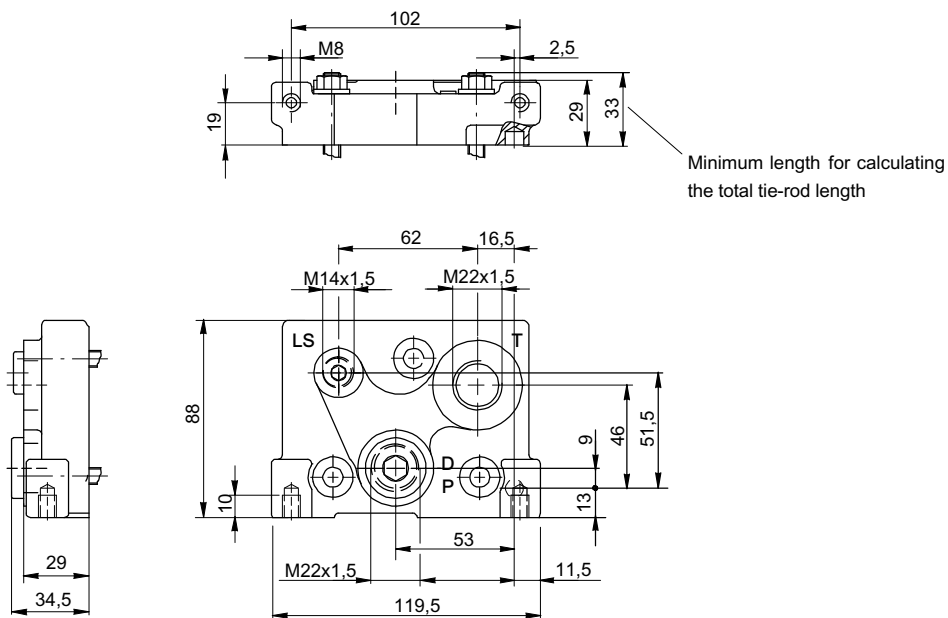

## 3.2 Inlet sections with pressure relief

### 3.2.1 Description

**3.2.1.1 Inlet pressure relief two-stage LU8SPOD**  
This is used to begin the block, and has an integral two-stage pressure relief function (e.g. safety pressure relief in an LS system). Ports P, T and LS, and tapped holes for securing the valve block are provided.

**3.2.1.2 Inlet pressure relief direct acting LU8SPOS**  
This is used to begin the block, and has an integral direct-acting pressure relief function (e.g. secondary pressure relief in an LS system). The application limits must not be exceeded. By screwing in damping and bypass orifices, many possibilities for combating oscillation problems in LS systems can be created. Ports P, T and LS, and tapped holes for securing the valve block are provided.

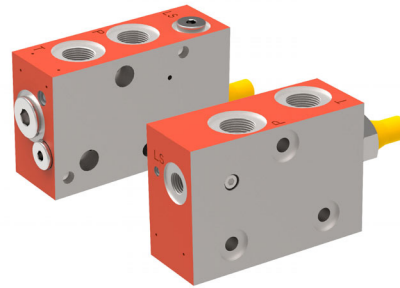

### 3.2.2 Technical data

General characteristics	Unit	Description, value
Inlet pressure	bar	max. 300
Nominal flow rate	l/min	see performance graphs 3.2.3
Pressure relief	bar	adjustable

### 3.2.3 Performance graphs

#### 3.2.3.1 Inlet pressure relief two-stage LU8SPOD

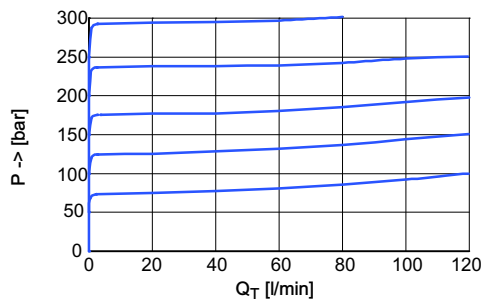

#### 3.2.3.2 Inlet pressure relief direct acting LU8SPOS

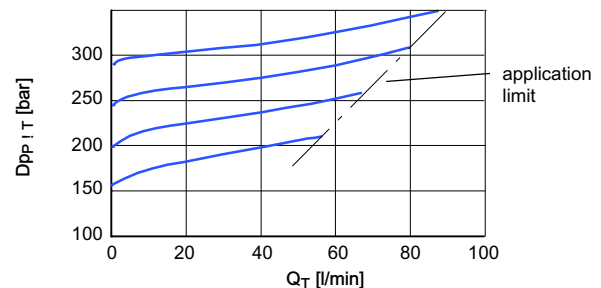

### 3.2.4 Overview of sections

#### 3.2.4.1 Inlet pressure relief two-stage

Symbol	Description	Part number
	<b>LU8SPOD-0M22*00/P=</b> <ul style="list-style-type: none"> <li>relief adjustment range 60 ... 300 bar</li> <li>nominal flow rate 120 l/min</li> <li>pressure relief adjustable P =</li> <li>port threads to DIN 3852 - M22 x 1,5 ⇒ Sspecify the pressure relief setting in bar</li> </ul>	see order details chapter 1.1

	<b>LU8SPOD-0M26*00/P=</b>	see order details chapter 1.1
	<ul style="list-style-type: none"> <li>• relief adjustment range 60 ... 300 bar</li> <li>• nominal flow rate 120 l/min</li> <li>• pressure relief adjustable P =</li> <li>• port threads to DIN 3852 - M26 x 1,5</li> <li>• port thread pressure M22 x 1,5</li> <li>• port thread tank M26 x 1,5</li> </ul> <p>⇒ Specify the pressure relief setting in bar</p>	

### 3.2.4.2 Inlet pressure relief direct acting

Symbol	Description	Part number
	<b>LU8SPOS1-0M22*00/P=</b>	see order details chapter 1.1
	<ul style="list-style-type: none"> <li>• application limit see performance graph</li> <li>• relief adjustment range 35 ... 95 bar P =</li> <li>• port threads to DIN 3852 - M22 x 1,5</li> </ul> <p>⇒ Specify the pressure relief setting in bar</p>	
	<b>LU8SPOS2-0M22*00/P=</b>	see order details chapter 1.1
	<ul style="list-style-type: none"> <li>• application limit see performance graph</li> <li>• relief adjustment range 95 ... 210 bar P =</li> <li>• port threads to DIN 3852 - M22 x 1,5</li> </ul> <p>⇒ Specify the pressure relief setting in bar.</p>	
	<b>LU8SPOS3-0M22*00/P=</b>	see order details chapter 1.1
	<ul style="list-style-type: none"> <li>• application limit see performance graph</li> <li>• relief adjustment range 210 ... 300 bar P =</li> <li>• port threads to DIN 3852 - M22 x 1,5</li> </ul> <p>⇒ Specify the pressure relief setting in bar.</p>	

## 3.2.5 Dimensions

### 3.2.5.1 LU8SPOD-...

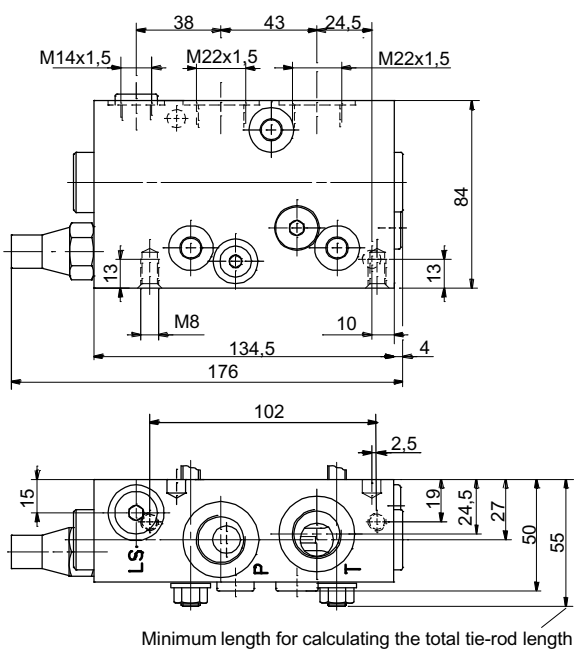

### 3.2.5.2 LU8SPOS-...

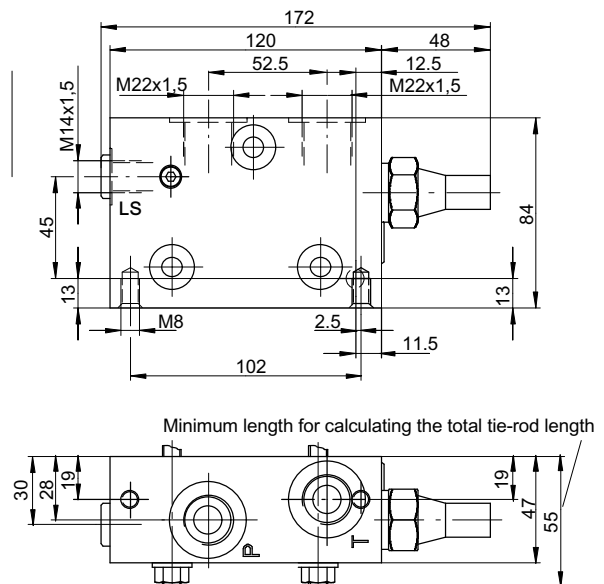

## 3.3 Inlet sections with 2-way compensator

### 3.3.1 Description

These are used to begin the block and have an integral 2-way compensator; optionally with flow cut-off from a pre-set pressure. A typical application is the parallel operation of two valve blocks in an LS-system, where only one spool at a time is operated within each block. Ports P and LS, and tapped holes for securing the valve block are provided. The tank connection must be implemented in the intermediate or end section.

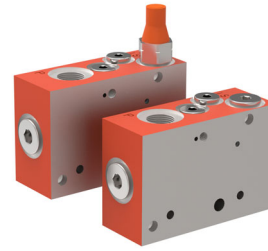

### 3.3.2 Technical data

General characteristics	Unit	Description, value
Inlet pressure	bar	max. 300
Nominal flow rate	l/min	100
Pressure relief	bar	adjustable, 50 ... 300
Port threads to DIN 3852	bar	M22x1,5

### 3.3.3 Performance graphs

#### 3.3.3.1 Variation of the actuator flow rate with inlet pressure when using an LU8SSKA / SKB inlet section

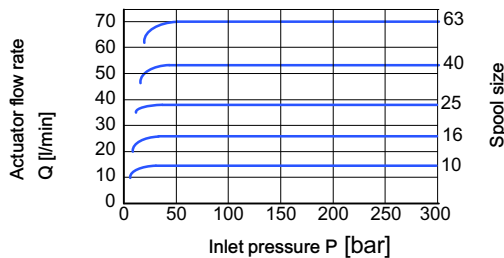

#### 3.3.3.2 Flow cut-off function with an LU8SSKB inlet section

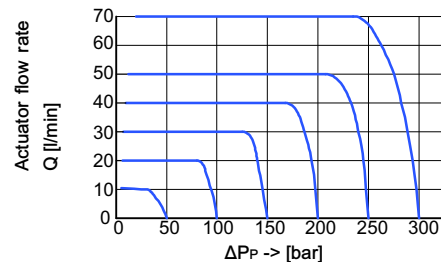

### 3.3.4 Overview of sections

Symbol	Description	Part number
	<b>LU8SSKA-0M22*00</b> • control $\Delta p = 12$ bar / without flow cut-off	<b>100022874</b>
	<b>LU8SSKB-0M22*00/P=</b> • control $\Delta p = 12$ bar / with flow cut-off ⇒ Specify the pressure relief setting in bar	see order details chapter 1.1

### 3.3.5 Dimensions

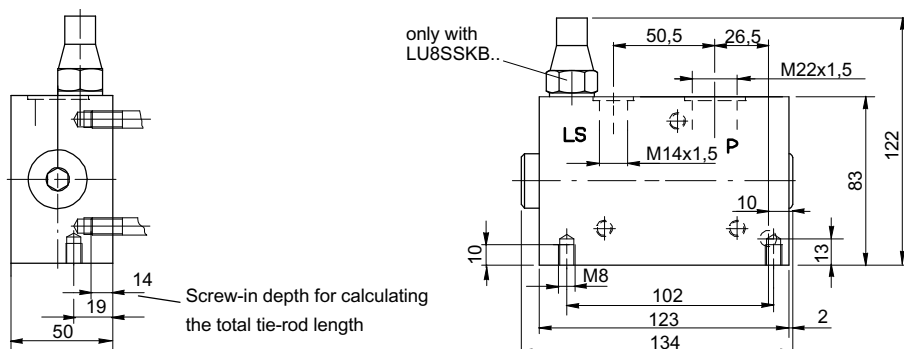

### 3.4 Inlet sections with 3-way compensator

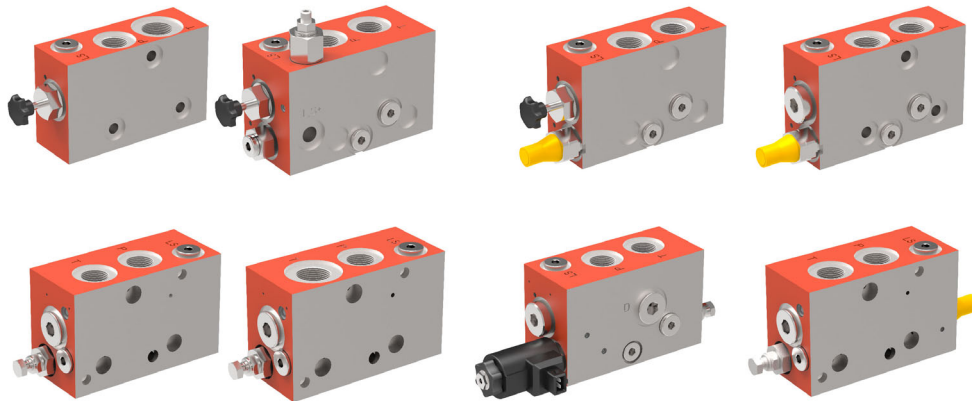

#### 3.4.1 Description

These are used to begin the block and have an integral 3-way compensator; optionally with the additional functions shown below. These inlets are used with fixed displacement pumps.

In essence, they can be applied in conjunction with a fixed-displacement pump for control of unloading and flow control that is independent of the load.

- **LU8SSCK**  
Provides a 3-way compensator function with the facility to change over to LS- or constant pressure systems. This is typical with towed harvesters.
- **LU8SSCK\*29**  
Provides a 3-way compensator function, with the ability to change over to LS or constant-pressure systems. In the case of reduced flow rates caused by increased pressure losses in the P line, or if the load sensing line has a large leakage or is connected to tank through an orifice (bleed-off), the integral adjustable pressure booster can amplify the LS signal accordingly. In special cases, increased amplification of the LS signal can result in higher actuator flow rates and thus increase the performance of the system.
- **LU8SSCL**  
Provides a 3-way compensator function and two-stage pressure relief that is adjustable from outside the valve, with the ability to change over to LS or constant-pressure systems. This is typical with towed harvesters. The pressure relief is only operative in the open system.
- **LU8SSCS**  
Provides a 3-way compensator function and 2-stage pressure relief that is adjustable from outside the valve.
- **LU8SSCU**  
Provides a 3-way compensator function with an independent system pressure relief function.

- **LU8SSCX**  
Provides a 3-way compensator function and two-stage pressure relief that is adjustable from outside the valve, and an independent system pressure relief function. The surplus flow is available at port D for other applications. The valve block's own functions have priority over port D. The valve block can be protected at a lower pressure setting by the two-stage relief valve, so that excess flow is always available at port D.
- **LU8SSCW**  
Provides a 3-way compensator function with an independent system pressure relief function. The surplus flow is available at port D for other applications. The valve block's own functions have priority over port D. When the valve block's pressure relief function is active, there is no longer any flow to port D.
- **LU8SSCE**  
Provides a 3-way compensator function with an independent system pressure relief function. When it is de-energised, a 2/2 seat valve unloads the internal LS line to tank, which means that the seat valve must first be energised before the valve block is functional. Applications are in safety circuits, e.g. emergency stop controls.

### 3.4.2 General technical data

General characteristics	Unit	Description, value
Inlet pressure	bar	max. 300
Nominal flow rate	l/min	120
Unloaded pressure P -> T (D)	bar	see performance graphs chapter 3.4.3
Pressure relief	bar	adjustable, 50 ... 300 <sup>2)</sup>
Nominal voltage <sup>1)</sup>	V DC	12 or 24
Plug type		AMP Junior Timer, Deutsch DT04-2P-EP04
Power consumption <sup>1)</sup>	Watt	27
Duty cycle <sup>1)</sup>	%	100
Protection class <sup>1)</sup>		AMP: IP65 DT: IP67 (DIN EN 60529)

1) Only with LU8SSCE.

2) Higher pressures on enquiry.

### 3.4.3 Performance graphs

#### 3.4.3.1 Maximum flow rate at directional valve (without individual pressure compensator) when using an LU8SSC inlet section.

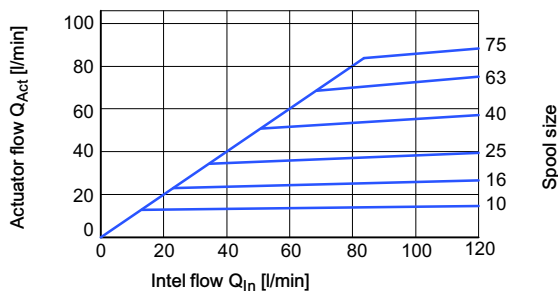

#### 3.4.3.2 Unloaded pressure in neutral position, (for other unloaded pressures consult Bucher Hydraulics).

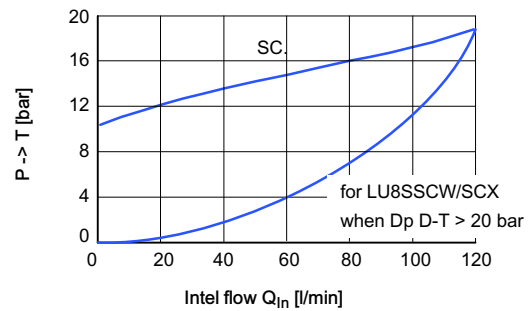

#### 3.4.3.3 Two-stage pressure relief characteristic inlet section LU8SSCS / SCX

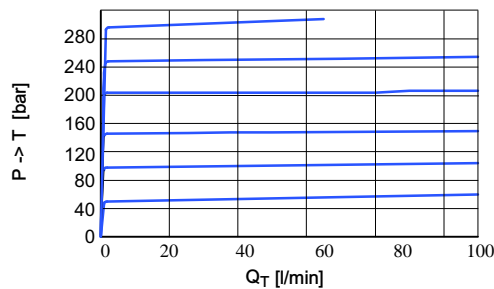

#### 3.4.3.4 System pressure relief characteristic inlet section LU8SSCE / SCU / SCW / SCX

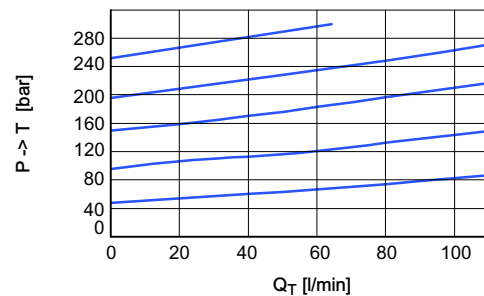

### 3.4.4 Overview of sections

Symbol	Description	Part number
	<b>LU8SSCK-0M22*00</b> <ul style="list-style-type: none"> <li>without pressure relief</li> <li>compensator can be disabled for LS systems</li> <li>control <math>\Delta p = 12</math> bar with active pressure compensator</li> <li>port threads to DIN 3852 - M22 x 1.5</li> </ul>	<b>100020640</b>

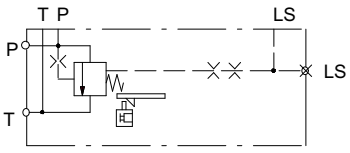
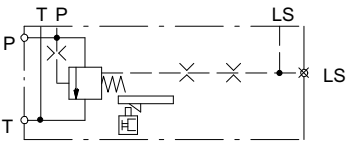
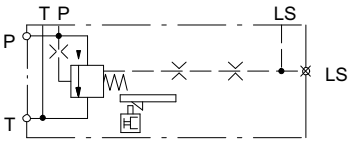
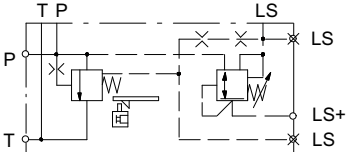
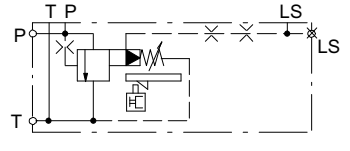
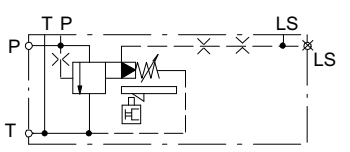
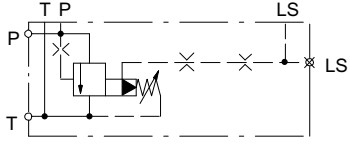
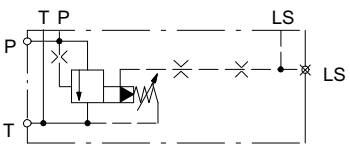
	<b>LU8SSCK-0M22*04</b>	<b>100020641</b>
<ul style="list-style-type: none"> <li>• without pressure relief</li> <li>• compensator can be disabled for LS systems</li> <li>• for using with seat valves SVH04M - straight-through tie bolts</li> <li>• control <math>\Delta p = 12</math> bar with active pressure compensator</li> <li>• port threads to DIN 3852 - M22 x 1.5</li> </ul>		
	<b>LU8SSCK-0M22*12</b>	<b>100030622</b>
<ul style="list-style-type: none"> <li>• without pressure relief</li> <li>• compensator can be disabled for LS systems</li> <li>• for using with seat valves SVH04M - straight-through tie bolts</li> <li>• control <math>\Delta p = 12</math> bar with active pressure compensator</li> <li>• no tank connection for bolt-on functions</li> <li>• port threads to DIN 3852 - M22 x 1.5</li> </ul>		
	<b>LU8SSCK-0M26*12</b>	<b>100023553</b>
<ul style="list-style-type: none"> <li>• without pressure relief</li> <li>• compensator can be disabled for LS systems</li> <li>• for using with seat valves SVH04M - straight-through tie bolts</li> <li>• control <math>\Delta p = 12</math> bar with active pressure compensator</li> <li>• no tank connection for bolt-on functions</li> <li>• port threads to DIN 3852 - M26 x 1.5</li> </ul>		
	<b>LU8SSCK-0M22*29</b>	<b>100036705</b>
<ul style="list-style-type: none"> <li>• without pressure relief</li> <li>• compensator can be disabled for LS systems</li> <li>• with integral LS-compensator, boost pressure 8 bar max., factory setting 6 bar.</li> <li>• control <math>\Delta p = 12</math> bar with active pressure compensator</li> <li>• port threads to DIN 3852 - M22 x 1.5</li> </ul>		
	<b>LU8SSCL-0M22*00/P=</b>	see order details chapter 1.1
<ul style="list-style-type: none"> <li>• with two-stage pressure relief in fixed-displacement pump system</li> <li>• control <math>\Delta p = 12</math> bar</li> <li>• port threads to DIN 3852 - M22 x 1.5</li> </ul> <p>⇒ Specify the pressure relief setting in bar</p>		
	<b>LU8SSCL-0M22*04/P=</b>	see order details chapter 1.1
<ul style="list-style-type: none"> <li>• with two-stage pressure relief in fixed-displacement pump system</li> <li>• for using with seat valves SVH04M - straight-through tie bolts</li> <li>• control <math>\Delta p = 12</math> bar</li> <li>• port threads to DIN 3852 - M22 x 1.5</li> </ul> <p>⇒ Specify the pressure relief setting in bar</p>		
	<b>LU8SSCS-0M22*00/P=</b>	see order details chapter 1.1
<ul style="list-style-type: none"> <li>• with two-stage pressure relief</li> <li>• control <math>\Delta p = 12</math> bar</li> <li>• port threads to DIN 3852 - M22 x 1.5</li> </ul> <p>⇒ Specify the pressure relief setting in bar</p>		
	<b>LU8SSCS-0M26*00/P=</b>	see order details chapter 1.1
<ul style="list-style-type: none"> <li>• with two-stage pressure relief</li> <li>• control <math>\Delta p = 12</math> bar</li> <li>• port threads to DIN 3852 - M26 x 1.5</li> </ul> <p>⇒ Specify the pressure relief setting in bar</p>		

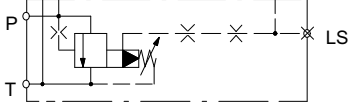
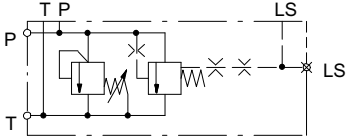
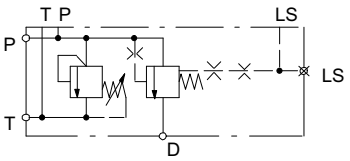
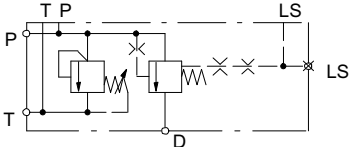
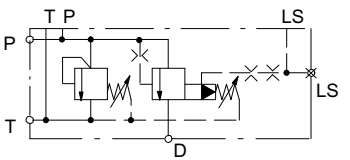
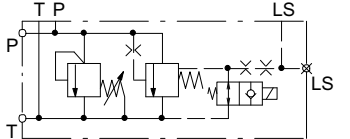
	<b>LU8SSCS-0M22*04/P=</b> • with two-stage pressure relief • for using with seat valves SVH04M - straight-through tie bolts • control $\Delta p = 12$ bar • port threads to DIN 3852 - M22 x 1.5 ⇒ Specify the pressure relief setting in bar	see order details chapter 1.1
	<b>LU8SSCU-0M22*00/P=</b> • with system pressure relief, direct acting, • control $\Delta p = 12$ bar • port threads to DIN 3852 - M22 x 1.5 ⇒ Specify the pressure relief setting in bar, (50 ... 315 bar)	see order details chapter 1.1
	<b>LU8SSCW-0M22*00/P=</b> • with system pressure relief • with surplus-flow port • internal valve block has priority over D • control $\Delta p = 12$ bar • port threads to DIN 3852 - M22 x 1.5 ⇒ Specify the pressure relief setting in bar, (50 ... 315 bar)	see order details chapter 1.1
	<b>LU8SSCW-0M26*00/P=</b> • with system pressure relief • internal valve block has priority over D • with surplus-flow port • control $\Delta p = 12$ bar • port threads to DIN 3852 - M26 x 1.5 ⇒ Specify the pressure relief setting in bar, (50 ... 315 bar)	see order details chapter 1.1
	<b>LU8SSCX-0M22*00/P=P1=</b> • with system pressure relief • with surplus-flow port • internal valve block has priority over D • with pressure relief for the valve block • control $\Delta p = 12$ bar • port threads to DIN 3852 - M22 x 1.5 ⇒ Specify the pressure relief setting in bar, (50 ... 315 bar)	see order details chapter 1.1
	<b>LU8SSCE-0M22J24*00/P=</b> • with direct-acting pressure relief function • emergency stop function • control $\Delta p = 12$ bar • port threads to DIN 3852 - M22 x 1.5 • plug type: AMP Junior Timer • nominal voltage 24 V DC ⇒ Specify the pressure relief setting in bar	see order details chapter 1.1

### 3.4.5 Connector socket

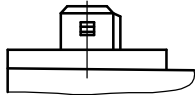
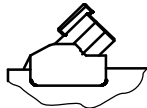
AMP Junior Timer <b>J</b>	Deutsch plug DT04-2P-EP04 <b>T</b>
	

### 3.4.6 Dimensions

#### 3.4.6.1 LU8SSCE-...G

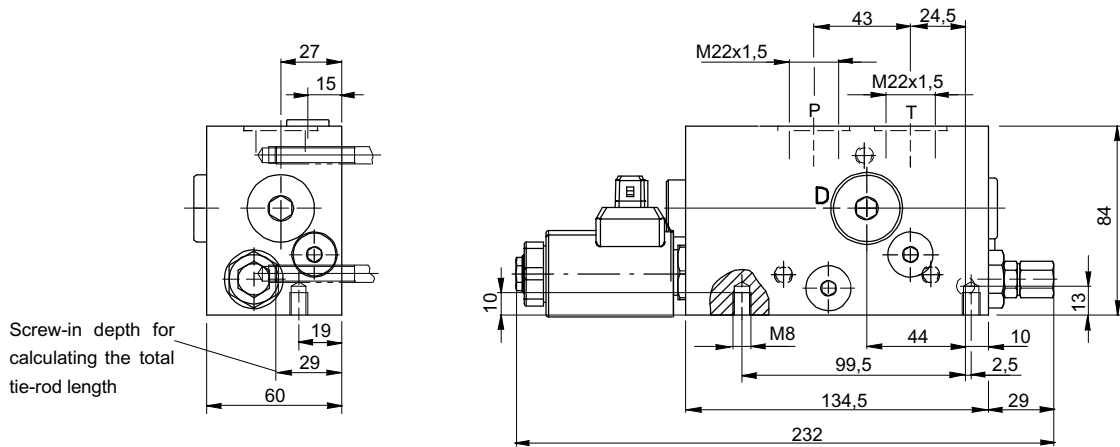

Screw-in depth for calculating the total tie-rod length

#### 3.4.6.2 LU8SSCK / SCS / SCL

Minimum length for calculating the total tie rod length for special feature, eg. /04

(Special feature / 04 is straight-through tie-rod)

Screw-in depth for calculating the total tie-rod length

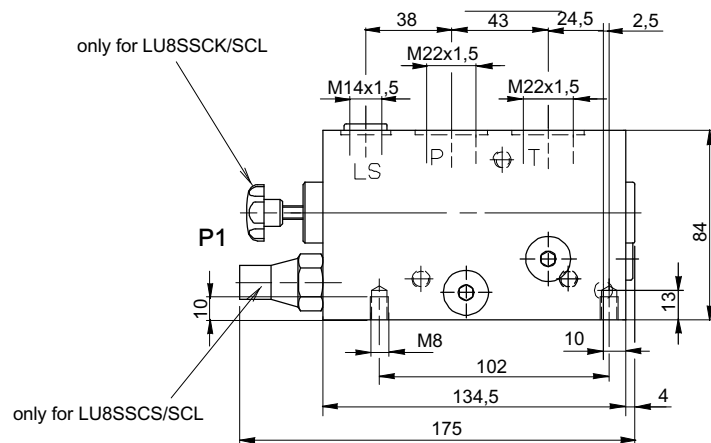

only for LU8SSCK/SCL

only for LU8SSCS/SCL

#### 3.4.6.3 LU8SSCU / SCW / SCX

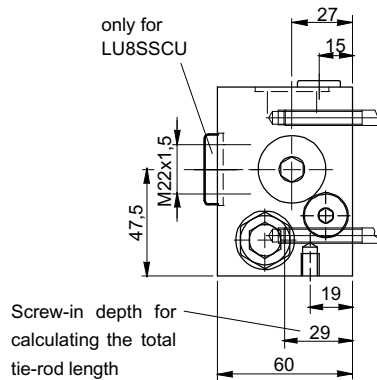

only for LU8SSCU

Screw-in depth for calculating the total tie-rod length

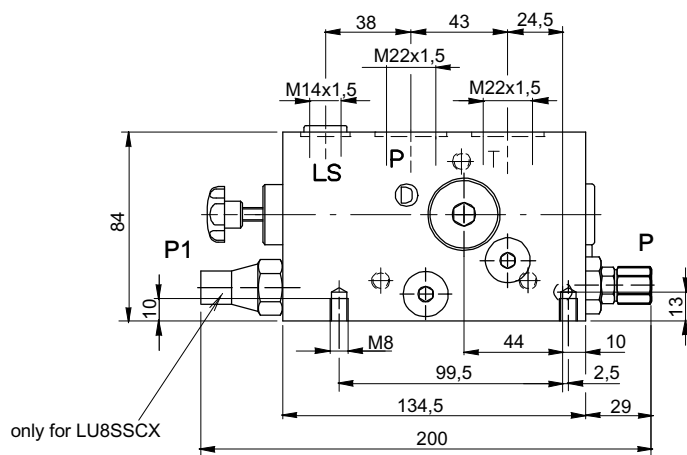

only for LU8SSCX

### 4 Intermediate sections

#### 4.1 Intermediate sections with no control function

##### 4.1.1 Description

These intermediate sections are used as spacer section (e.g. with large port fittings) or, in the case of the LU8SBTP-0; for hydraulic partitioning of the P and LS lines within the valve block; T is continuous.

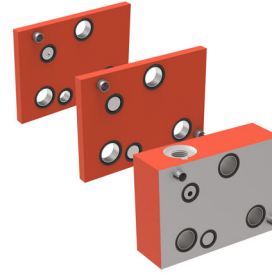

##### 4.1.2 Overview of sections

Symbol	Description	Part number
	<b>LU8SBDP-0*00</b> <ul style="list-style-type: none"> <li>• block spacer section</li> <li>• P, T and LS continuous</li> </ul>	<b>100020651</b>
	<b>LU8SBTP-0*00</b> <ul style="list-style-type: none"> <li>• block partition section</li> <li>• P and LS blocked, T continuous</li> </ul>	<b>100020652</b>
	<b>LU8SBTL-0M14*00</b> <ul style="list-style-type: none"> <li>• block partition section</li> <li>• P blocked, T continuous, LS in front half of block to T, in rear half to separate LS port.</li> <li>• port threads to DIN 3852 - M14 x 1,5</li> </ul>	<b>100024522</b>

##### 4.1.3 Dimensions

###### 4.1.3.1 LU8SBDP / BTP

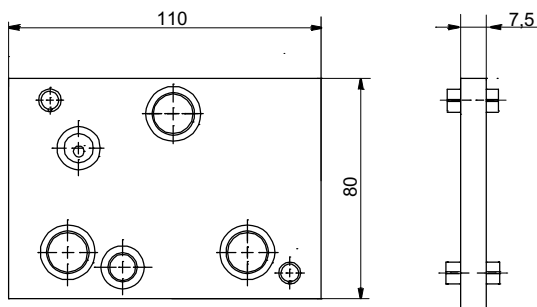

###### 4.1.3.2 LU8SBTL

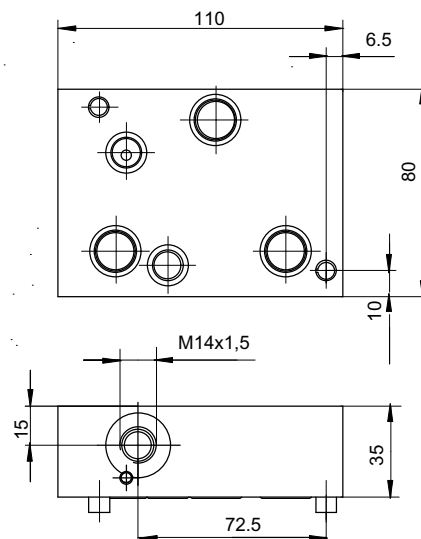

## 4.2 Intermediate sections with 2-way pressure compensator

### 4.2.1 Description

These are intermediate sections with an integral 2-way compensator, optionally with flow cut-off from a pre-set pressure. Typical applications: valve block sections that, in general, experience lower pressures are combined with this compensator to ensure load-independent operation. Ports P and LS are provided.

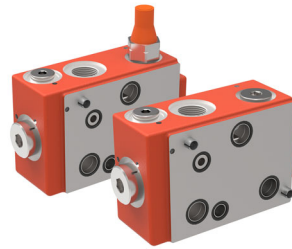

### 4.2.2 Technical data

General characteristics	Unit	Description, value
Inlet pressure	bar	max. 300
Nominal flow rate	l/min	see performance graphs 4.2.3
Pressure relief valve	bar	adjustable

### 4.2.3 Performance graphs

#### 4.2.3.1 Variation of the actuator flow rate with inlet pressure when using an LU8SSKC / SKD intermediate section

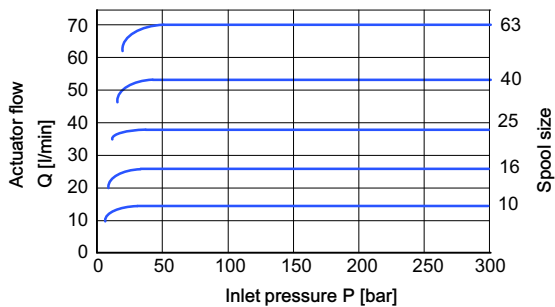

#### 4.2.3.2 Flow cut-off function with an LU8SSKD intermediate section

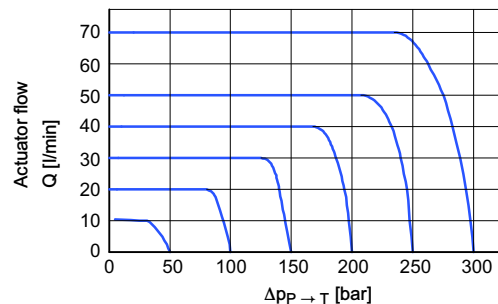

### 4.2.4 Overview of sections

Symbol	Description	Part number
	<b>LU8SSKC-0M22*00</b> <ul style="list-style-type: none"> <li>nominal flow rate 100 l/min</li> <li>port threads to DIN 3852 - M22 x 1,5</li> </ul>	<b>100021341</b>
	<b>LU8SSKD-0M22*00/P=</b> <ul style="list-style-type: none"> <li>nominal flow rate 100 l/min</li> <li>with adjustable pressure relief valve for flow cut-off</li> <li>port threads to DIN 3852 - M22 x 1.5</li> </ul> ⇒ Specify the pressure relief setting in bar. (50 ... 300 bar)	see order details chapter 1.1

### 4.2.5 Dimensions

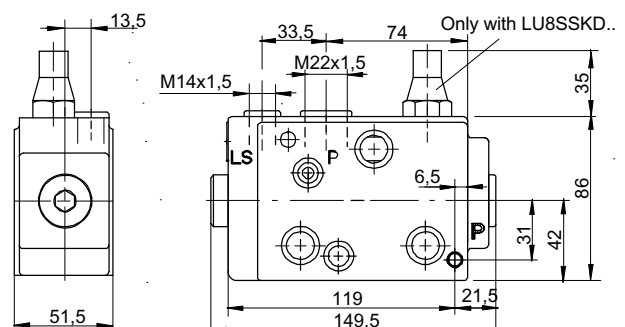

### 4.3 Intermediate sections with 3-way pressure compensator

#### 4.3.1 Description

These 3-way compensators are intermediate sections with the additional functions shown below. In essence, they can be applied in conjunction with a fixed-displacement pump for control of unloading, and flow control that is independent of the load. Ports P, and D and LS as appropriate, are provided.



#### 4.3.2 Function

- **LU8SSBU**  
Provides a 3-way compensator function with 2-stage pressure relief, and a reduction in the unloaded pressure from the standard 12 bar to approx. 6 bar.
- **LU8SSBK**  
Includes a 3-way compensator function with the facility to change over to LS or constant-pressure systems. This is typical with towed harvesters.

- **LU8SSBW**  
Provides a 3-way compensator function and the surplus flow is available at port D or internally for other applications. Both flows are protected by a two-stage pressure relief valve. On reaching the maximum pressure in the priority side, which can then be loaded up to the maximum pressure setting.

#### 4.3.3 Technical data

General characteristics	Unit	Description, value
Inlet pressure <sup>1)</sup>	bar	max. 300
Nominal flow rate	l/min	120
Unloaded pressure P → T (LU8SSBU/SBT/SBL/SBK)	bar	see performance graphs chapter 4.3.4
Pressure relief	bar	adjustable, 50 ... 300 bar
Nominal voltage <sup>2)</sup>	V DC	12 or 24
Plug type		AMP Junior Timer, DT04-2P-EP04
Power consumption <sup>2)</sup>	Watt	27
Duty cycle <sup>2)</sup>	%	100
Protection class <sup>2)</sup>		AMP: IP65                      DT: IP67 (DIN EN 60529)

1) Inlet pressure for LU8SSBU-....G.. and LU8SSBW....G.. max. 250 bar.

2) Only with electrical unloading.

#### 4.3.4 Performance graphs

##### 4.3.4.1 Unloaded pressure in neutral position, LU8SSBW

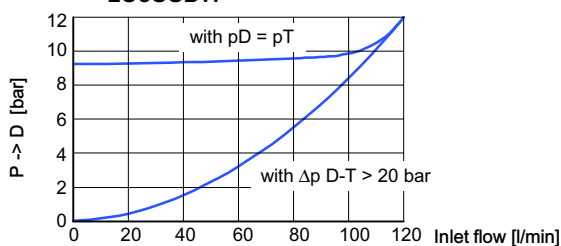

##### 4.3.4.3 Pressure relief characteristic, LU8SSB

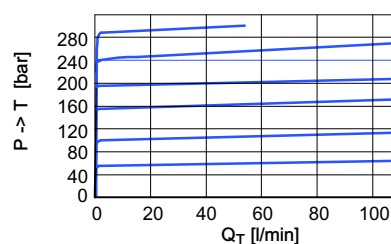

##### 4.3.4.2 Maximum flow rate at directional valve (without individual pressure compensator) when using a LU8SSBU / LU8SSBW

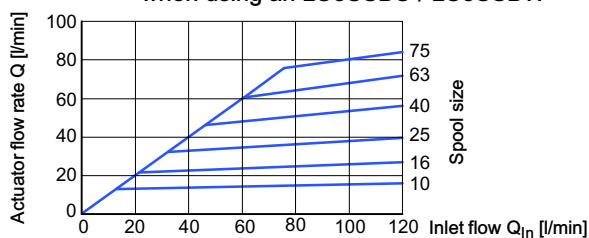

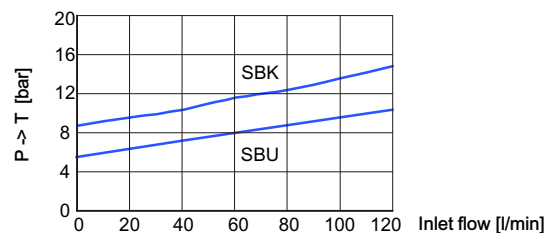

##### 4.3.4.4 Unloaded pressure in neutral position, LU8SSBU / LU8SSBK

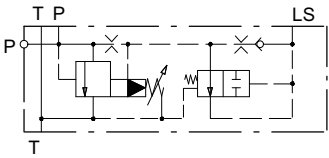
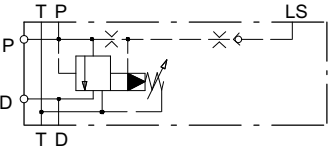
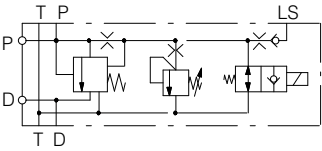
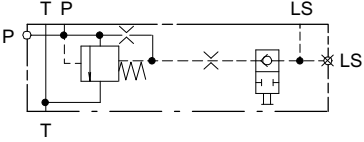

## 4.3.5 Overview of sections

Symbol	Description	Part number
	<b>LU8SSBU-0M22*00/P=</b> <ul style="list-style-type: none"> <li>with two-stage pressure relief / control <math>\Delta p = 12</math> bar</li> <li>reduction in the unloaded pressure to approx. 6 bar</li> <li>port threads to DIN 3852 - M22 x 1,5</li> </ul> ⇒ Specify the pressure relief setting in bar	see order details chapter 1.1
	<b>LU8SSBW-0M22*00/P=</b> <ul style="list-style-type: none"> <li>with two-stage pressure relief / with surplus flow port</li> <li>control <math>\Delta p = 12</math> bar</li> <li>port threads to DIN 3852 - M22 x 1.5</li> </ul> ⇒ Specify the pressure relief setting in bar	see order details chapter 1.1
	<b>LU8SSBW-0M22T24*00/P=</b> <ul style="list-style-type: none"> <li>with two-stage pressure relief / with surplus flow port</li> <li>control <math>\Delta p = 12</math> bar / emergency stop function</li> <li>port threads to DIN 3852 - M22 x 1.5</li> <li>plug type to DIN 43650 (others on enquiry) / nominal voltage 24 V DC</li> </ul> ⇒ Specify the pressure relief setting in bar	see order details chapter 1.1
	<b>LU8SSBK-0M22*00</b> <ul style="list-style-type: none"> <li>compensator can be disabled for LS systems</li> <li>control <math>\Delta p = 12</math> bar with active pressure compensator</li> <li>without pressure relief</li> <li>port threads to DIN 3852 - M22 x 1.5</li> </ul>	100020654

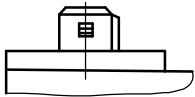
## 4.3.6 Connector socket

AMP Junior Timer J	Deutsch plug DT04-2P-EP04 T
	

## 4.3.7 Dimensions

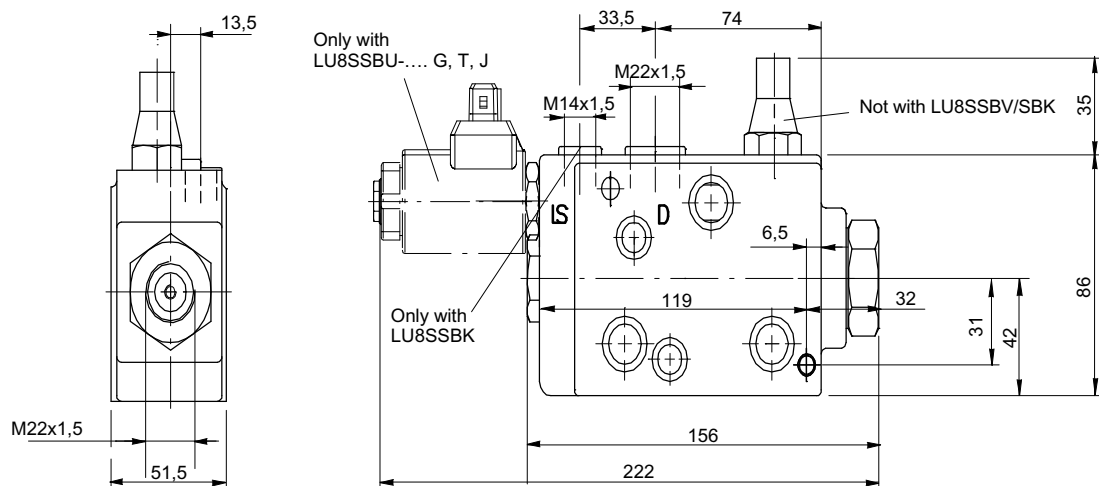

## 4.4 Intermediate sections with priority function

### 4.4.1 Description

The LU8SSB-0... priority sections contain a priority function for the directional valves fitted on the appropriate side or for an external control system and a surplus flow side.

In an under-supply scenario (pump flow < total flow needed by the valve block), the surplus flow side will receive only a portion of what it needs, or possibly (pump flow < priority-flow setting) no flow what ever. Preferred applications are in LS-systems. The priority side can also be equipped with a pressure relief valve that ensures a priority-flow cut-off when the pressure setting is reached.

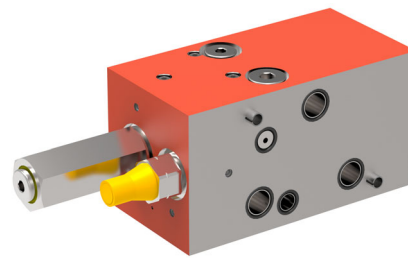

For oscillation-prone applications, a damping element (e.g. an accumulator) can be connected to a port specially (M14x1,5) provided for this purpose.

### 4.4.2 Technical data

General characteristics	Unit	Description, value
Inlet pressure	bar	max. 300
Nominal flow rate	l/min	120
Unloaded pressure P -> T	bar	see performance graphs 4.4.3
Pressure for flow cut-off ( $P_{Priority}$ )	bar	adjustable, 50 ... 300 bar

### 4.4.3 Performance graphs

#### 4.4.3.1 Flow cut-off on the priority side

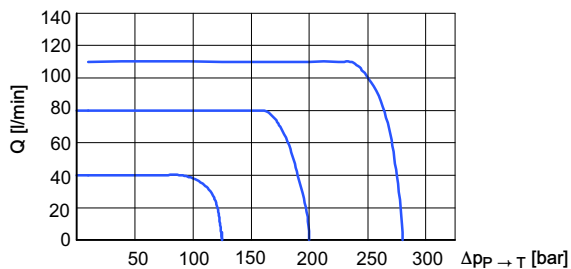

#### 4.4.3.2 Pressure drop characteristic

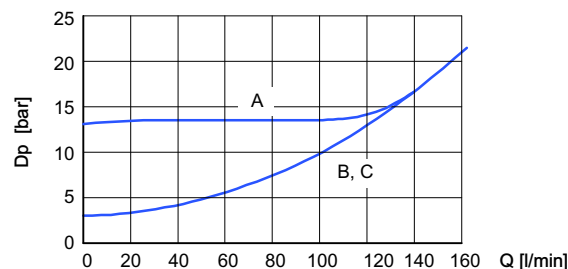

A =  $P_{pump}$  port to  $P_{Surp}$  ( $Q_{Priority}=zero$ ) at  $P_{Surp} = P_{LS}$   
 B =  $P_{pump}$  port to  $P_{Surp}$  at  $\Delta p_{P_{Surp}}$  to LS > 20 bar  
 C =  $P_{pump}$  port to  $P_{Priority}$  (control spool in neutral position)

### 4.4.4 Overview of sections

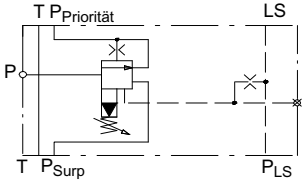
Symbol	Description	Part number
	<b>LU8SSBP-0M26*00/P=</b> • with flow cut-off / port threads to DIN 3852 - M26 x 1,5 ⇒ Specify the pressure relief setting in bar, (50 ... 300 bar)	see order details chapter 1.1
	<b>LU8SSBP-0B10*00/P=</b> • with flow cut-off / port threads to BSP 1" / G 1" ⇒ Specify the pressure relief setting in bar (50 ... 300 bar)	see order details chapter 1.1

### 4.4.5 Dimensions

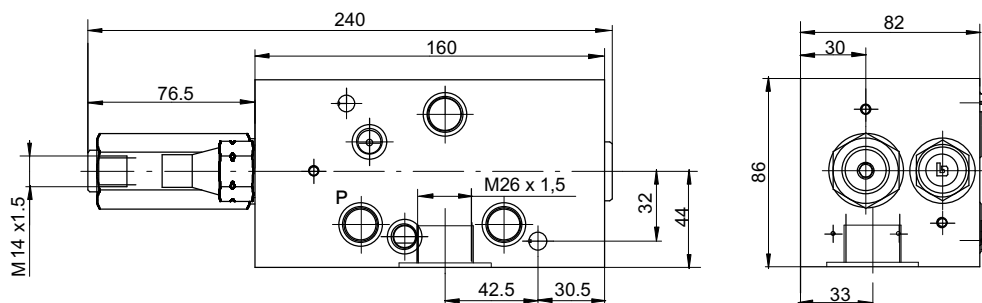

## 4.5 Intermediate sections with multi-way pressure compensator

### 4.5.1 Description

The multi-way pressure compensators contain a priority function for the directional valves fitted on the appropriate side. For the surplus-flow side, a 3-way pressure compensator is available for unloading control and load-independent flow control when using a fixed displacement pump.

In the under-supply range (pump flow < total flow needed by the valve block), the surplus flow side will receive only a portion of what it needs, or possibly (pump flow < priority flow setting) no flow whatsoever.

Application preferably in conjunction with a fixed displacement pump, but with the ability to change over to LS or constant-pressure systems.

Ports P, T, and LS are provided.

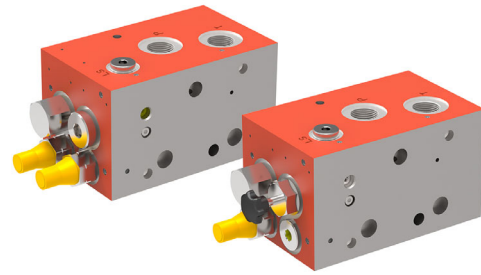

### 4.5.2 Functions

#### • LU8SSMD

Priority-flow control as 2- and 3-way compensator, with surplus-flow control as 3-way compensator. The priority-flow side is provided with a flow cut-off function, the surplus-flow side with two-stage pressure relief.

#### • LU8SSMF

Priority-flow control as 2- and 3-way compensator, with surplus-flow control as 3-way compensator. The priority-flow side is provided with a flow cut-off function. The surplus-flow control can be de-activated, which allows an LS- or constant-pressure system to be connected. This is typical with towed harvesters.

### 4.5.3 Technical data

General characteristics	Unit	Description, value
Inlet pressure	bar	max. 300
Nominal flow rate	l/min	120
Unloaded pressure	bar	see performance graphs section 4.5.4
Pressure for flow cut-off ( $P_{\text{Priority}}$ )	bar	adjustable, 50 ... 300 bar
Pressure for pressure relief ( $P_{\text{Surp}}$ )	bar	adjustable, 50 ... 300 bar

### 4.5.4 Performance graphs

#### 4.5.4.1 Maximum flow rate at directional valve when using an LU8SSM. (priority- and surplus side).

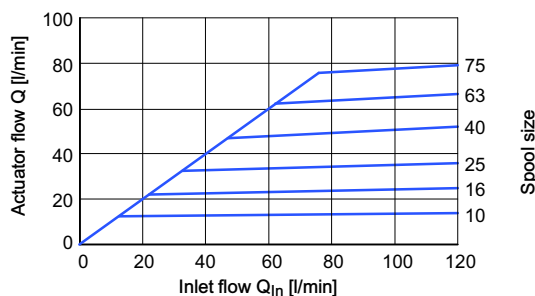

#### 4.5.4.2 Flow cut-off on the priority side

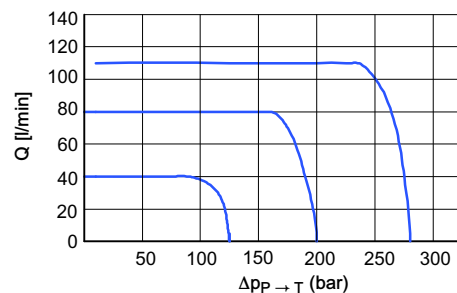

## 4.5.4.3 Pressure relief characteristic (priority and surplus flow) LU8SSM.

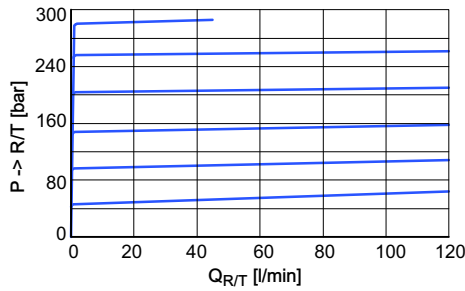

## 4.5.4.4 Unloaded pressure in neutral position LU8SSM.

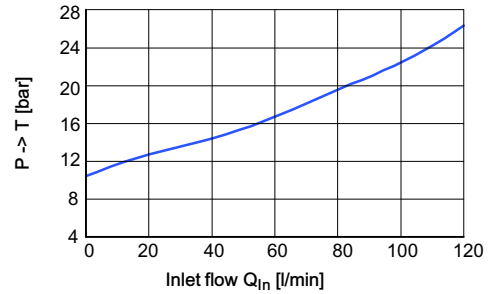

## 4.5.5 Overview of sections

Symbol	Description	Part number
	<b>LU8SSMD-0M22*00/P1=P2=</b> <ul style="list-style-type: none"> <li>• P<sub>Prior</sub> with two-stage pressure relief</li> <li>• P<sub>Surp</sub> with two-stage pressure relief</li> <li>• control <math>\Delta p = 12</math> bar for P<sub>Prior</sub> and P<sub>Surp</sub></li> <li>• port threads to DIN 3852 - M22 x 1,5</li> </ul> ⇒ Specify the pressure relief setting in bar	see order details chapter 1.1
	<b>LU8SSMF-0M22*00/P=</b> <ul style="list-style-type: none"> <li>• P<sub>Prior</sub> with pressure relief</li> <li>• compensator can be disabled on surplus-flow side for LS systems</li> <li>• control <math>\Delta p = 12</math> bar for P<sub>Prior</sub></li> <li>• control <math>\Delta p = 12</math> bar for P<sub>Surp</sub> with active pressure compensator</li> <li>• port threads to DIN 3852 - M22 x 1,5</li> </ul> ⇒ Specify the pressure relief setting in bar	see order details chapter 1.1

## 4.5.6 Dimensions

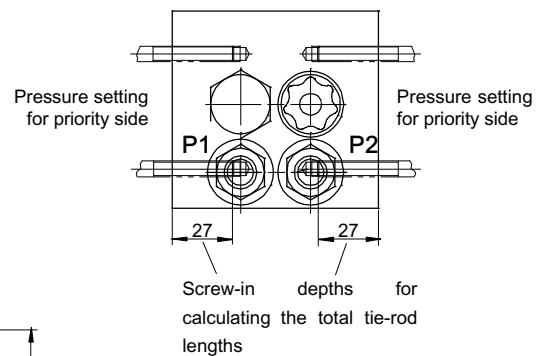
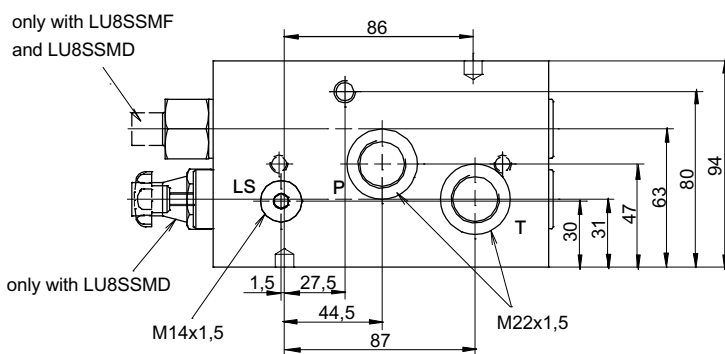
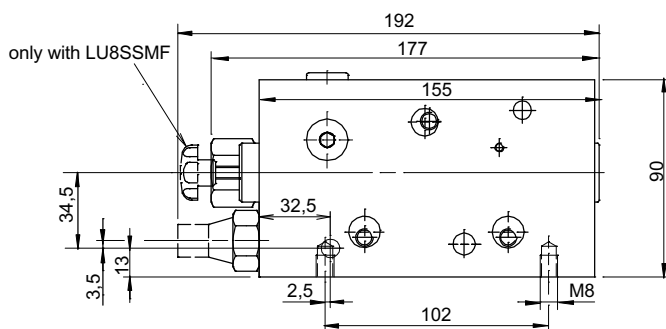

## 4.6 Intermediate section with proportional pressure reducing valve

### 4.6.1 Description

The 3-way pressure reducing valve holds the pressure at the actuator port at a constant level, as set by the solenoid current. Via the LS-feedback, this function can work with all pressure compensators and pump systems. The relevant additional functions are described below.

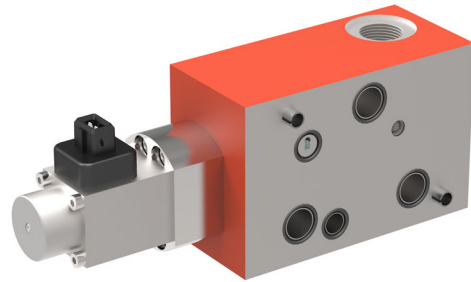

### 4.6.2 Functions

- LU8SPDRZ\*-06AS-...  
3-way pressure reducing valve, minimum actuator pressure 8 ... 20 bar.
- LU8SPDRZ\*-06BS-...  
3-way pressure reducing valve, minimum actuator pressure 8 ... 20 bar, has a seat valve for leak-free shut-off of the load.

### 4.6.3 Technical data

General characteristics	Unit	Description, value
Primary pressure $P_{max}$	bar	max. 300
Secondary pressure $P_{Red}$ (as per pressure range)	bar	40, 100, 160, 250
Nominal flow rate $Q_{max}$	l/min	40 for LU8SPDRZ*-06BS-... / 25 for LU8SPDRZ*-06CS
Port thread		DIN 3852 - M18 x 1,5 / M22 x 1,5
Power consumption: pressure reducing valve solenoid x	Watt	20 27
Nominal voltage pressure reducing valve	V DC	12 (24 on enquiry)
Plug type		DIN 43650
Solenoid current $I_{min}$ $I_{max}$	A	0,25 or 0,13 ±10% 1,90 or 0,95 ±10%
Enclosure protection		AMP: IP65 DT: IP67 (DIN EN 60529)
Connector socket		DIN 43650

### 4.6.4 Performance graphs

#### 4.6.4.1 Control characteristic $P_{reduced} = f(I_{solenoid})$

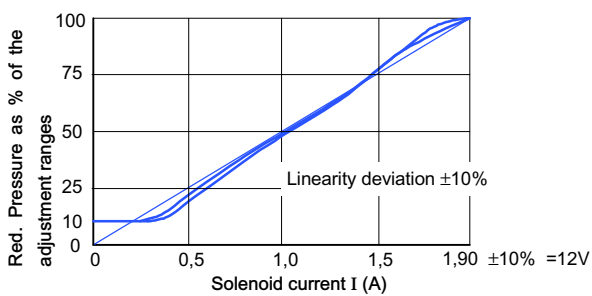

#### 4.6.4.3 Control characteristic as a function of the flow rate

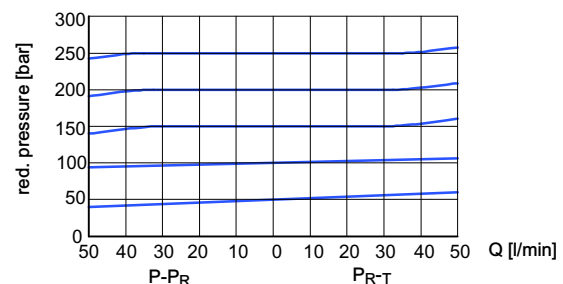

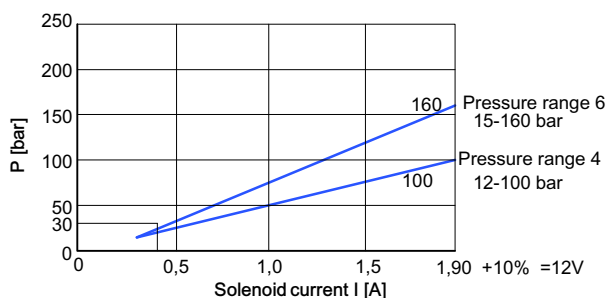

#### 4.6.4.2 Adjustment ranges 3-way pressure control valve

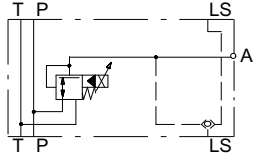
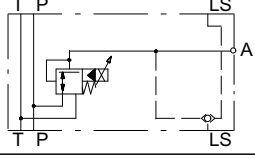

### 4.6.5 Overview of sections

Symbol	Description	Part number
	<b>LU8SPDRZ*-06AS4-1M22J12*01</b> <ul style="list-style-type: none"> <li>• solenoid operated</li> <li>• pressure range 12 ... 100 bar</li> <li>• port threads to DIN 3852 M22 x 1,5</li> </ul>	<b>100040972</b>
	<b>LU8SPDRZ*-06AS6-1M22J12*01</b> <ul style="list-style-type: none"> <li>• solenoid operated</li> <li>• pressure range 15 ... 160 bar</li> <li>• port threads to DIN 3852 M22 x 1,5</li> </ul>	<b>100042074</b>

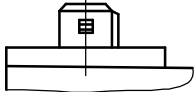
### 4.6.6 Connector socket

AMP Junior Timer J	DT04-2P-EP04 T
	

### 4.6.7 Dimension

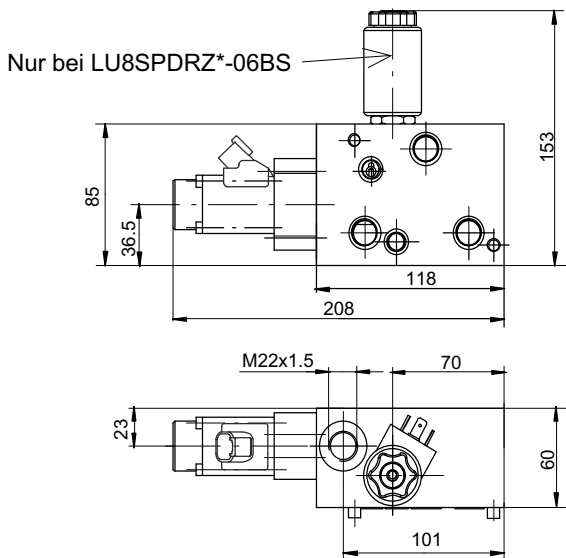

## 5 Directional valves

### 5.1 LA8S-/ LF8S- Directional valves

#### 5.1.1 Description

These directional valve sections, operated by hand lever or remote cable, are distinguished by their adaptability. Auxiliary functions can be bolted on above the valve. To enable this, the appropriated interfaces must be chosen (see the following illustrations).

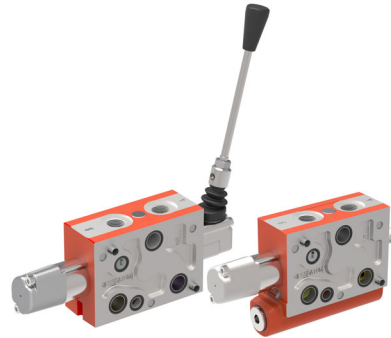

#### 5.1.1.1 Integral auxiliary functions

- **Individual pressure compensator**

The integral 2-way pressure compensator maintains a constant pressure differential over the metering orifice in the directional valve spool. This means that the corresponding actuator flow remains constant and load-independent even if another actuator that needs a higher pressure is operated at the same time.

- **Flow cut-off**

Thanks to the adjustable maximum pressure, the actuator flow rate is reduced to zero when the level is exceeded. The corresponding function therefore stops until the actuator pressure has fallen to the permissible pressure range.

#### 5.1.2 Function

##### 5.1.2.1 LA8S

Operated by hand lever

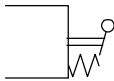

##### 5.1.2.2 LA8S

Operated by remote cable



#### 5.1.3 Technical data

General characteristics	Unit	Description, value
Inlet pressure	bar	max. 300
Actuator pressure duty cycle = 10 s/min	bar	max. 315
Spool size	l/min	10, 16, 25, 40, 60 <sup>1)</sup>
Operating force on the spool	N	170 ... 210

1) Higher flow rates on enquiry.

### 5.1.4 Overview of sections

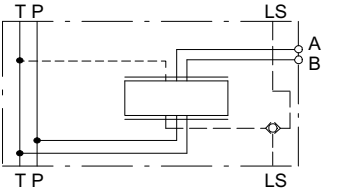
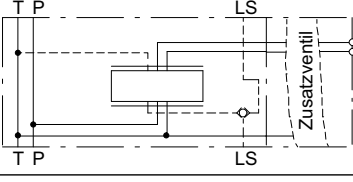
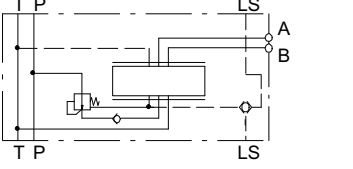
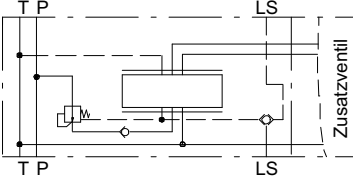
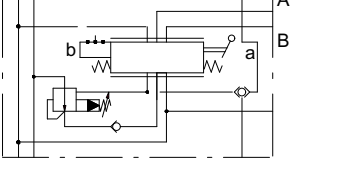
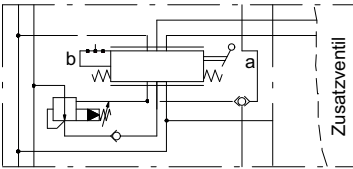
Symbol	Description	Part number
	<b>L.8SE.....-.*O-....</b> <ul style="list-style-type: none"> <li>port thread for actuator A and B</li> </ul>	see ordering code
	<b>L.8SE.....-.MO-....</b> <ul style="list-style-type: none"> <li>for bolt-on auxiliary valves on flange face O</li> </ul>	see ordering code
	<b>L.8SM.....-.*I-....</b> <ul style="list-style-type: none"> <li>with port thread for actuator A and B</li> <li>integrated pressure compensator</li> </ul>	see ordering code
	<b>L.8SM.....-.MI-....</b> <ul style="list-style-type: none"> <li>for bolt-on auxiliary valves on flange face O</li> <li>integrated pressure compensator</li> </ul>	see ordering code
	<b>L.8SM.....-F*L-....</b> <ul style="list-style-type: none"> <li>with port thread for actuator A and B</li> <li>spring return, flow cut-off</li> <li>integrated pressure compensator</li> </ul>	see ordering code
	<b>L.8SM.....-FML-....</b> <ul style="list-style-type: none"> <li>for bolt-on auxiliary valves on flange face O</li> <li>spring return, flow cut-off</li> <li>integrated pressure compensator</li> </ul>	see ordering code

## 5.1.5 Performance graphs

### 5.1.5.1 Maximum flow rate at directional valve (without compensator), LS-function

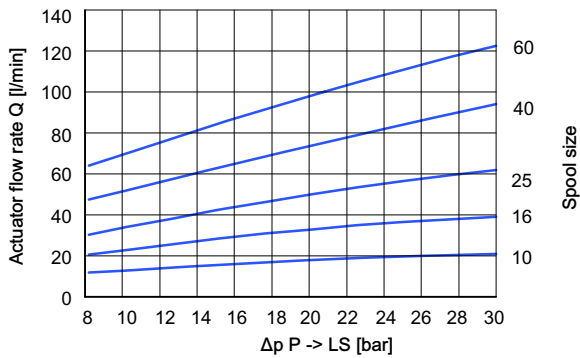

### 5.1.5.3 Pressure drop A/B → T

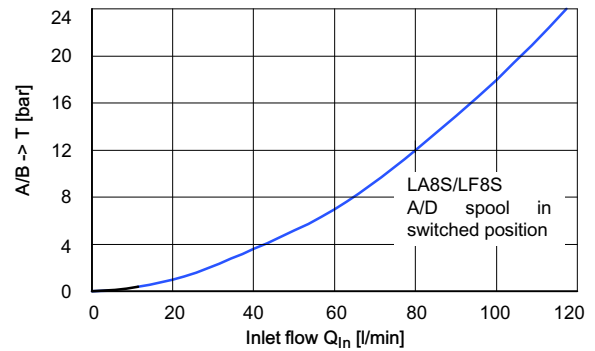

### 5.1.5.2 Flow characteristic with individual pressure compensator at flange face U

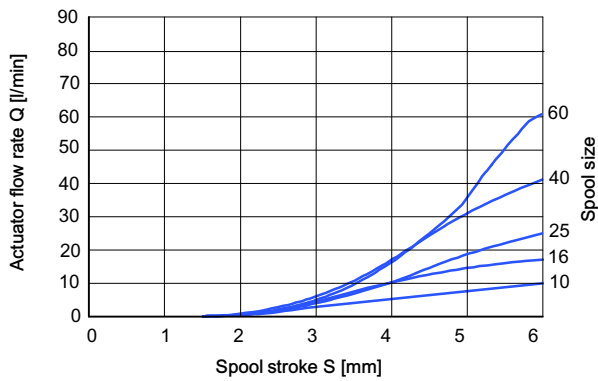



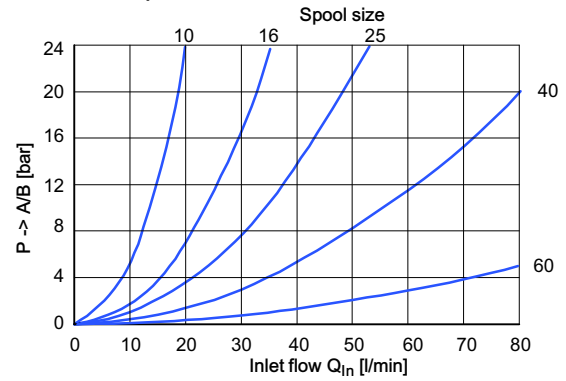







### 5.1.5.4 Pressure drop P → A/B (L.8S-directional valve), without pressure compensator, spool at maximum stroke

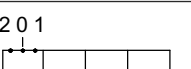
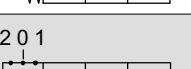

### 5.1.6 Overview spool position control

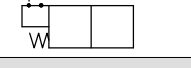
The purpose of the spool position controls and their variants is to optimise the spool-operation logic, and they should be

employed to make the user's task simpler. The various types are described below.

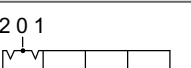
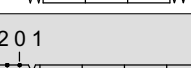
Spool position control type	Spring return from switch position		Detent function in switch position			Friction detent in switch position	
	1	2	1	2	3	1	2
A 		√	√				
B 	√			√			
C 	√						√
D 						√	√
E 						√	
F 	√	√					
G 	√						
J 			√				
L 	√	√			√		
M 			√	√	√		
R 			√	√			
T 		√	√		√		
U 	√			√	√		

**Spring return:** The spool returns to position 0 automatically.

**Detent function:** The spool is held at position 0; at maximum stroke it is also held in the respective position.

**Friction detent:** A detent hold can be felt at position 0; at any other position a friction device restrains the spool.

## 5.1.7 Option menu for ordering code (ordering code see section 5.1.8)

Spool type (way function, spool function, spool size in l/min)

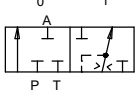
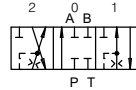
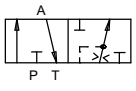
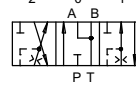
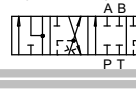
 <p>3I</p>	<p>10 l/min 16 l/min 25 l/min 40 l/min 60 l/min</p>	 <p>4A</p>	<p>10 l/min 16 l/min 25 l/min 40 l/min 60 l/min</p>
 <p>3J</p>			
		 <p>4D</p>	
		 <p>4K</p>	

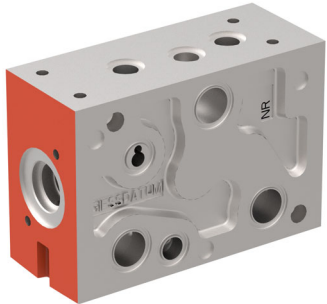

<b>Control type</b>	hand lever = LA8S
	remote cable = LF8S
<b>Operation</b>	load-independent individual operation = E
	load-independent parallel operation = M
<b>Attachment to flange face O</b>	port threads for line connections = *
	flange face for auxiliary valve = M

<b>Compensator function:</b>	
without pressure compensator	= O
with integrated pressure compensator	= I
with pressure compensator and flow cut-off	= L
with flow limiter (SDR)	= D

<b>Type of connection at face O</b>	
Flange face to factory standard	= ***
Line connection at ports A and B:	
Ex. DIN 3852 - M18 x 1,5	= M18
M22 x 1,5	= M22

## 5.1.8 Dimensions

### 5.1.8.1 Switch positions LF8S

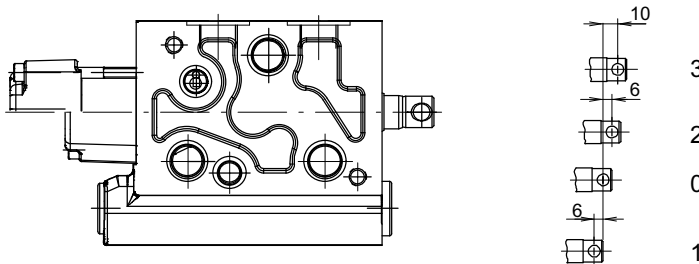

### 5.1.8.2 LF8S-directional valve

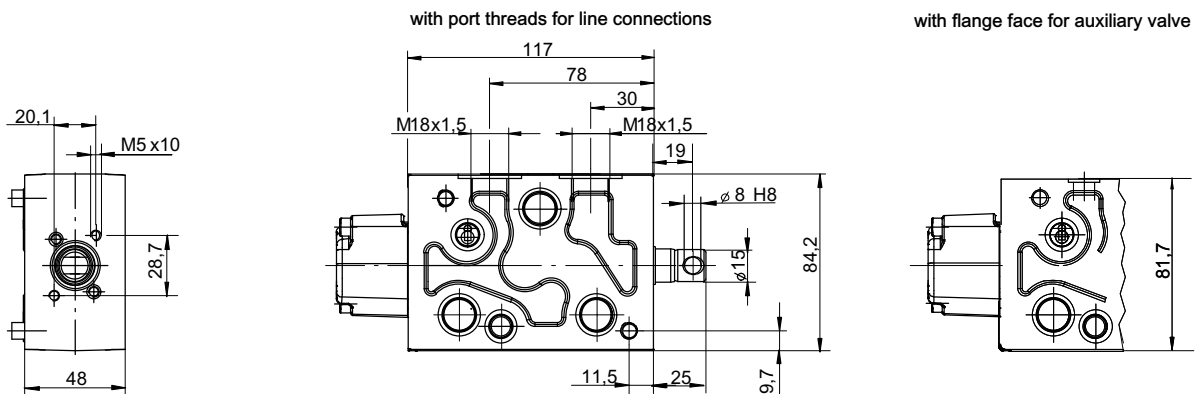

### 5.1.8.3 LF8S-directional valve with integrated pressure compensator

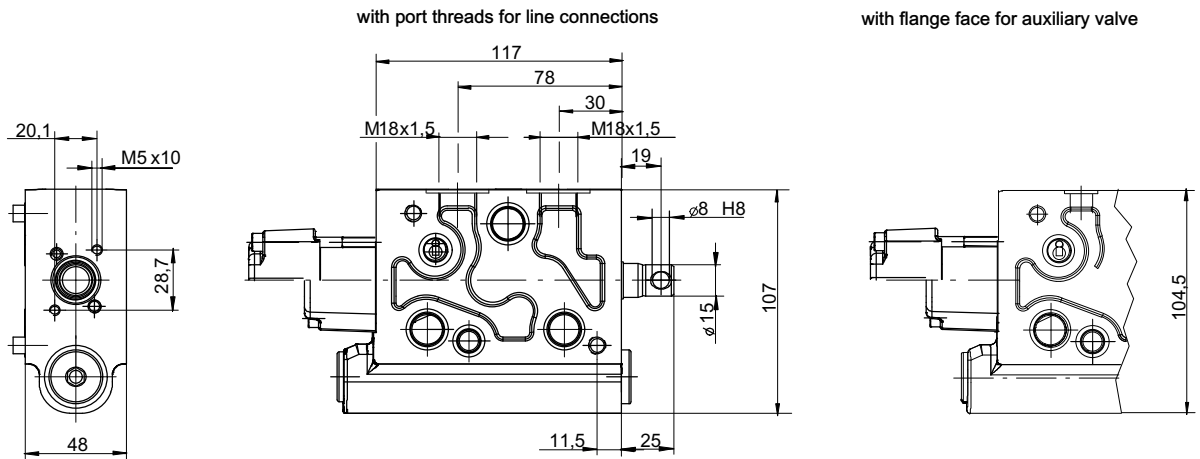

### 5.1.8.4 LA8S-directional valve

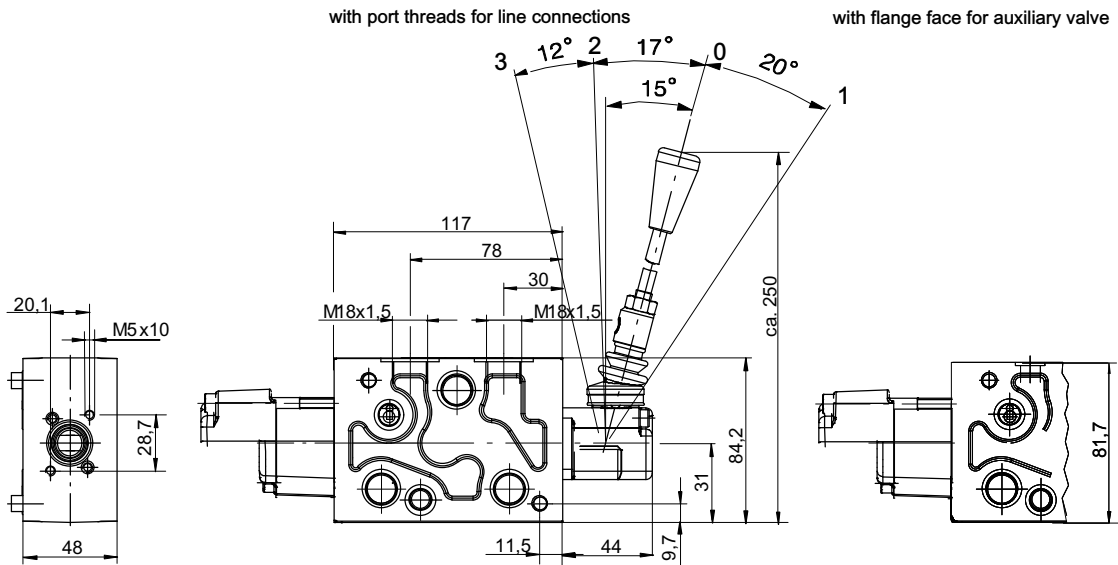

### 5.1.8.5 LA8S-directional valve with integrated pressure compensator

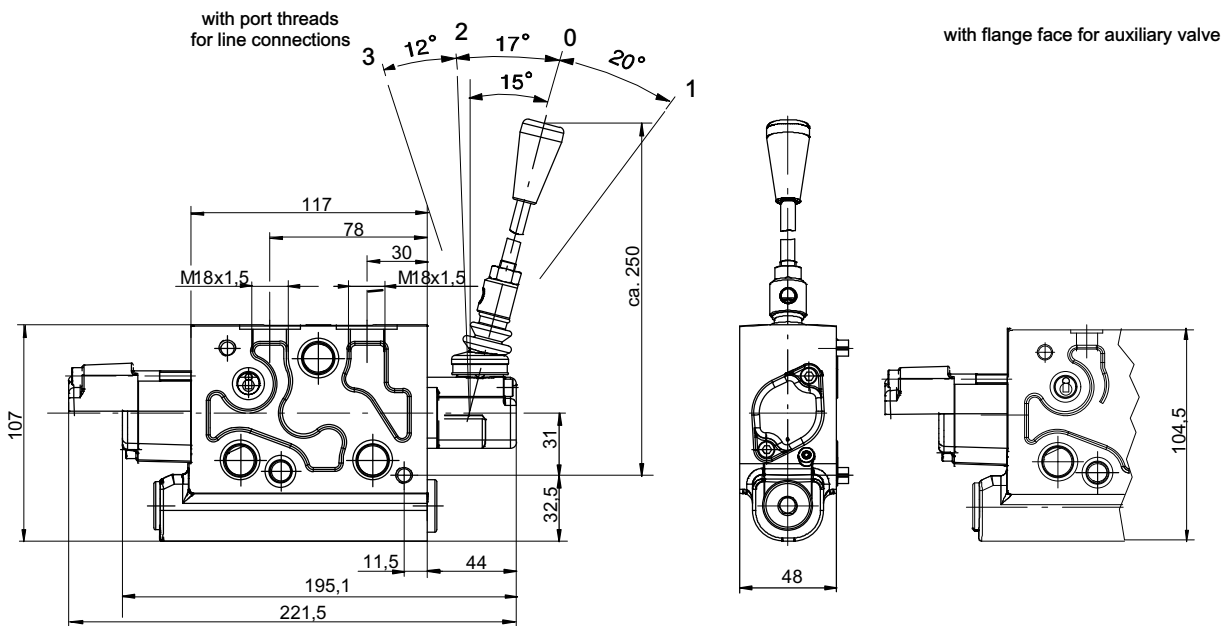

## 5.1.8.6 LA8S-directional valve with integrated pressure compensator and flow cut-off

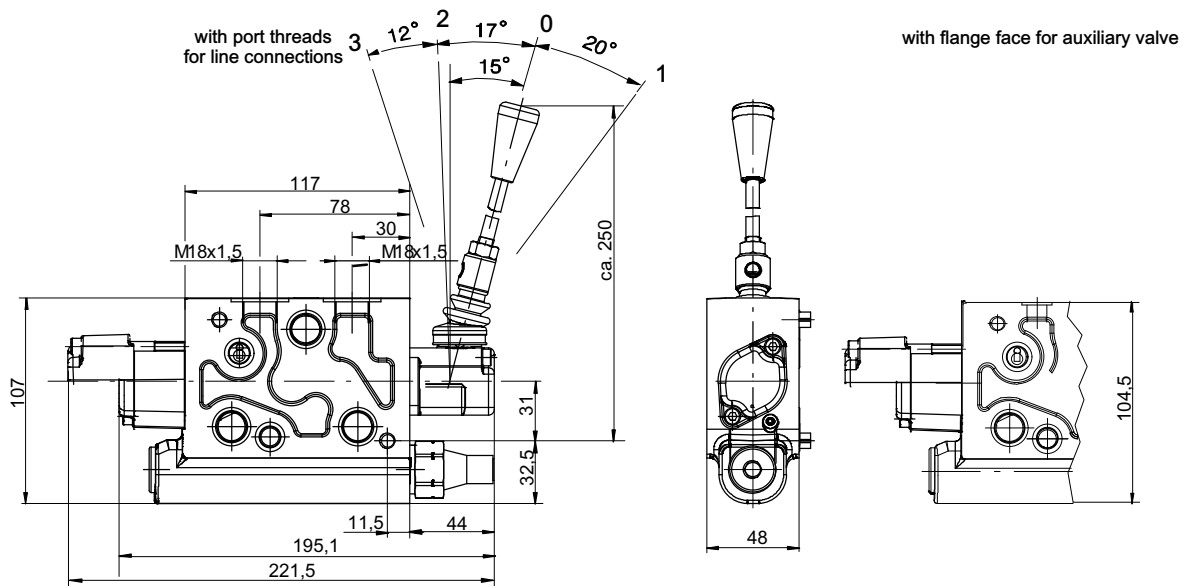

### 5.1.9 Ordering code LA8S... / LF8S...

- White fields = data specified by Bucher Hydraulics
- Grey fields = fill out the fields according the option menu 5.1.6 and the spool position overview 5.1.7

L
A
8
S
E
4
A
1
0
1
0
-
F
\*
O
-
1
M
1
8
\*
 

<b>Hand lever</b>	= LA8S		
<b>Remote operation</b>	= LF8S <sup>1)</sup>		
<b>Load-independent individual operation</b>	= E		
<b>Load-independent parallel operation</b>	= M		
<b>3-way function</b>	= 3		
<b>4-way function</b>	= 4		
<b>Spool function</b>	= A, D, I, J, K		
<b>Port A spool code:</b>	10, 16, 25, 40, 60 <sup>2)</sup>	= e.g. 10	
<b>Port B spool code:</b>	with 3-way function = **		
	with 4-way function 10,16,25,40,60 <sup>2)</sup> = e.g. 10 <sup>1)</sup>		
<b>Spool position control</b> (overview see section 5.1.5)	= e.g. A		
<b>Attachment to flange face O</b>	port threads for line connection = *		
	flange face for auxiliary valves = M		
<b>Compensator function:</b>	without pressure compensator = O		
	with integrated pressure compensator = I		
	with pressure compensator and flow cut-off = L		
	with flow limiter (SDR) = D		
<b>Design stage</b>	(to be inserted by Bucher Hydraulics)		
<b>Type of connection at face O:</b>	flange face to factory standard = ***		
	line connection to port A and B: DIN 3852 - M18 x 1,5 = M18		
	DIN 3852 - M22 x 1,5 = M22		
<b>Option</b>	(to be inserted by Bucher Hydraulics)		

1) When fitting the cable actuator 200.9609.0003.0, the special version LF8S...\*17 must be selected.

2) For higher flow rates, please enquire.

### 5.2 LD8S-/ LC8S- Directional valves

#### 5.2.1 Description

These directional valve sections with direct-acting ON/OFF solenoid or proportional solenoid are distinguished by their adaptability. Auxiliary functions can be bolted on above or below the valve. To enable this, the appropriate interfaces must be chosen (see following illustrations).

It is possible to set either the opening point of the control spool, or any predetermined point on the characteristic.

In the version with an additional manual operator, the flow rate can be increased.

The setting of the additional manual operator has no effect on the electrical operation. During electrical operation, the additional manual operator is not carried along with the solenoid mechanism. The lever remains in its neutral position, and thus has no influence on the spool characteristic.



##### 5.2.1.1 Integral auxiliary functions

- **Individual pressure compensator**

The integral 2-way pressure compensator maintains a constant pressure differential over the metering orifice in the directional valve spool. This means that the corresponding actuator flow remains constant and load-independent even if another actuator that needs a higher pressure is operated at the same time.

- **Flow cut-off**

Thanks to the adjustable maximum pressure, the actuator flow rate is reduced to zero when the level is exceeded. The corresponding function therefore stops until the actuator pressure has fallen to the permissible pressure range.

The pressure adjustment is manual, or optionally electro-proportional.

- **3-way pressure control**

Both a 3-way pressure control (P constant) and a flow control (Q constant) are incorporated in this valve section. The integral pressure control function can be switched to actuator port A or B, depending on the switching position of the valve section.

Below the pressure setting, the pressure-control assembly works as an individual pressure compensator and maintains a constant pressure differential over the metering orifice in the directional valve spool.

This means that the actuator flow rate is load-independent. For optimum 3-way pressure control, the corresponding directional function must be activated to its maximum extent.

Typical applications are actuating functions that are specifically speed-controlled, with the possibility of a holding or press function. This function can be controlled to any required pressure and can act optionally on either actuator A or B.

#### 5.2.2 Function

##### 5.2.2.1 LD8S with direct-acting ON/OFF solenoid

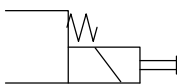

##### 5.2.2.2 LD8S with direct-acting ON/OFF solenoid, optional manual override for the valve spool

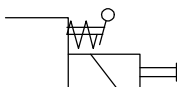

The flow rates to the A and B actuator ports are graded by spool size as per sections 5.2.4. Using the stop-screw on the non-active solenoid, each flow rate can be reduced from its maximum by a maximum of 50%.

##### 5.2.2.3 LC8S with direct-acting proportional solenoid

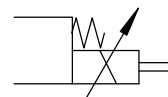

##### 5.2.2.4 LC8S with direct-acting proportional solenoid, optional manual override for the valve spool

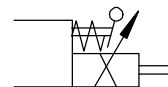

The flow rates to the A and B actuator ports are graded by spool size as per sections 5.2.4.

## 5.2.3 Technical data

General characteristics	Unit	Description, value	
		LD8S	LC8S
Type of operation		ON/OFF	Proportional
Inlet pressure	bar	250	
Actuator pressure (duty cycle 10 sec/min)	bar	max. 280	
Spool size	l/min	02, 05, 10, 16, 25, 40, 60	
Solenoid design		ON/OFF solenoid with mechanical manual override	Proportional solenoid with mechanical manual override
Nominal voltage	V DC	12 (10,8 ...14) 24 (21,6 ...28)	12 or 24
Power consumption at R <sub>20</sub>	Watt	22 (U <sub>N</sub> 12 V) 22 (U <sub>N</sub> 24 V)	max. 24 at 2,5 A (U <sub>N</sub> 12 V) max. 24 at 1,3 A (U <sub>N</sub> 24 V)
Duty cycle	%	100	100 at I <sub>max</sub> 2,5 A (U <sub>N</sub> 12 V) 1,3 A (U <sub>N</sub> 24 V)
Plug type		AMP Junior Timer DT04-2P-EP04	
Enclosure protection		AMP: IP65	DT: IP67 (DIN EN 60529)
Switch frequency	Hz	> 2 (please contact the factory)	
Accessories		For electronic controls see overview brochure 100-P-700069	

**IMPORTANT:** Maximum reduction is to 50% of the respective nominal spool size.

## 5.2.4 Performance graphs

### 5.2.4.1 Typical flow characteristic curve without compensator function (spool type 4D/4A to loop line A->B / B->A)

(Inlet section with 3-way press. compensator for  $\Delta p$  12 bar)

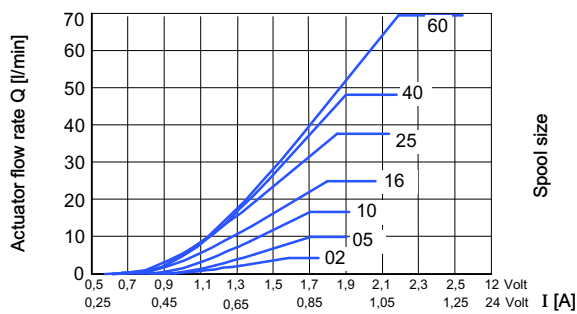

### 5.2.4.2 Typical flow characteristic curve with compensator function (spool type 4D/4A to loop line A->B / B->A)

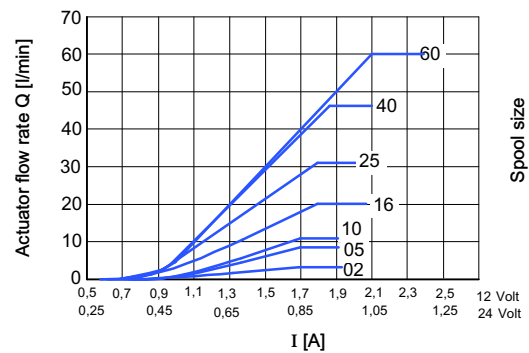

### 5.2.4.3 LD / LC Maximum flow rate at the directional valve without compensator function, LS-function

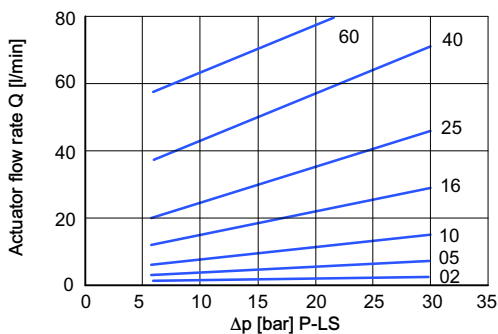

### 5.2.4.4 LC Pressure drop A/B -> T in the LC8SM4A directional stage

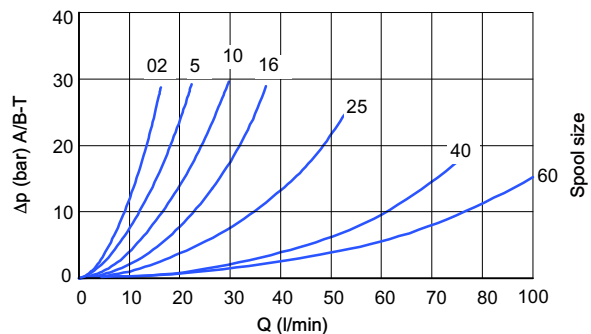

5.2.4.5 Typical flow characteristic curve with flow cut-off function, pressure relief adjustable (manual)

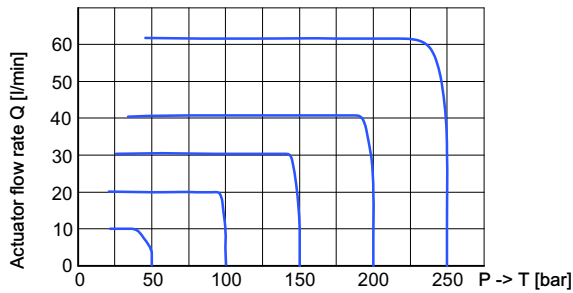

5.2.4.6 Typical flow characteristic curve with flow cut-off function, pressure relief adjustable (electroproportional)

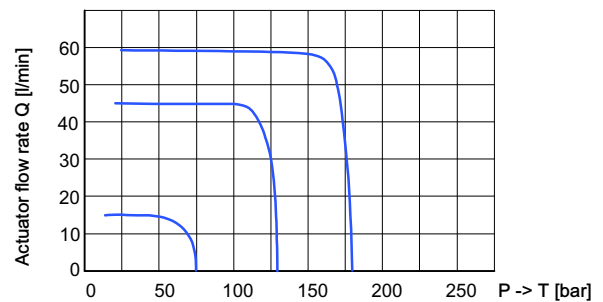

5.2.4.7 LC flow cut-off function pressure setting p - I (electr. prop.)

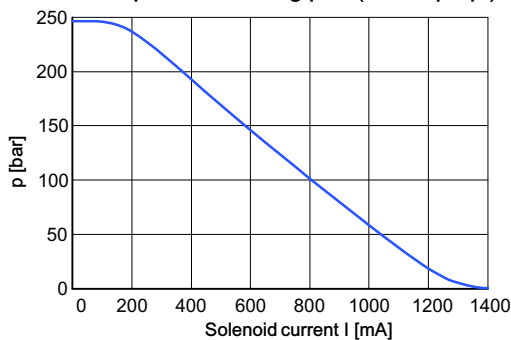

5.2.4.8 Typical pressure profile 3-way pressure control Electroproportional

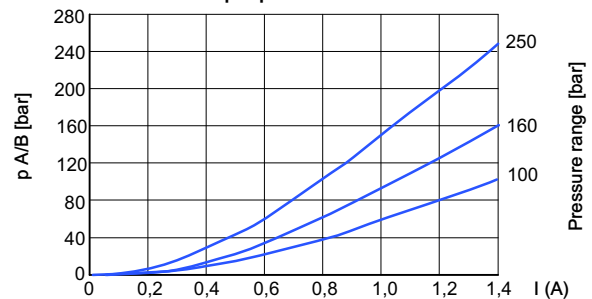

Inverse function possible – please enquire.

5.2.4.9 Typical pressure profile 3-way pressure control, Overall function

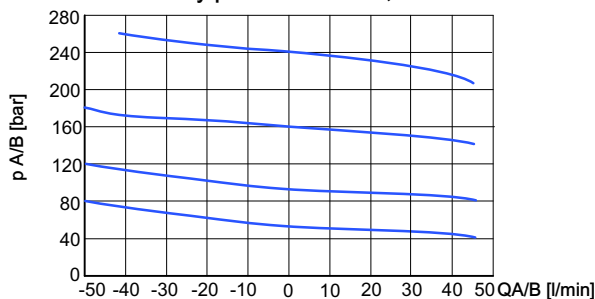

## 5.2.5 Overview of sections

### 5.2.5.1 LD8S / LC8S-directional valves with port threads

Symbol	Description	Part number
	<b>L.8SE.....-.*O-....</b> <ul style="list-style-type: none"> <li>port threads for actuator A and B</li> </ul>	see ordering code
	<b>L.8SM.....-.*I-....</b> <ul style="list-style-type: none"> <li>port threads for actuator A and B</li> <li>pressure compensator</li> </ul>	see ordering code

	<b>L.8SM.....-.*L-....</b>	see ordering code
	<ul style="list-style-type: none"> <li>• port threads for actuator A and B</li> <li>• flow cut-off</li> </ul>	
	<b>L.8SM.....-.*P-....</b>	see ordering code
	<ul style="list-style-type: none"> <li>• port threads for actuator A and B</li> <li>• pressure compensator</li> <li>• flow cut-off electroproportional</li> </ul>	
	<b>L.8SM.....-.4-....</b>	see ordering code
	<ul style="list-style-type: none"> <li>• port threads for actuator A and B</li> <li>• pressure compensator</li> <li>• 3-way pressure control</li> </ul>	

### 5.2.5.2 LD8S / LC8S-directional valves for bolt-on auxiliary valves

Symbol	Description	Part number
	<b>L.8SE.....-.MO-....</b>	see ordering code
	<ul style="list-style-type: none"> <li>• for bolt-on auxiliary valves on flange face O</li> </ul>	
	<b>L.8SM.....-.MI-....</b>	see ordering code
	<ul style="list-style-type: none"> <li>• for bolt-on auxiliary valves on flange face O</li> <li>• flow cut-off</li> </ul>	
	<b>L.8SM.....-.ML-....</b>	see ordering code
	<ul style="list-style-type: none"> <li>• for bolt-on auxiliary valves on flange face O</li> <li>• pressure compensator</li> <li>• flow cut-off</li> </ul>	
	<b>L.8SM.....-.MP-....</b>	see ordering code
	<ul style="list-style-type: none"> <li>• for bolt-on auxiliary valves on flange face O</li> <li>• integrated individual pressure compensator</li> <li>• flow cut-off, electroproportional</li> </ul>	
	<b>L.8SM.....-.M4-....</b>	see ordering code
	<ul style="list-style-type: none"> <li>• for bolt-on auxiliary valves on flange face O</li> <li>• pressure compensator</li> <li>• 3-way pressure control</li> </ul>	

## 5.2.6 Option menu for ordering code (ordering code see section. 5.2.9)

**Spool type (way function, spool function, spool size in l/min)**



<b>3A</b>  10 l/min 16 l/min 25 l/min 40 l/min 60 l/min	<b>3I</b>  05 l/min 10 l/min 16 l/min 25 l/min 40 l/min 60 l/min	<b>4A</b>  02 l/min 05 l/min 10 l/min 16 l/min 25 l/min 40 l/min 60 l/min	<b>4E</b>  16 l/min 25 l/min 40 l/min 60 l/min
<b>3J</b>  10 l/min 16 l/min 25 l/min 40 l/min 60 l/min	<b>4D</b>  02 l/min 05 l/min 10 l/min 16 l/min 25 l/min 40 l/min 60 l/min	<b>4F</b>  10 l/min 16 l/min 25 l/min 40 l/min 60 l/min	



<b>Control type</b>	ON/OFF solenoid = LD8S
	proportional solenoid = LC8S
<b>Operation</b>	load-independent individual operation = E
	load-independent parallel operation = M
<b>Additional operator</b>	spool stroke limiter (only LD8S) = S
	manual override = N
	additional manual operator = W
<b>Attachment to flange face O</b>	port threads for line connections = *
	flange face for auxiliary valve = M
	without pressure compensator = O
	Compensator function: with flow limiter (SDR) = D
	with pressure compensator = I
	with pressure compensator and flow cut-off = L
	with pressure compensator, electroproportional flow cut-off = P
	with pressure compensator, electrically-ON/OFF flow cut-off = M
	with pressure compensator and 3-way pressure control = 1
	1 = up to 40 bar / 2 = up to 100 bar / 3 = up to 160 bar / 4 = up to 250 bar
<b>Type of connection at face O</b>	flange face to factory standard = ***
	line connection to port A and B: DIN 3852 - M18x1,5 = M18
	M22x1,5 = M22

<b>Nominal voltage</b>		<b>Connector socket</b>	
12 V DC = 12		AMP Junior Timer = J	
24 V DC = 24		Deutsch plug DT04-2P-EP04 = T	

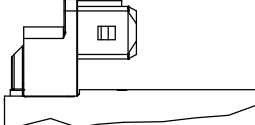
## 5.2.7 Connector socket

AMP Junior Timer J	DT04-2P-EP04 T
	

5.2.8 Dimensions

5.2.8.1 LD8S / LC8S core tube

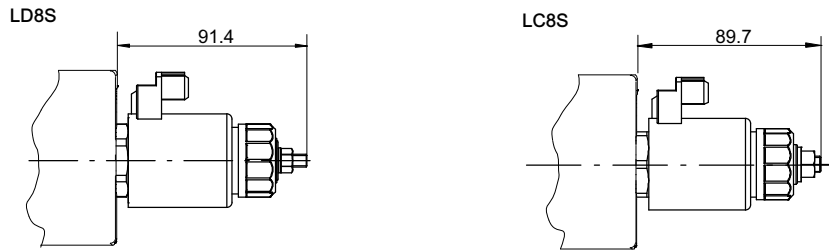

5.2.8.2 LD8S / LC8S-directional valve

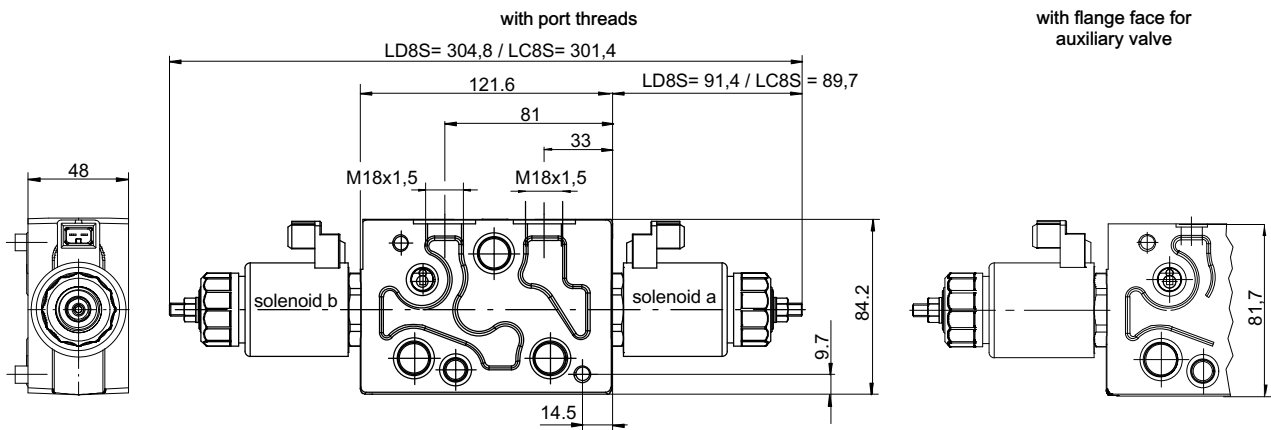

5.2.8.3 LD8SM / LC8SM-directional valve with integrated pressure compensator

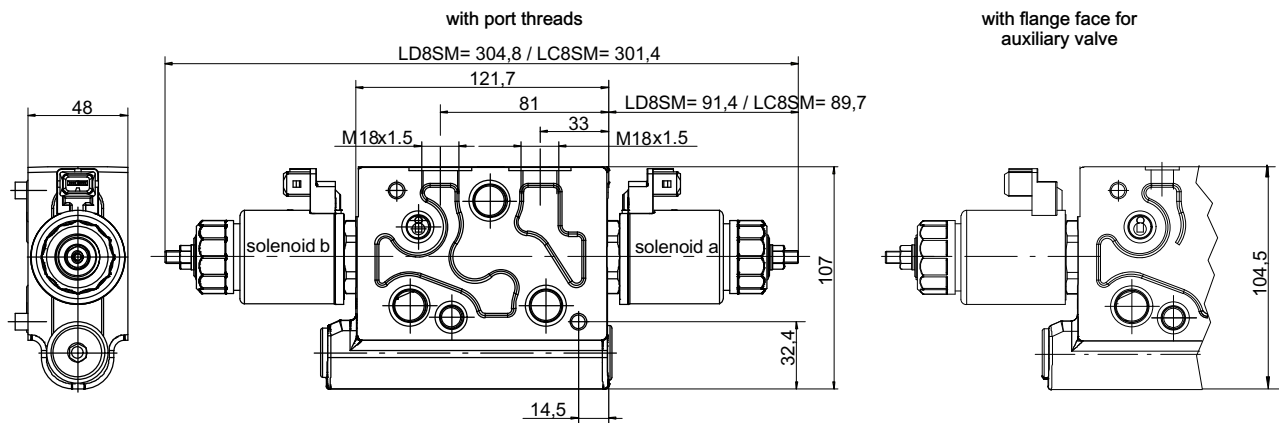

5.2.8.4 LD8S / LC8S-directional valve with integrated pressure compensator and flow cut-off

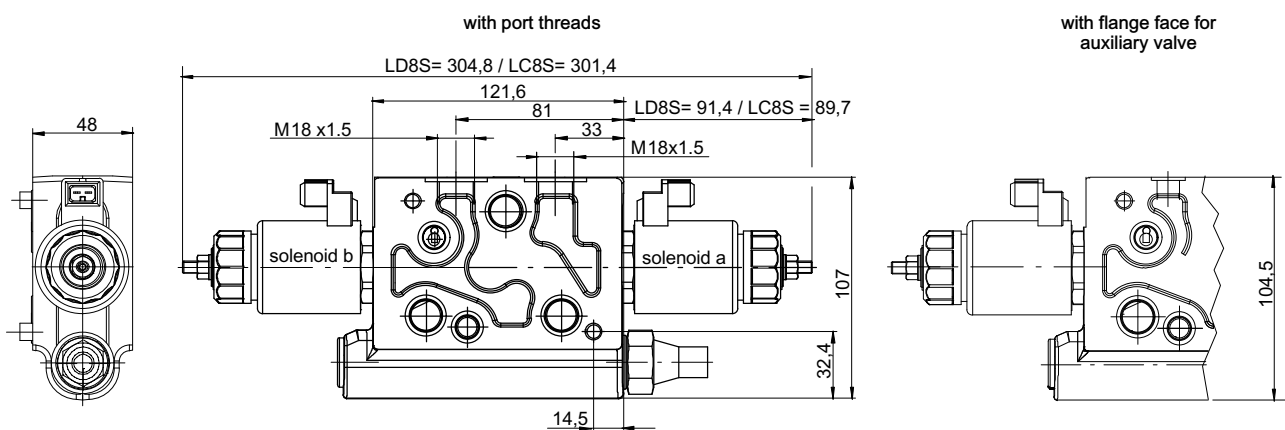

## 5.2.8.5 LD8S / LC8S-directional valve with manual override

with port threads  
LD8S = 381,2 / LC8S = 377,8

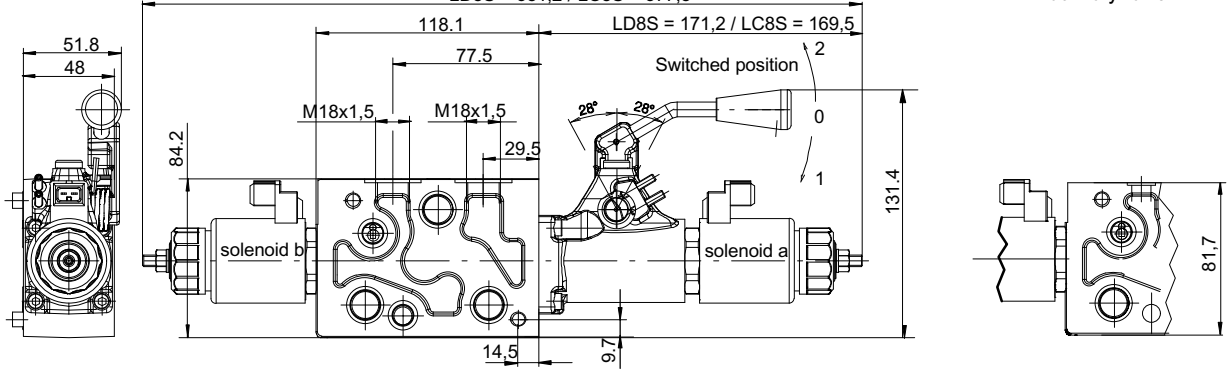

## 5.2.8.6 LD8S / LC8S-directional valve with manual override, pressure compensator and flow cut-off

with port threads  
LD8S = 381,2 / LC8S = 377,8

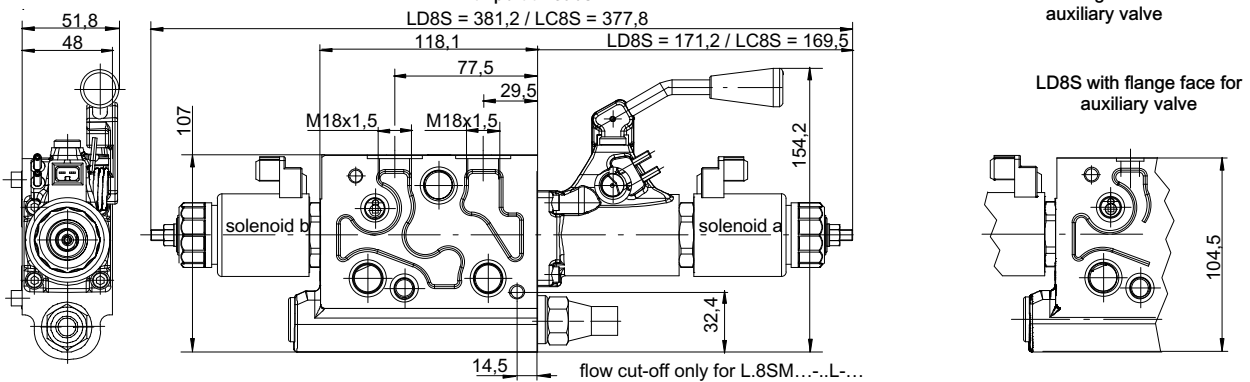

## 5.2.8.7 LD8S / LC8S-directional valve with pressure compensator, electrically-proportionally flow cut-off

with port threads  
LD8S = 359,6 / LC8S = 357,9

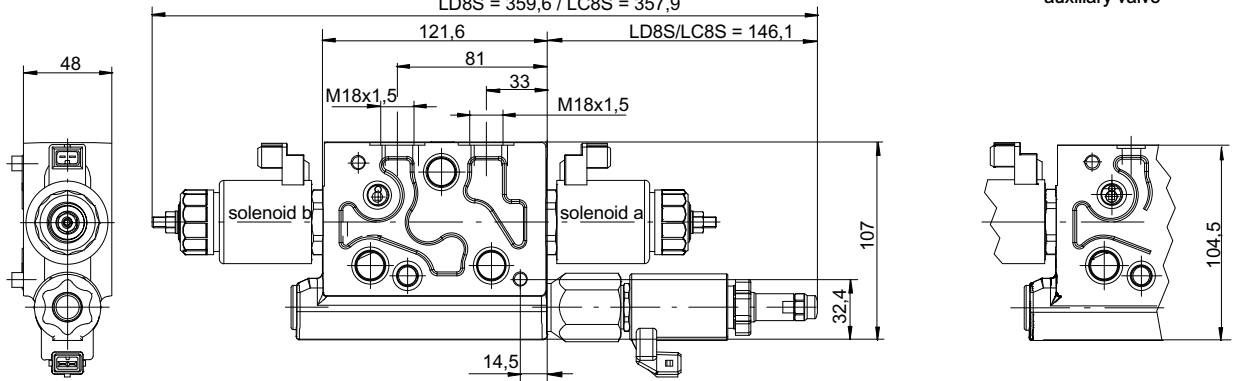

## 5.2.8.8 LD8S / LC8S-directional valve with pressure compensator and 3-way pressure control

with port threads  
LD8S = 326.7 / LC8S = 325

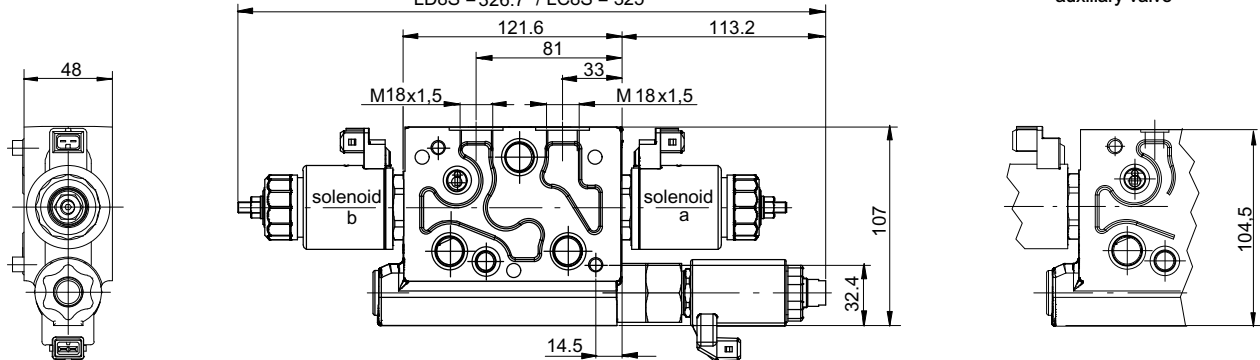

## 5.2.9 Ordering code

- White fields = data specified by Bucher Hydraulics
- Grey fields = fill out the fields according the option menu 5.2.6

L
D
8
S
E
3
A
1
0
\*
\*
-
S
\*
O
-
1
M
1
8
J
1
2
\*
 

ON/OFF solenoid = LD8S  
 Proportional solenoid = LC8S

Load-independent individual operation = E  
 Load-independent parallel operation = M

3-way function = 3  
 4-way function = 4

Spool function = A, D, E, F, I, J,

Port A spool code  
 02, 05, 10, 16, 25, 40, 60 = e.g. 10

Port B spool code: for 3-way function = \*\*  
 for 4-way function 02, 05, 10, 16, 25, 40, 60 = e.g. 10

Additional operator: without add. manual override (only for LC8S) = \*  
 with spool stroke limiter (only for LD8S) = S  
 with additional manual override = N  
 with manual override = W

Attachment to flange face O: port threads for line connection = \*  
 flange face for auxiliary valve = M

without pressure compensator = O  
 Compensator function: with flow limiter (SDR) = D  
 with integrated pressure compensator = I  
 with pressure compensator and flow cut-off = L  
 with pressure compensator, electrically-proportionally flow cut-off = P  
 with pressure compensator, electrically-ON/OFF flow cut-off = M  
 with pressure compensator, 3-way press. control (only up to 40 l/min) = e.g. 2  
 Information for pressure setting: 1=up to 40 bar / 2=up to 100 bar / 3=up to 160 bar / 4=up to 250 bar

Design stage (will be inserted by Bucher Hydraulics)

Type of connection at face O: flange face to factory standard = \*\*\*  
 line connection to port A and B: DIN 3852: M18 x 1,5 = M18  
 M22x1,5 = M22



Connector socket: AMP Junior Timer = J  
 Deutsch plug DT04-2P-EP04 = T

Nominal voltage: 12 V DC = 12  
 24 V DC = 24

Coating: without corrosion protection = \*  
 Zn/Ni coating = Z

Option: HPCO/Pressure Beyond for compatibility with 2/2 double-seat valve SVH04 (see chapter 10) = 02

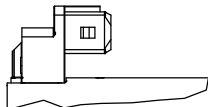
## 5.2.10 Connector socket

J = AMP Junior Timer	T = Deutsch plug DT04-2P-EP04
	

### 5.3 LM8S-/ LP8S- Directional valves

#### 5.3.1 Description

These directional valve sections, with two-stage solenoid/ hydraulic control, ON/OFF or proportional, are distinguished by their slim design and their adaptability. Auxiliary functions can be bolted on above or below the valve. To enable this, the appropriate interfaces must be chosen (see the following illustrations).

Manual overrides are available that act on the pilot stage, or directly on the main stage (non-following type). End-stops for the spool (special feature L.8S.../16) make it possible to limit the maximum actuator flow to any desired value.

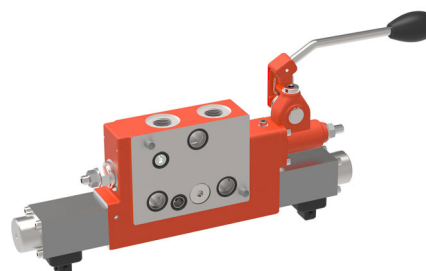

#### 5.3.2 Function

##### 5.3.2.1 LM8S with ON/OFF solenoid, two-stage

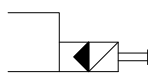

##### 5.3.2.2 LM8S with ON/OFF solenoid, two-stage optional manual override for the valve spool

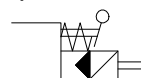

##### 5.3.2.3 LP8S with proportional solenoid, two-stage

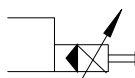

##### 5.3.2.4 LP8S with proportional solenoid, two-stage optional manual override for the valve spool

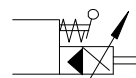

#### 5.3.3 Technical data

General characteristics	Unit	Description, value	
		LM8S	LP8S
Type of operation		ON/OFF	Proportional
Inlet pressure	bar	300	
Actuator pressure (10 sec/min)	bar	max. 315	
Spool size	l/min	10, 16, 25, 40, 63, 75 <sup>1)</sup>	
Solenoid design		ON/OFF solenoid with mechanical manual override	Proportional solenoid with mechanical manual override
Nominal voltage	V DC	12 V (10,8 ...14) 24 V (21,6 ...28)	12 or 24
Power consumption	Watt	24	12 or 24
Plug type		AMP Junior Timer, Deutsch plug DT04-2P-EP04	
Switch frequency	Hz	> 2 (please contact the factory)	
Duty cycle	%	100	100 with I <sub>max</sub> 1,6 A (U <sub>N</sub> 12 V) 0,8 A (U <sub>N</sub> 24 V)
Enclosure protection		AMP: IP65	DT04-2P: IP67 (DIN EN 60529)
Accessories		Joystick brochure 100-P-700071	

1) 75 l/min only available for spool types 4D and 3J. Higher flow rates on enquiry.

**IMPORTANT!**

If the maximum nominal voltage is exceeded, the solenoid can be damaged.

## 5.3.4 Performance graphs

### 5.3.4.1 Maximum flow rate at directional valve (without compensator), LS-function

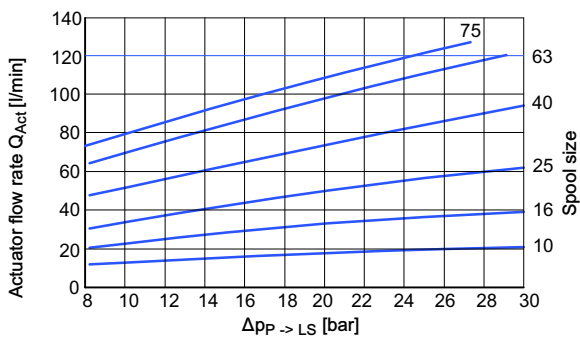

### 5.3.4.2 Pressure drop A/B → T (L.8S-directional valve)

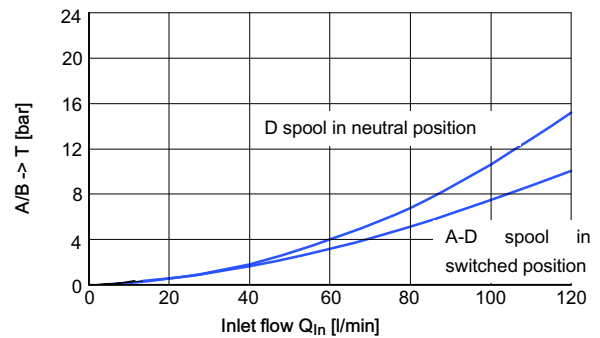

### 5.3.4.3 Pressure drop P → A/B (L.8S-directional valve), spool at max. switched position

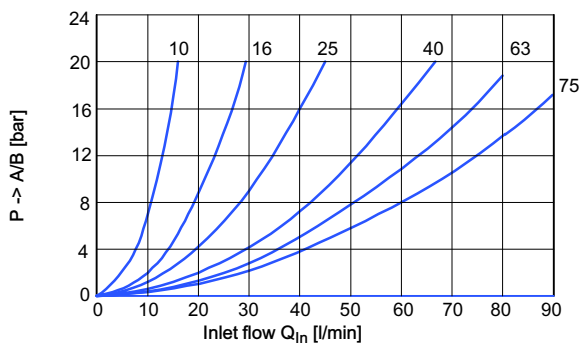

### 5.3.4.4 Control characteristic (LP8SM..) loop line (A→B / B→A)

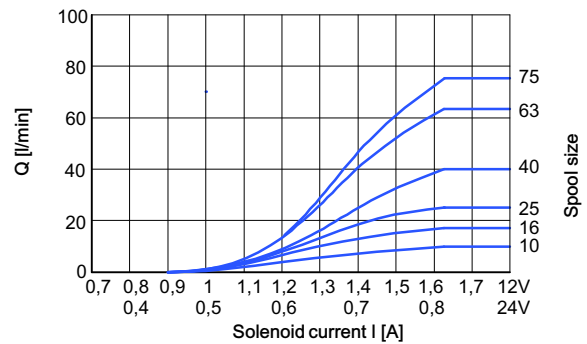

## 5.3.5 Overview of sections

### 5.3.5.1 LM8S / LP8S-directional valve with port threads

Symbol	Description	Part number
	L.8SE.....-**-..... • port threads for actuator A and B	see ordering code

### 5.3.5.2 LM8S / LP8S-directional valve for bolt-on auxiliary valve

Symbol	Description	Part number
	L.8SE.....-M*-..... • for bolt-on auxiliary valves on flange face O	see ordering code
	L.8SM.....-.*K-..... • for bolt-on auxiliary valves on flange face U	see ordering code
	L.8SM.....-MK-..... • for bolt-on auxiliary valves on flange faces O and U	see ordering code

## 5.3.6 Option menu for ordering code (ordering code see section 5.3.9)

**Spool type (way function, spool function, spool size in l/min)**

<p><b>3A</b></p> <p>10 l/min 16 l/min 25 l/min 40 l/min 63 l/min</p>	<p><b>4A</b></p> <p>05 05 l/min 10 10 l/min 16 16 l/min 25 25 l/min 40 40 l/min 63 63 l/min</p>	<p><b>4E</b></p> <p>10 10 l/min 40 40 l/min 63 63 l/min</p>
<p><b>3I</b></p> <p>10 l/min 16 l/min 25 l/min 40 l/min 63 l/min 75 l/min</p>	<p><b>4D</b></p> <p>05 05 l/min 10 10 l/min 16 16 l/min 25 25 l/min 40 40 l/min 63 63 l/min 75 75 l/min</p>	<p><b>4F</b></p> <p>16 16 l/min 40 40 l/min 63 63 l/min</p>

<b>Control types</b>	ON/OFF solenoid = LM8S proportional solenoid = LP8S
<b>Operation</b>	Load-independent individual operation = E load-independent parallel operation = M
<b>Additional operator</b>	without additional operator = * manual override (with lever) = N manual override (with rotary knob) (only operative in switch position 1) = S
<b>Attachment to flange face O</b>	port threads for line connection = * flange face for auxiliary valve = M
<b>Attachment to flange face U</b>	without (valve type E) = * with (valve type M) = K
<b>Type of connection at face O</b>	flange face to factory standard = *** line connection to port A and B: DIN 3852-M18 x 1.5 = M18 DIN 3852-M22 x 1.5 = M22
<b>Nominal voltage</b>	12 V DC = 12 24 V DC = 24
<b>Connector socket</b>	AMP Junior Timer = J Deutsch plug DT04-2P-EP04 = T

## 5.3.7 Connector socket

AMP Junior Timer J	Deutsch plug DT04-2P-EP04 T

5.3.8 Dimensions

5.3.8.1 LM8S-/ LP8S-directional valve with port threads

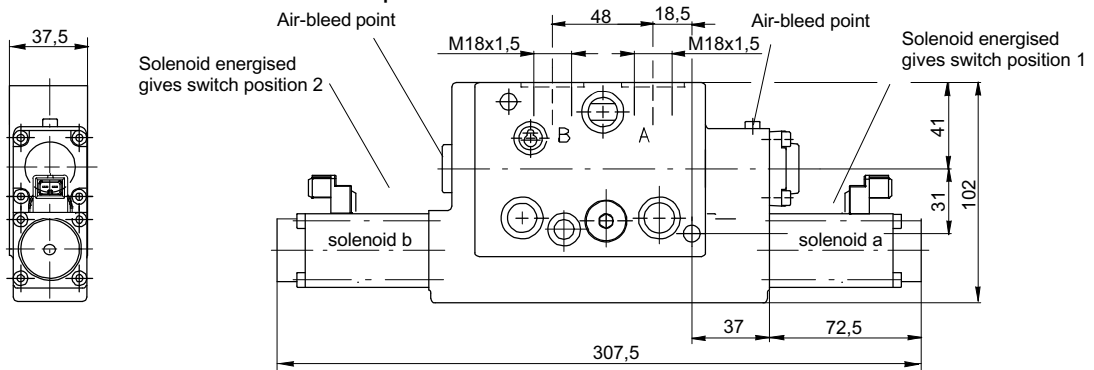

5.3.8.2 LM8S-/ LP8S-directional valve with facility for bolt-on auxiliary valves

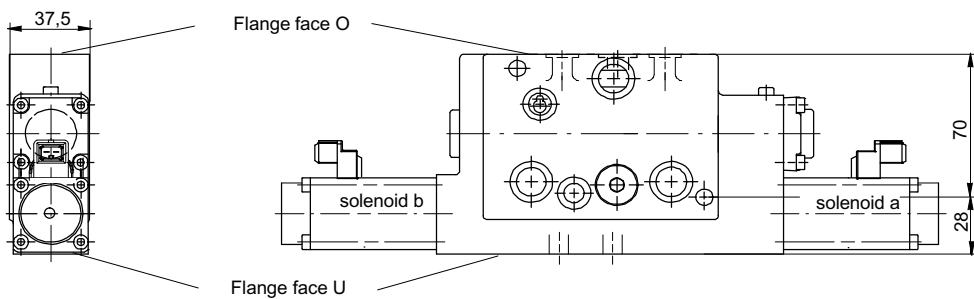

5.3.8.3 LM8S-/ LP8S-directional valve (spool types 3I and 3J)

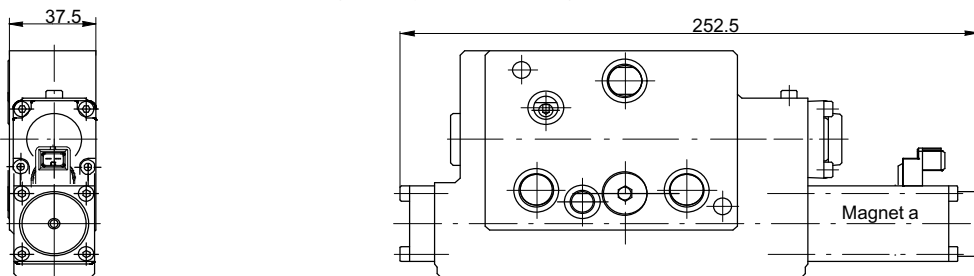

5.3.8.4 Manual override with rotary knob (L.8S.....S..)

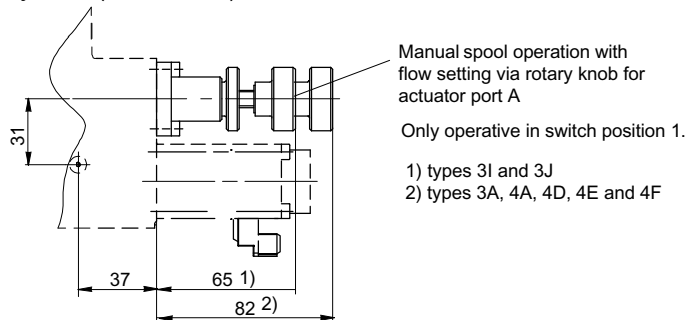

## 5.3.8.5 Manual override with lever (L.8S.....-N..)

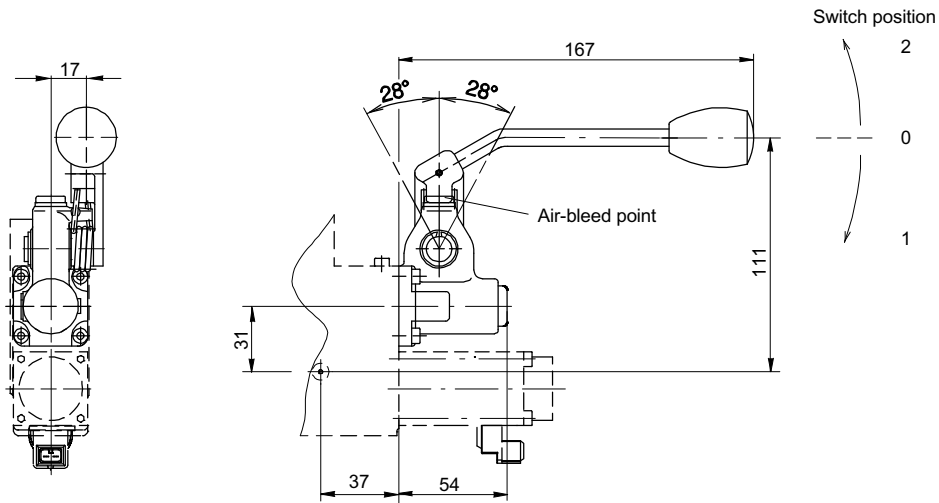

## 5.3.8.6 Spool stroke limiter (L.8S.../16)

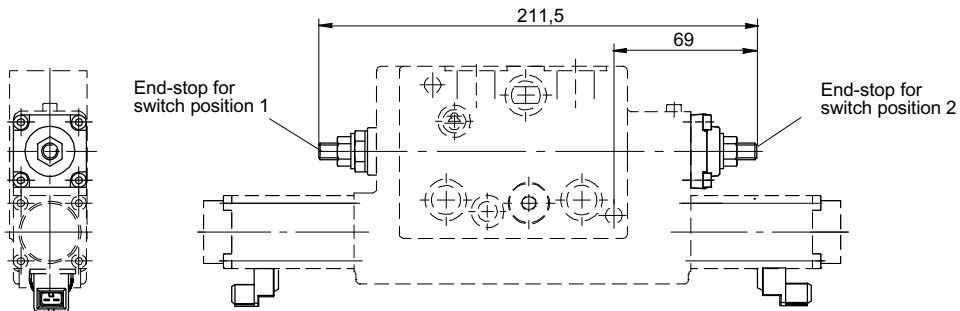

## 5.3.8.7 Manual override with lever and spool stroke limiter (L.8S.....-N.../16)

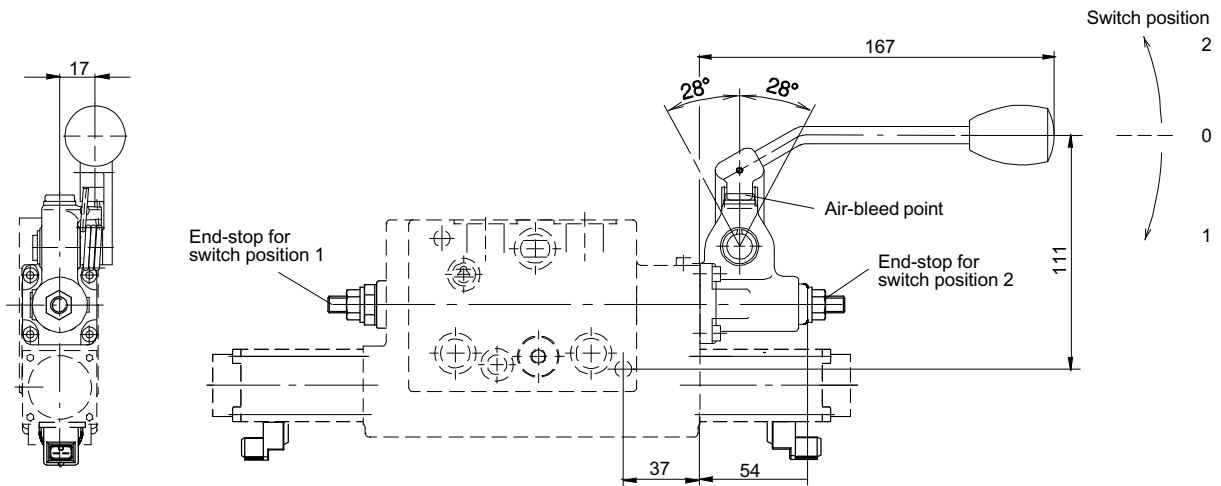



### 5.4 LH8S-Directional valves

#### 5.4.1 Description

These directional valve sections, operated by a hydraulic pilot stage, are distinguished by their slim design and their adaptability.

Auxiliary functions can be bolted on above or below the valve. To enable this, the appropriate interfaces must be chosen (see the following illustrations).

Various manual overrides and end-stops for the spool make it possible to limit the maximum actuator flow to any desired value.

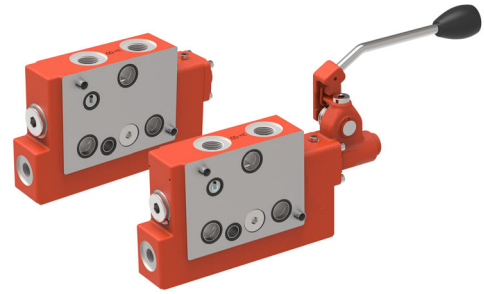

#### 5.4.2 Function

##### 5.4.2.1 LH8S hydraulic operation

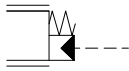

##### 5.4.2.2 LH8S optional manual override for the valve spool

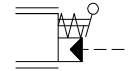

#### 5.4.3 Technical data

General characteristics	Unit	Description, value
Inlet pressure	bar	max. 300
Actuator pressure (duty cycle 10 sec/min)	bar	max. 315
Spool size	l/min	10, 16, 25, 40, 63, 75 <sup>1)</sup>
Pilot pressure	bar	max. 50
Pilot pressure over tank pressure	bar	4 ... 16 (other pilot pressures on enquiry)

1) 75 l/min only available for 4D and 3J spool types. Higher flow rates on enquiry.

#### 5.4.4 Performance graphs

##### 5.4.4.1 Maximum flow rate at directional valve (without compensator), LS-function

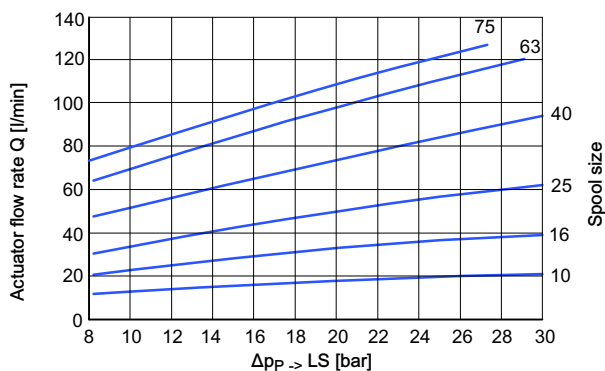

##### 5.4.4.2 Pressure drop A/B -> T (L.8S-directional valve)

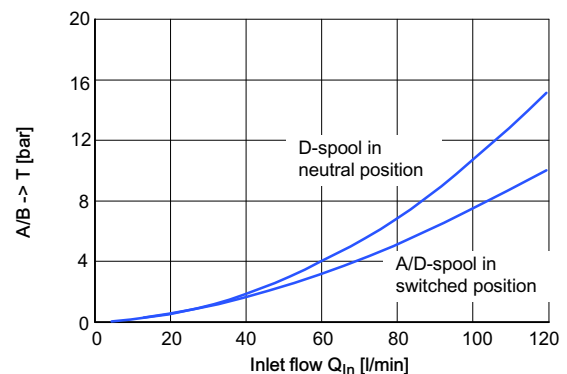

### 5.4.4.3 Pressure drop P → A/B (L.8S-directional valve) spool at max. switched position

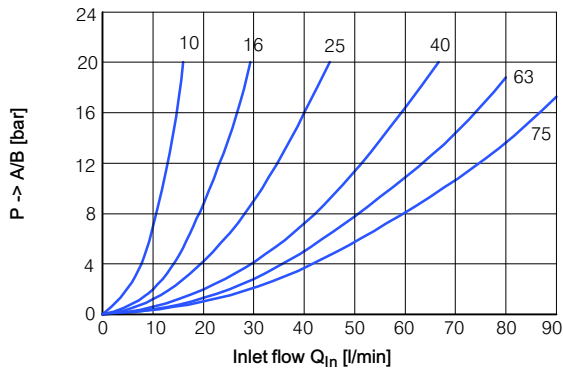

### 5.4.4.4 Control characteristic

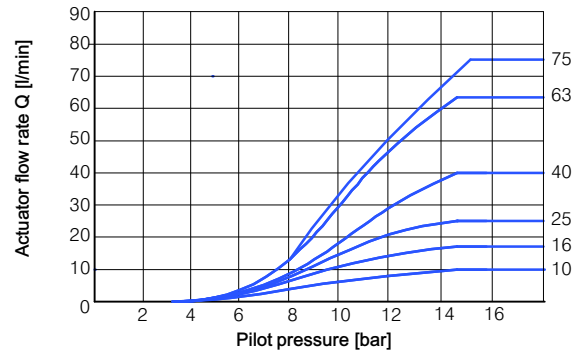

## 5.4.5 Overview of sections

### 5.4.5.1 LH8SE-directional valve with port threads

Symbol	Description	Part number
	<b>LH8SE.....-.*-....</b> <ul style="list-style-type: none"> <li>port threads for actuator A and B</li> </ul>	see ordering code

### 5.4.5.2 LH8SM-directional valves for bolt-on auxiliary valve

Symbol	Description	Part number
	<b>LH8SM.....-.*K-....</b> <ul style="list-style-type: none"> <li>for bolt-on auxiliary valves on flange face U</li> </ul>	see ordering code
	<b>LH8SE.....-.*-....</b> <ul style="list-style-type: none"> <li>for bolt-on auxiliary valves on flange face O</li> </ul>	see ordering code
	<b>LH8SM.....-.*MK-....</b> <ul style="list-style-type: none"> <li>for bolt-on auxiliary valves on flange faces O and U</li> </ul>	see ordering code



5.4.7.2 LH8S-directional valves (with flange face to bolt-on auxiliary valves)

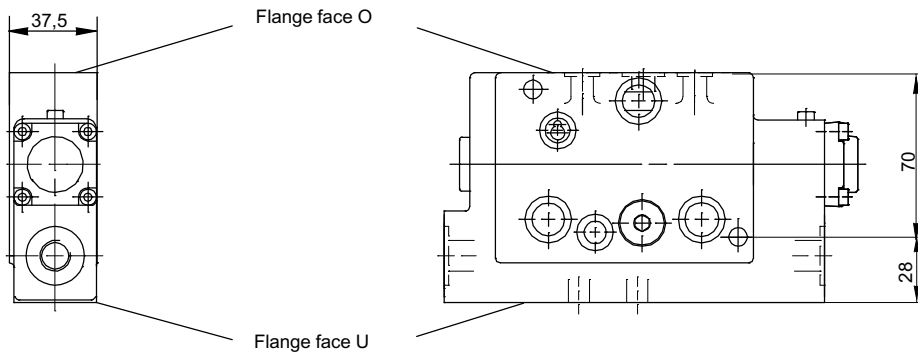

5.4.7.3 Manual override for LH8S-directional valves (LH8S.....-N..)

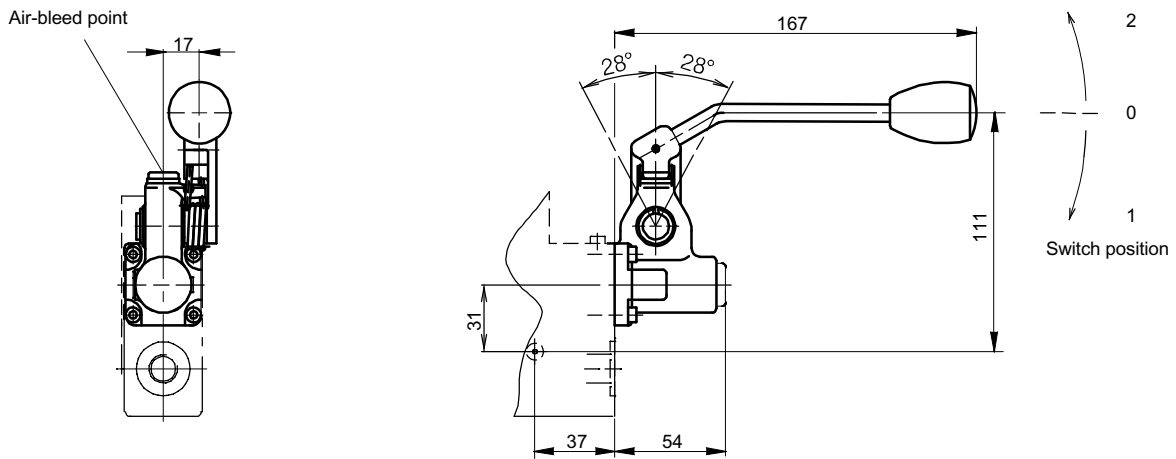

5.4.7.4 Manual override for LH8S-directional valves and spool stroke limiter (LH8S.....-N../16)

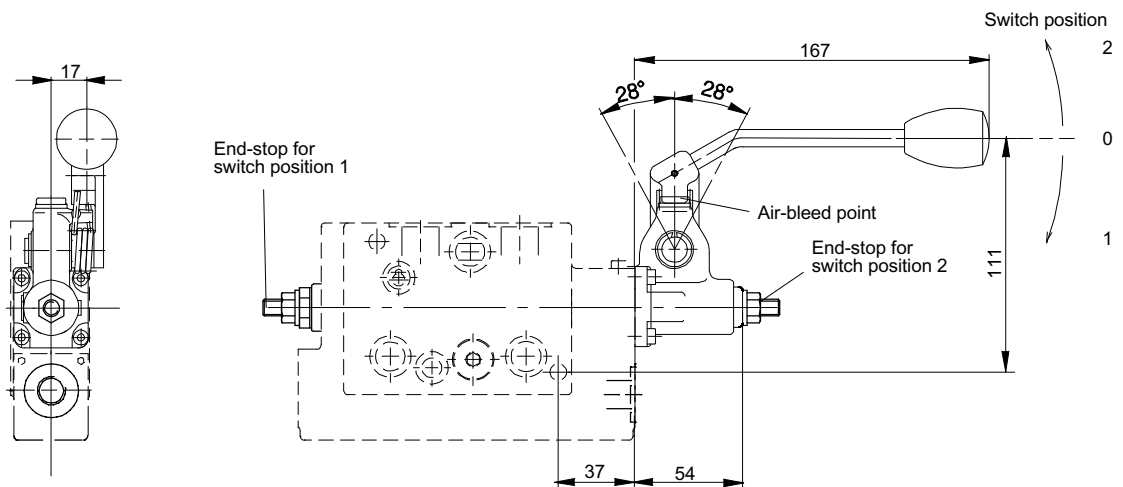

### 5.4.8 Ordering code

- White fields = data specified by Bucher Hydraulics
- Grey fields = fill out the fields according the option menu 5.4.6

L H 8 S | 
 M 4 | 
 D 2 5 2 5 - 
 \* \* | 
 K - 
 1 | 
 M 1 8 \*  

Hydraulic operation = LH8S

Load-independent individual operation = E  
 Load-independent parallel operation = M

3-way function = 3  
 4-way function = 4

Spool function  
 A, D, E, F, I, J = e.g. D

Port A spool code  
 10, 16, 25, 40, 63, 75 <sup>1)</sup> = e.g. 25

Port B spool code  
 for 3-way function = \*\*  
 for 4-way function 10, 16, 25, 40, 63, 75 <sup>1)</sup> = e.g. 25

Additional operator  
 without = \*  
 manual override (with lever) = N

Attachment to flange face O  
 port threads for line connection = \*  
 flange face for auxiliary valve = M

Attachment to flange face U  
 without flange face U (for load-independent individual operation) = \*  
 with flange face U (for load-independent parallel operation) = K

Design stage (to be inserted by Bucher Hydraulics)

Type of connection at face O  
 flange face to factory standard = \*\*\*  
 line connection to ports A and B:  
     DIN 3852 - M18 x 1,5 = M18  
     DIN 3852 - M22 x 1,5 = M22 <sup>2)</sup>

Option  
     Spool stroke limiting at A and B = 16  
     No check valve in P (from 63 l/min) = 22 <sup>2)</sup>

1) 75 l/min only for spool function 4D and 3J). Higher flow rates on enquiry.  
 2) P reduces to 250 bar.

## 6 Auxiliary valves that bolt-on to the top flange face O

### 6.1 Anti-shock / make-up valves (secondary pressure relief)

#### 6.1.1 Description

These bolt-on anti-shock/make-up valves are mounted on flange face O. They protect the actuator from unacceptably-high pressure peaks.

The excess pressure is discharged to tank. The integral make-up function protects against cavitation. The following combinations are available in the pressure ranges listed.

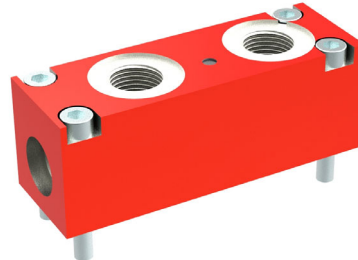

#### 6.1.2 Technical data

General characteristics	Unit	Description, value
Pressure settings available (measured at 4 l/min test flow)	bar	80, 100, 125, 140, 160, 175, 190, 210, 230, 250, 280, 300
Nominal flow rate Q <sub>max</sub>	l/min	60
Pressure drop through make-up valve	bar	4 at 30 l/min
Port threads to DIN 3852		M18 x 1,5

#### 6.1.3 Overview of sections

Symbol	Description	Part number
<p>Directional valve</p>	<p><b>LU8SPET-NVONVO-1M18*00</b></p> <ul style="list-style-type: none"> <li>actuator port A and B: without pressure relief, with make-up valve</li> </ul>	<b>100015777</b>
<p>Directional valve</p>	<p><b>LU8SPET-080080-0M18*00</b></p> <ul style="list-style-type: none"> <li>actuator port A and B: with pressure relief with make-up valve</li> </ul>	<b>100015727</b> p = 80 bar
<p>Directional valve</p>	<p><b>LU8SPET-100100-0M18*00</b></p> <ul style="list-style-type: none"> <li>actuator port A and: with pressure relief with make-up valve</li> </ul>	<b>100015655</b> p = 100 bar
<p>Directional valve</p>	<p><b>LU8SPET-125125-0M18*00</b></p> <ul style="list-style-type: none"> <li>actuator port A and B: with pressure relief with make-up valve</li> </ul>	<b>100015664</b> p = 125 bar
<p>Directional valve</p>	<p><b>LU8SPET-140140-0M18*00</b></p> <ul style="list-style-type: none"> <li>actuator port A and B: with pressure relief with make-up valve</li> </ul>	<b>100015280</b> p = 140 bar
<p>Directional valve</p>	<p><b>LU8SPET-160160-0M18*00</b></p> <ul style="list-style-type: none"> <li>actuator port A and B: with pressure relief with make-up valve</li> </ul>	<b>100015656</b> p = 160 bar

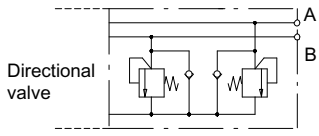
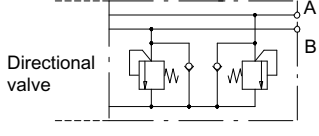
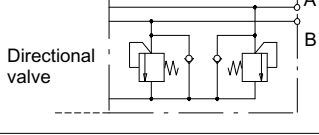
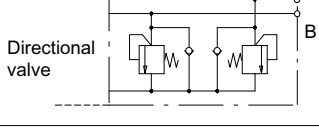
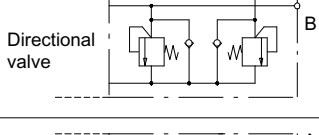
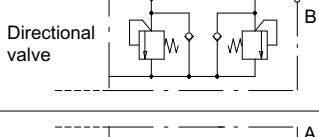
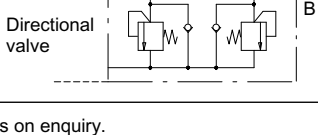
 <p>Directional valve</p>	<b>LU8SPET-175175-0M18*00</b>	<b>100018657</b>
<ul style="list-style-type: none"> <li>actuator port A and B: with pressure relief with make-up valve</li> </ul>	$p = 175 \text{ bar}$	
 <p>Directional valve</p>	<b>LU8SPET-190190-0M18*00</b>	<b>100015665</b>
<ul style="list-style-type: none"> <li>actuator port A and B: with pressure relief with make-up valve</li> </ul>	$p = 190 \text{ bar}$	
 <p>Directional valve</p>	<b>LU8SPET-210210-0M18*00</b>	<b>100015615</b>
<ul style="list-style-type: none"> <li>actuator port A and B: with pressure relief with make-up valve</li> </ul>	$p = 210 \text{ bar}$	
 <p>Directional valve</p>	<b>LU8SPET-230230-0M18*00</b>	<b>100015666</b>
<ul style="list-style-type: none"> <li>actuator port A and B: with pressure relief with make-up valve</li> </ul>	$p = 230 \text{ bar}$	
 <p>Directional valve</p>	<b>LU8SPET-250250-0M18*00</b>	<b>100015657</b>
<ul style="list-style-type: none"> <li>actuator port A and B: with pressure relief with make-up valve</li> </ul>	$p = 250 \text{ bar}$	
 <p>Directional valve</p>	<b>LU8SPET-280280-0M18*00</b>	<b>100015658</b>
<ul style="list-style-type: none"> <li>actuator port A and B: with pressure relief with make-up valve</li> </ul>	$p = 280 \text{ bar}$	
 <p>Directional valve</p>	<b>LU8SPET-300300-0M18*00</b>	<b>100021038</b>
<ul style="list-style-type: none"> <li>actuator port A and B: with pressure relief with make-up valve</li> </ul>	$p = 300 \text{ bar}$	

Others on enquiry.

## 6.1.4 Dimensions

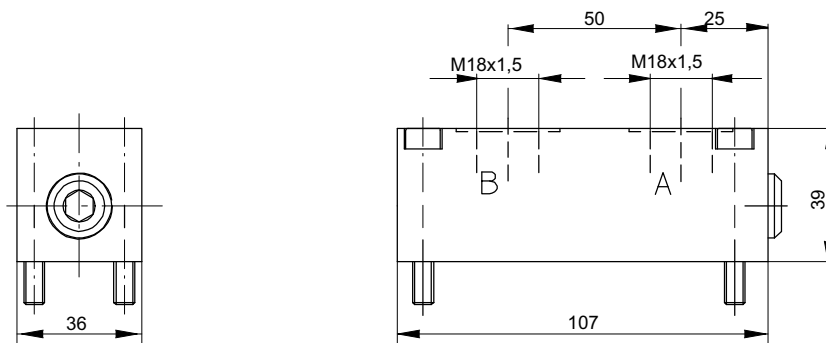

## 6.2 Check valves (pilot operated non return valves)

### 6.2.1 Description

These bolt-on load check valves with hydraulic or solenoid operation shut off the actuator lines with zero leakage.

The valves must be mounted on flange face O of the directional valve. The following variants are available.

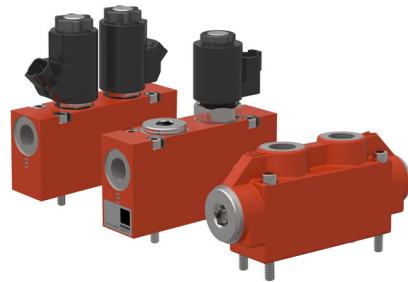

### 6.2.2 Technical data

General characteristics	Unit	Description, value		
		LU8SPRH...	LU8SPR1-...	LU8SPR2-...
Function		Hydraulic operated	Solenoid operated	Electrohydraulic operated
Nominal flow rate	l/min	63	30	70
Operating pressure	bar	max. 250	max. 210	max. 280
Actuator pressure	bar	max. 280	max. 250	max. 300
Port thread		DIN 3852 - M18 x 1,5		
Ratio of opening pressure to opposing pressure for double-acting cylinders		1 : 6,25 <sup>1)</sup>		
Pressure drop	bar	7 at 63 l/min	10 at 30 l/min	10 at 63 l/min
Nominal voltage	V DC		12 or 24	
Power consumption	Watt		27	22
Duty cycle	%		100	
Enclosure protection			AMP Junior Timer: IP65 Deutsch plug DT04: IP67 (DIN EN 60529)	
Connector socket			Deutsch plug DT04-2P-EP04, AMP Junior Timer	

1) Others on enquiry.

### 6.2.3 Overview of sections

#### 6.2.3.1 LU8SPRH-... (hydraulic operated, $Q_{max} = 63$ l/min)

Symbol	Description	Part number
<p>Directional valve</p>	<b>LU8SPRH-DVADVB-0M18*00</b> <ul style="list-style-type: none"> <li>actuator port A: with check valve</li> <li>actuator port B: with check valve</li> </ul>	100015612
<p>Directional valve</p>	<b>LU8SPRH-DVA***-0M18*00</b> <ul style="list-style-type: none"> <li>actuator port A: with check valve</li> <li>actuator port B: without valve</li> </ul>	100015613
<p>Directional valve</p>	<b>LU8SPRH-***DVB-0M18*00</b> <ul style="list-style-type: none"> <li>actuator port A: without valve</li> <li>actuator port B: with check valve</li> </ul>	100015614

Others on enquiry.

### 6.2.3.2 LU8SPR1-... (solenoid operation, $Q_{max}$ 30 l/min)

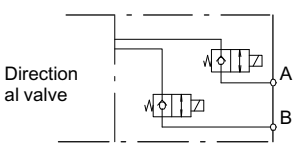
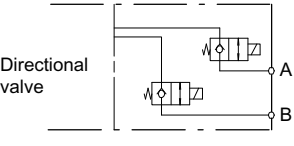
Symbol	Description	Part number
 <p>Directional valve</p>	<b>LU8SPR1-DVADVB-0M18T12*00</b> <ul style="list-style-type: none"> <li>actuator port A and B: with check valve</li> <li>connector socket DT04-2P-EP04</li> <li>nominal voltage 12 V DC</li> </ul>	<b>100035157</b>
 <p>Directional valve</p>	<b>LU8SPR1-DVADVB-0M18T24*00</b> <ul style="list-style-type: none"> <li>actuator port A and B: with check valve</li> <li>connector socket DT04-2P-EP04</li> <li>nominal voltage 24 V DC</li> </ul>	<b>100024626</b>

Others on enquiry.

### 6.2.3.3 LU8SPR2-... (solenoid operation, $Q_{max}$ 70 l/min)

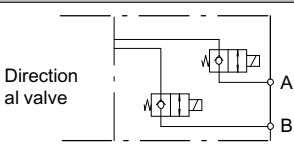
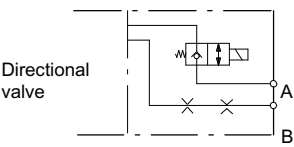
Symbol	Description	Part number
 <p>Directional valve</p>	<b>LU8SPR2-DVADVB-2M18T24*00</b> <ul style="list-style-type: none"> <li>actuator port A and B: with check valve</li> <li>connector socket DT04-2P-EP04</li> <li>nominal voltage 24 V DC</li> </ul>	<b>100040171</b>
 <p>Directional valve</p>	<b>LU8SPR2-DVA***-2M18T24*00</b> <ul style="list-style-type: none"> <li>actuator port A: with check valve</li> <li>actuator port B: without valve</li> <li>connector socket DT04-2P-EP04</li> <li>nominal voltage 24 V DC</li> </ul>	<b>100040168</b>

Others on enquiry.

### 6.2.4 Connector socket

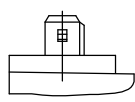
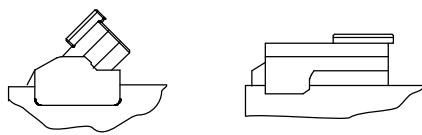
AMP Junior Timer J	Deutsch plug DT04-2P-EP04 T
	

6.2.5 Dimensions

6.2.5.1 LU8SPRH-...

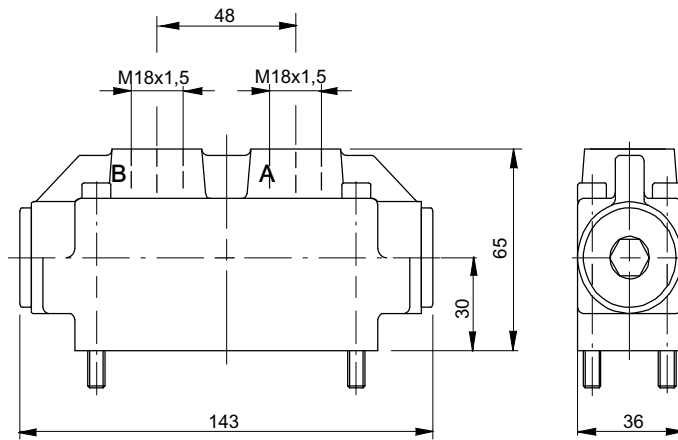

6.2.5.2 LU8SPR1-...

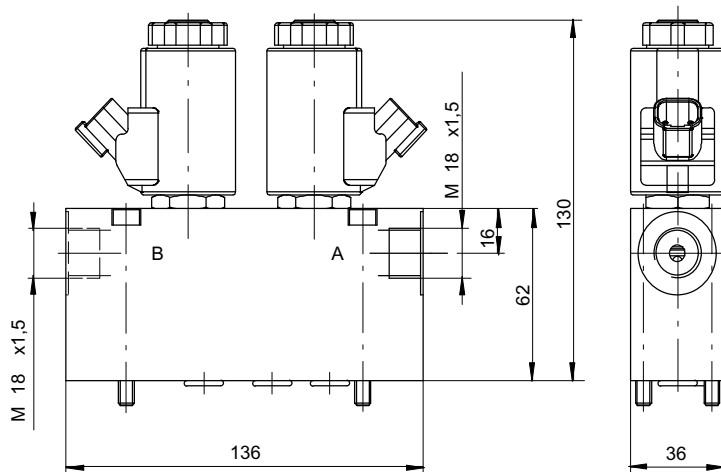

6.2.5.3 LU8SPR2-...

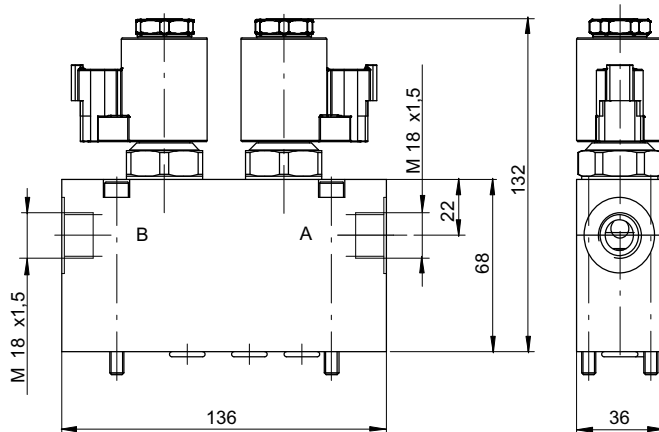

### 6.3 Load check valves with anti-shock / make-up valves (pilot operated non-return valve with pressure relief on the actuator side)

#### 6.3.1 Description

These bolt-on load check valves with service line anti-shock/make-up valves shut off the actuator lines with zero leakage and protect the actuator from unacceptably-high pressure peaks.

The valves must be mounted on flange face O of the directional valve. The relevant pressure settings are detailed below.

Not usable for LA8S.. valves and LM8S../LP8S.. valves with emergency override.

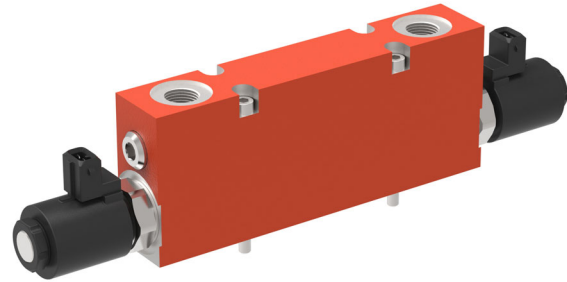

#### 6.3.2 Technical data

General characteristics	Unit	Description, value
Nominal flow rate	l/min	70
Operating pressure	bar	max. 280
Actuator pressure	bar	max. 300
Pressure drop	bar	10 at 63 l/min
Pressure settings available for the pressure relief function (measured at 10l/min test flow)	bar	80, 100, 125, 140, 160, 175, 190, 210, 230, 250, 280, 300
Port threads		M18 x 1,5 to DIN 3852
Nominal voltage	V DC	12 or 24
Connector socket		DT04-2P-EP04, AMP Junior Timer
Power consumption	Watt	22
Duty cycle	%	100
Enclosure protection	%	AMP: IP65      DT: IP67 (DIN EN 60529)

#### 6.3.3 Overview of sections

##### 6.3.3.1 LU8SPEC-...

Symbol	Description	Part number
	<b>LU8SPEC-300300-2M18J24*00</b>	<b>100040154</b>
	<ul style="list-style-type: none"> <li>actuator port A and B: check valve p = 300 bar flow cut-off</li> <li>connector socket: AMP Junior Timer / nominal voltage 24 V DC</li> </ul>	
	<b>LU8SPEC-250250-2M18J24*15</b>	<b>100040156</b>
	<ul style="list-style-type: none"> <li>actuator port A and B: check valve p = 250 bar flow cut-off</li> <li>connector socket: AMP Junior Timer / nominal voltage 24 V DC</li> </ul>	

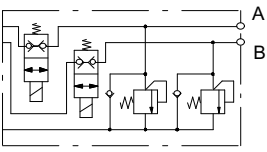
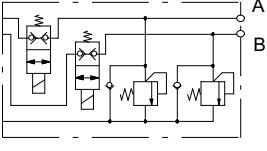
	<b>LU8SPEC-280280-2M18J24*15</b>	<b>100040325</b>
<ul style="list-style-type: none"> <li>actuator port A and B: check valve p = 280 bar flow cut-off</li> <li>connector socket: AMP Junior Timer / nominal voltage 24 V DC</li> </ul>		
	<b>LU8SPEC-250250-2M18J12*15</b>	<b>100040913</b>
<ul style="list-style-type: none"> <li>actuator port A and B: check valve p = 250 bar flow cut-off</li> <li>connector socket: AMP Junior Timer / nominal voltage 12 V DC</li> </ul>		

Others on request.

### 6.3.4 Connector socket

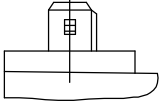
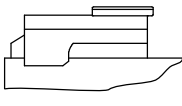
<b>AMP Junior Timer J</b>	<b>DT04-2P-EP04 T</b>
	

### 6.3.5 Dimensions

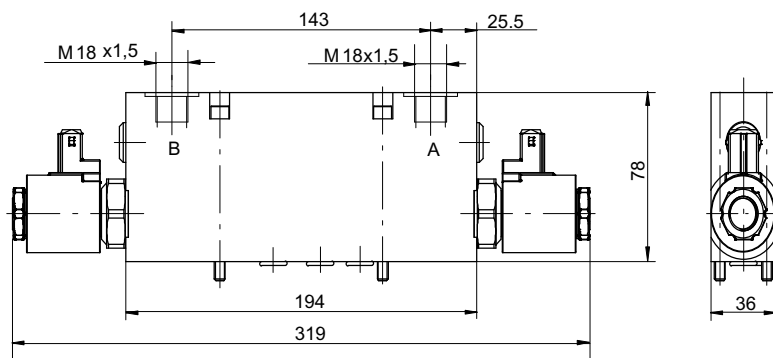

## 6.4 Load control valves

### 6.4.1 Description

These bolt-on load control valves with integral anti-shock function ensure load-independent lowering motion at speeds determined by the inlet flow. The load-control valves close without leakage when the directional valve is in its neutral position. The anti-shock valve setting should preferably be 120% of the highest load pressure. Turning the adjusting screw in the clockwise direction reduces the setting, and this can also be used for emergency lowering of the load.

The valves must be mounted on flange face O.  
The following variants are available.

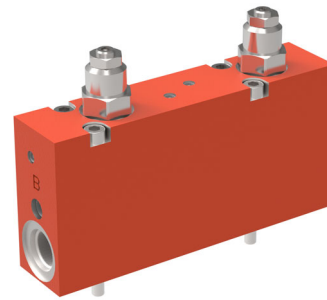

### 6.4.2 Function

#### 6.4.2.1 LU8SPBH-\*\*\*S. . .-...

Load-holding valve at port B, orifice damping facility in the control line. Directional valve spool type 4F preferred.

#### 6.4.2.2 LU8SPBH-S. . S. .-...

Load-holding valves at port A and B. Directional valve spool type 4D preferred.

### 6.4.3 Technical data

General characteristics	Unit	Description, value
Port threads to DIN3852		M18 x 1,5
Pressure drop	bar	25 at 63 l/min
Anti-shock valve adjustable	bar	70 ... 280
Standard pilot ratios	bar	1,5:1 / 2,3:1 / 3:1 <sup>1)</sup>

1) For other pilot ratios, please enquire.

### 6.4.4 Overview of sections

Symbol	Description	Part number
	<b>LU8SPBH-S15S15-0M18*00/PA=PB=</b> • actuator port A and B: with load control, pilot ratio 1,5:1 ⇒ Specify the pressure relief setting in bar	see order details chapter 1.1
	<b>LU8SPBH-***S15-0M18*00/PB=</b> • actuator port A: without load-control • actuator port B: with load-control, pilot-ratio 1,5 : 1 ⇒ Specify the pressure relief setting in bar	see order details chapter 1.1
	<b>LU8SPBH-E30E30-0M18*00/PA=PB=</b> • actuator port A and B: with load-control, pilot-ratio 3:1 ⇒ Specify the pressure relief setting in bar	see order details chapter 1.1
	<b>LU8SPBH-***E30-0M18*00/PB=</b> • actuator port A: without load-control • actuator port B: with load-control, pilot-ratio 3:1 ⇒ Specify the pressure relief setting in bar	see order details chapter 1.1

Others on enquiry.

## 6.4.5 Dimensions

### 6.4.5.1 LU8SSPBH-\*\*\*S.. / LU8SSPBH-...S..

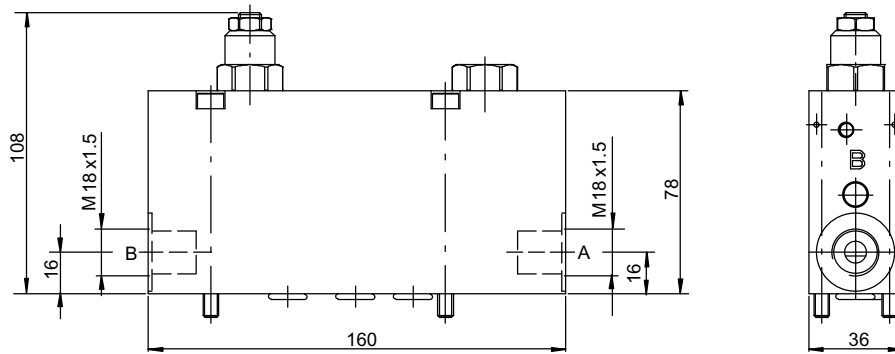

### 6.4.5.2 LU8SSPBH-S..S..

Cannot be combined with manual override on LC8S / LD8S / LM8S / LP8S / LH8S; LA8S only when the lever pointing down.

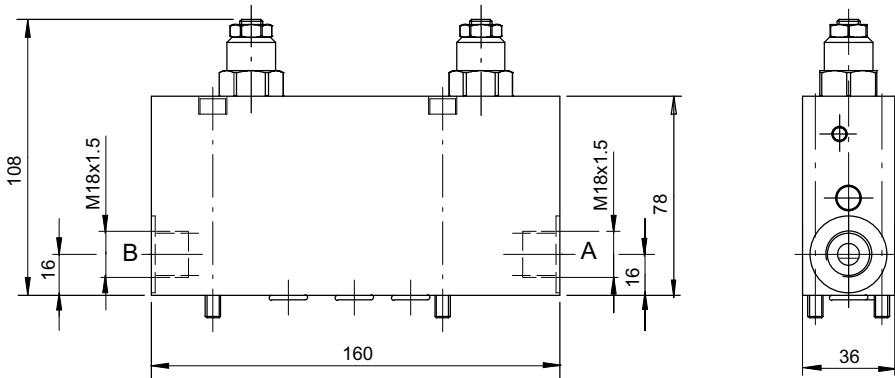

### 7 Auxiliary valves that bolt-on to the bottom flange face U

#### 7.1 Individual pressure compensator without / with flow cut-off (torque-limiting)

##### 7.1.1 Description

The individual pressure compensators (2-way compensators), which bolt-on to the bottom of the directional valve, keep the  $\Delta p$  over the spool opening at a constant level, even with high inlet pressures. This means that the actuator flow remains constant and load-independent even if another actuator that needs a higher pressure is operated at the same time. There is an optional flow cut-off function at an adjustable pressure, above which level the actuator flow goes to zero. The valves must be mounted on flange face U of the directional valve.

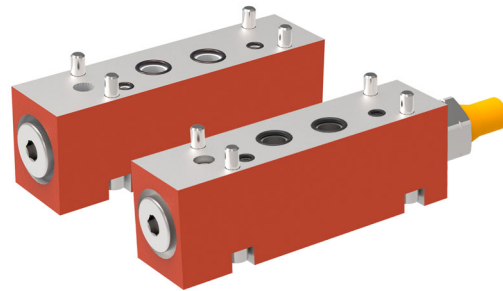

##### 7.1.2 Technical data

General characteristics	Unit	Description, value
Operating pressure	bar	max. 300
Pressure for flow cut-off	bar	adjustable, 50 ... 300
Nominal flow rate SKL / SKM SKJ / SKH	l/min	max. 63 max. 75

##### 7.1.3 Performance graphs

###### 7.1.3.1 Maximum flow rate at directional valve when using the LU8SSKL / SKM compensator in conjunction with an LU8SSCS inlet section

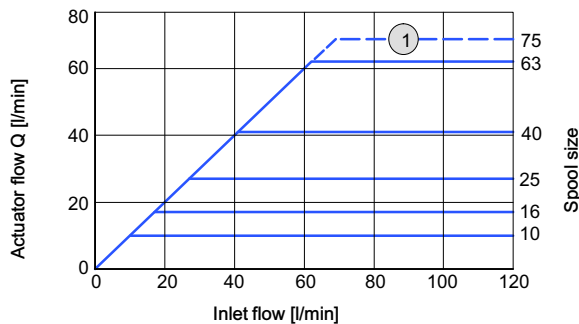

###### 7.1.3.2 Flow cut-off function of an LU8SSKM / SKJ bottom-mounting plate

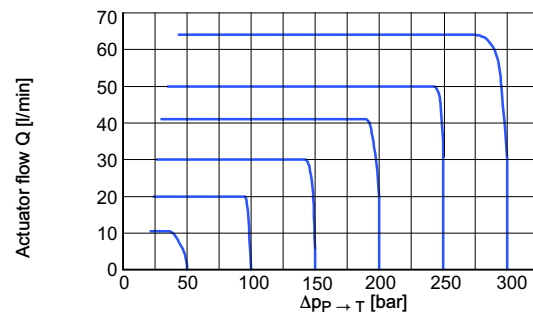

1 Maximum flow rate at directional valve when using the LU8SSKH / SKJ compensator in conjunction with an LU8SSCS inlet section

## 7.1.4 Overview of sections

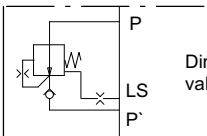
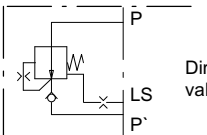
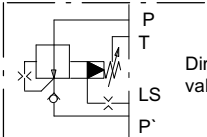
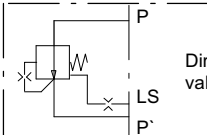
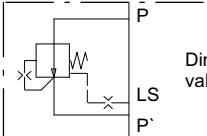
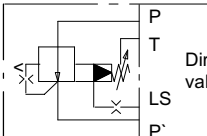
Symbol	Description	Part number
	<b>LU8SSKL-0*00</b>	<b>100015779</b>
	<ul style="list-style-type: none"> <li>• without flow cut-off</li> <li>• with no-drop function</li> <li>• nominal flow rate maximum. 63 l/min</li> </ul>	
	<b>LU8SSKL-0*01</b>	<b>100013943</b>
	<ul style="list-style-type: none"> <li>• without flow cut-off</li> <li>• with no-drop function</li> <li>• damped model</li> <li>• nominal flow rate maximum 63 l/min</li> </ul>	
	<b>LU8SSKM-0*00/P=</b>	see order details chapter 1.1
	<ul style="list-style-type: none"> <li>• with flow cut-off</li> <li>• with no-drop function</li> <li>• nominal flow rate maximum 63 l/min</li> </ul> ⇒ specify the pressure relief setting in bar	
	<b>LU8SSKH-0*00</b>	<b>100025901</b>
	<ul style="list-style-type: none"> <li>• without flow cut-off</li> <li>• without no-drop function</li> <li>• nominal flow rate maximum 75 l/min</li> </ul>	
	<b>LU8SSKH-0*01</b>	<b>100027017</b>
	<ul style="list-style-type: none"> <li>• without flow cut-off</li> <li>• without no-drop function</li> <li>• damped model</li> <li>• nominal flow rate maximum 75 l/min</li> </ul>	
	<b>LU8SSKJ-0*00/P=</b>	see order details chapter 1.1
	<ul style="list-style-type: none"> <li>• with flow cut-off</li> <li>• without no-drop function</li> <li>• nominal flow rate maximum 75 l/min</li> </ul> ⇒ specify the pressure relief setting in bar	

Others on enquiry.

## 7.1.5 Dimensions

### 7.1.5.1 LU8SSKL / LU8SSKM

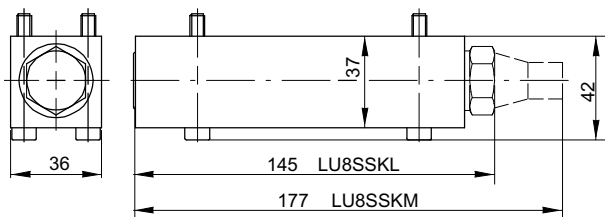

### 7.1.5.2 LU8SSKH / LU8SSKJ

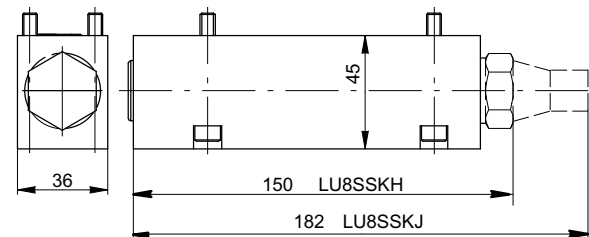

### 7.2 Flow limiter without / with individual pressure compensators

#### 7.2.1 Description

This flow limiters, which bolt-on to the bottom of the directional valve, are another metering orifice in addition to the one in the spool in the directional valve. This means that the usual flow rate, which is determined by the size of the spool, can be reduced or limited to any desired level by means of a small hand wheel.

Optionally, this function can be combined with an individual pressure compensator for independent parallel operation, and also with a flow cut-off function. The valves must be mounted on flange face U of the directional valve.

This section can not be combined with the manual override design on the LP8S / LM8S valves.

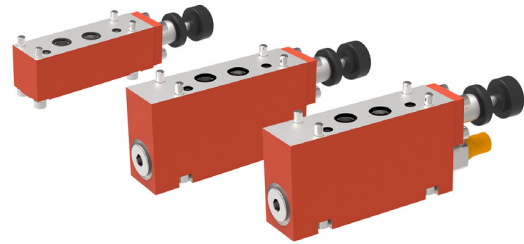

#### 7.2.2 Technical data

General characteristics	Unit	Description, value
Operating pressure	bar	max. 300
Pressure for flow cut-off	bar	adjustable, 50 ... 300
Nominal flow rate	l/min	max. 63

#### 7.2.3 Performance graphs

##### 7.2.3.1 Flow rate calibration LU8SSDR

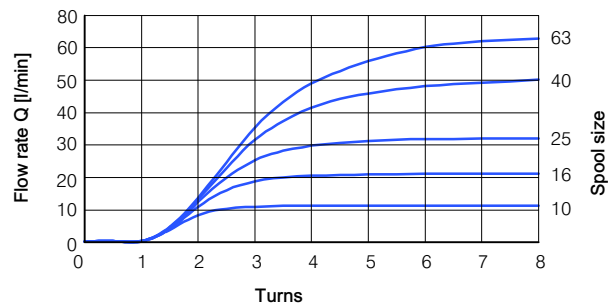

##### 7.2.3.2 Flow rate calibration LU8SSKR

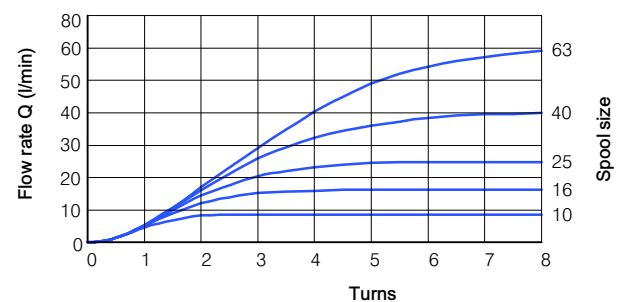

##### 7.2.3.3 Flow cut-off function in conjunction with an LU8SSKS bottom-mounting section

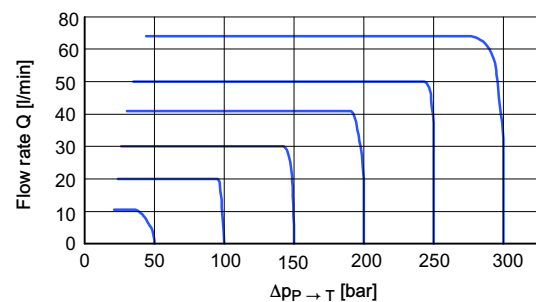

7.2.4 Overview of sections

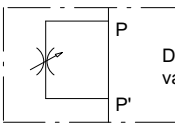
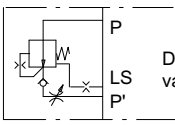
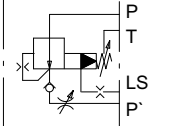
Symbol	Description	Part number
 <p>Directional valve</p>	<b>LU8SSDR-0*00/Q=</b> <ul style="list-style-type: none"> <li>with flow limiter</li> </ul>	see order details chapter 1.1
 <p>Directional valve</p>	<b>LU8SSKR-0*00</b> <ul style="list-style-type: none"> <li>with flow limiter</li> <li>with 2-way compensator</li> </ul>	100017752
 <p>Directional valve</p>	<b>LU8SSKS-0*00/P=</b> <ul style="list-style-type: none"> <li>with flow limiter</li> <li>with 2-way compensator</li> <li>with flow cut-off</li> </ul>	see order details chapter 1.1

7.2.5 Dimensions

7.2.5.1 LU8SSDR

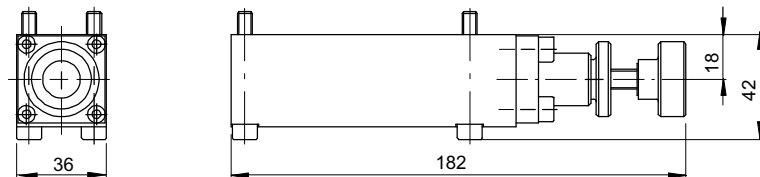

7.2.5.2 LU8SSKR / SKS

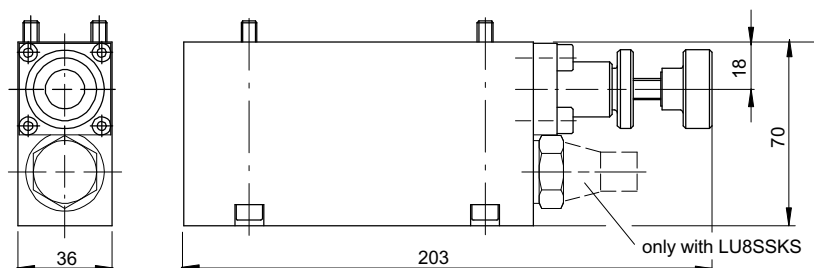

## 7.3 Pressure reducing compensators

### 7.3.1 Description

These pressure reducing compensators, which bolt-on to the bottom of the directional valve, can be switched between the individual compensator and 3-way pressure reducing functions. By energising solenoid Y, the valve is switched into individual-compensator mode. In pressure-reducing mode, preselection of the appropriate actuator line allows a preset pressure to act at port A or B. The pressure setting can be altered by hand or by electro-proportional solenoid (solenoid X).

The valves must be mounted on flange face U of the directional valve.

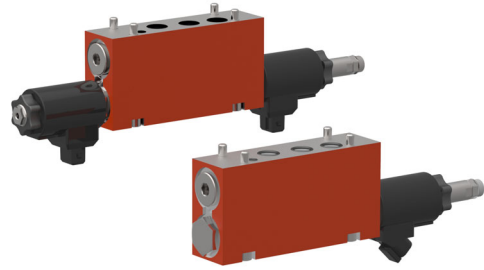

### 7.3.2 Technical data

General characteristics	Unit	Description, value		
		Pressure range 1-4 electro-proportional	Pressure range 6-8 manual setting	
Pressure range	1-8	bar	63, 100, 160, 230	100, 160, 250
Operating pressure	bar	max. 250		
Minimum pressure always	bar	15 above tank pressure		
Nominal flow rate	l/min	max. 25		
Solenoid voltage	V DC	12 or 24		
Connector socket		DT04-2P-EP04, AMP Junior Timer		
Power consumption	Watt	solenoid X solenoid Y	max. 19	27
Duty cycle	%	solenoid X solenoid Y	100 at $I_{max}$	1,4 A ( $U_N$ 12 V) / 0,7 A ( $U_N$ 24 V)
Enclosure protection		AMP: IP65	DT: IP67 (DIN EN 60529)	

### 7.3.3 Performance graphs

#### 7.3.3.1 Pressure control characteristic with proportional control of solenoid X

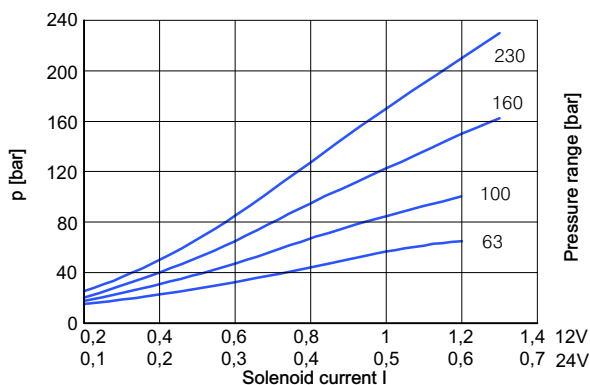

#### 7.3.3.2 Typical pressure profile 3-way pressure control electroproportional

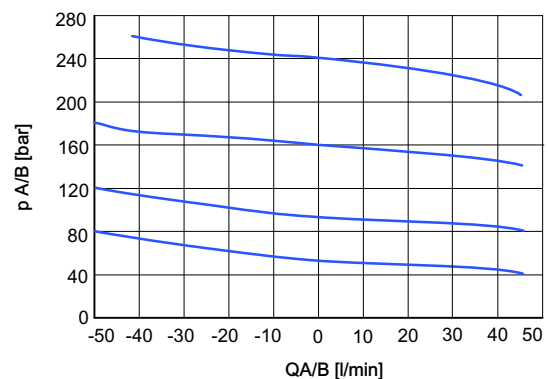

7.3.4 Overview of sections

7.3.4.1 LU8SSDK-... - Pressure reducing compensator switchable to 2-way compensator

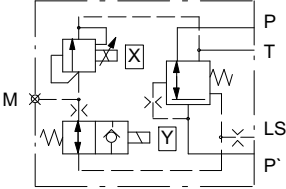
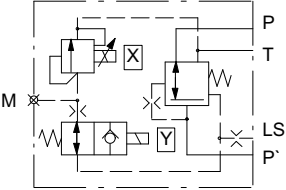
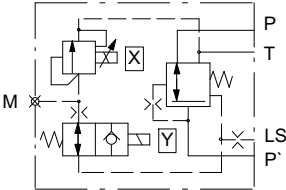
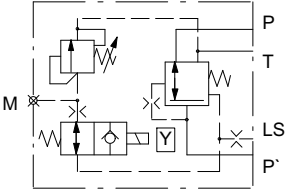
Symbol	Description	Part number
	<b>LU8SSDK2-1J12*00</b> <ul style="list-style-type: none"> <li>• switchable to 2-way compensator</li> <li>• pressure setting : electro-proportional p= 100 bar</li> <li>• connector socket: AMP Junior Timer</li> <li>• nominal voltage 12 V DC</li> </ul>	<b>100039398</b>
	<b>LU8SSDK3-1J24*00</b> <ul style="list-style-type: none"> <li>• switchable to 2-way compensator</li> <li>• pressure setting : electro-proportional p= 160 bar</li> <li>• connector socket: AMP Junior Timer</li> <li>• nominal voltage 24 V DC</li> </ul>	defined by order
	<b>LU8SSDK4-1T12*00</b> <ul style="list-style-type: none"> <li>• switchable to 2-way compensator</li> <li>• pressure setting : electro-proportional p= 230 bar</li> <li>• connector socket: DT04-2P-EP04</li> <li>• nominal voltage 12 V DC</li> </ul>	defined by order
	<b>LU8SSDK6-1T12*00/P=</b> <ul style="list-style-type: none"> <li>• switchable to 2-way compensator</li> <li>• pressure setting : manual p= 100 bar</li> <li>• connector socket: DT04-2P-EP04</li> <li>• nominal voltage 24 V DC</li> </ul>	see order details chapter 1.1

7.3.4.2 LU8SSDO-.... - Pressure reducing compensator not switchable

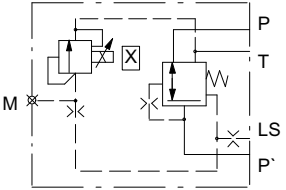
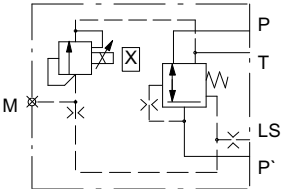
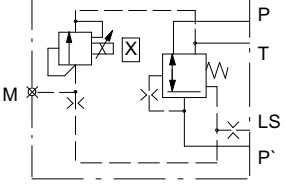
Symbol	Description	Part number
	<b>LU8SSDO1-1T24*00</b> <ul style="list-style-type: none"> <li>• not switchable to 2-way compensator</li> <li>• pressure setting : electro-proportional p= 63 bar</li> <li>• connector socket: DT04-2P-EP04</li> <li>• nominal voltage 24 V DC</li> </ul>	<b>100034455</b>
	<b>LU8SSDO2-2T12*00</b> <ul style="list-style-type: none"> <li>• not switchable to 2-way compensator</li> <li>• pressure setting : electro-proportional p= 100 bar</li> <li>• connector socket: DT04-2P-EP04</li> <li>• nominal voltage 12 V DC</li> </ul>	defined by order
	<b>LU8SSDO3-1T24*00</b> <ul style="list-style-type: none"> <li>• not switchable to 2-way compensator</li> <li>• pressure setting : electro-proportional p= 160 bar</li> <li>• connector socket: DT04-2P-EP04</li> <li>• nominal voltage 24 V DC</li> </ul>	defined by order

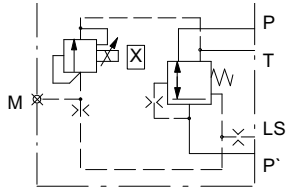
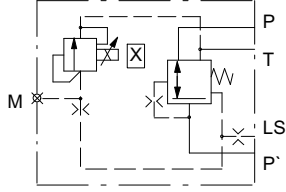
	<b>LU8SSDO4-1J12*00</b>	<b>100036098</b>
	<ul style="list-style-type: none"> <li>• switchable to 2-way compensator</li> <li>• pressure setting : electro-proportional p= 230 bar</li> <li>• connector socket: AMP Junior Timer</li> <li>• nominal voltage 12 V DC</li> </ul>	
	<b>LU8SSDO4-1T12*00</b>	<b>100035166</b>
	<ul style="list-style-type: none"> <li>• not switchable to 2-way compensator</li> <li>• pressure setting : electro-proportional p= 230 bar</li> <li>• connector socket: Deutsch plug DT04-2P-EP04</li> <li>• nominal voltage 12 V DC</li> </ul>	

Others on enquiry.

### 7.3.5 Connector socket

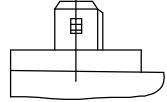
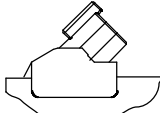
<b>AMP Junior Timer</b> <b>J</b>	<b>Deutsch plug DT04-2P-EP04</b> <b>T</b>
	

### 7.3.6 Dimensions

#### 7.3.6.1 Pressure range 1 - 4

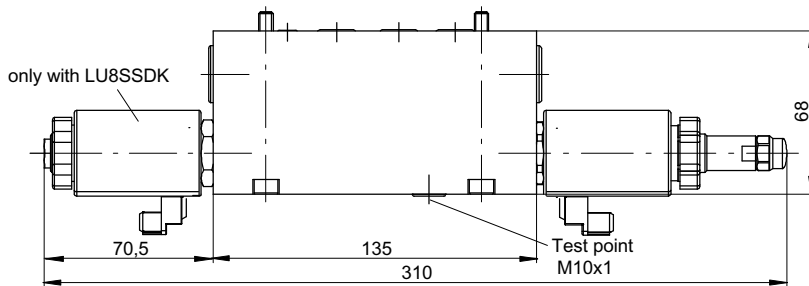

#### 7.3.6.2 Pressure range 6 - 8

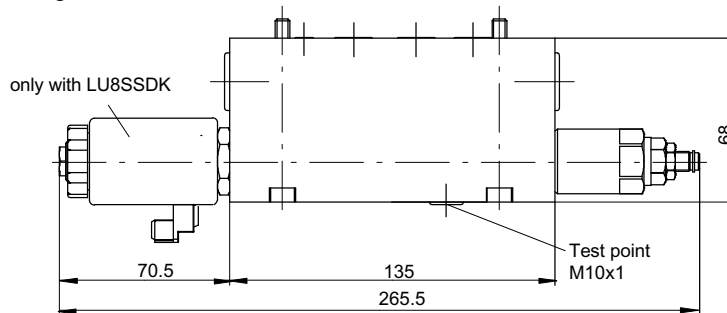

## 8 End sections

### 8.1 End sections with no control function

#### 8.1.1 Description

End sections with no control function are intended for the end of a valve block when no other control functions are needed. The LS signal is unloaded to tank.

The ports needed for the particular model are provided, as are tapped holes for securing the valve block.

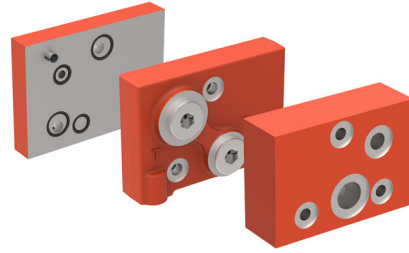

#### 8.1.2 Overview of sections

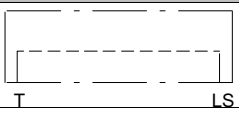
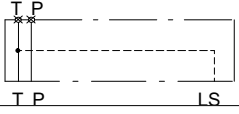
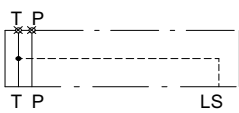
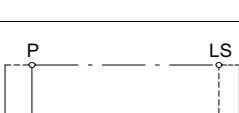
Symbol	Description	Part number
	<b>LU8SPUB-1*00</b> • end section without port • LS to T	<b>100040275</b>
	<b>LU8SPUT-1M22*00</b> • tank port T and pressure port P = M22 x 1,5 • LS to T	<b>100038056</b>
	<b>LU8SPUT-1M26*00</b> • tank port T = M26 x 1,5 • pressure port P = M22 x 1,5 • LS to T	<b>100039952</b>
	<b>LU8SPWS-0M22*00</b> • pressure port P = M22 x 1,5 • LS port = M14 x 1,5 • LS carry-over (if unloading, remember the LS signal)	<b>100041051</b>

#### 8.1.3 Dimensions

##### 8.1.3.1 LU8SPUB

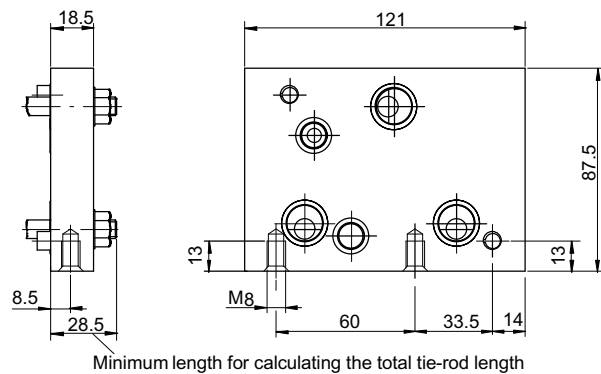

##### 8.1.3.2 LU8SPUT

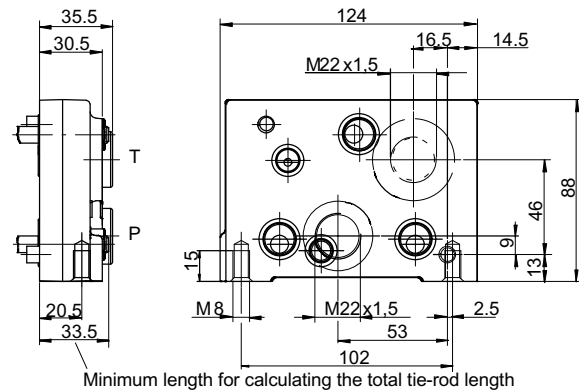

##### 8.1.3.3 LU8SPWS

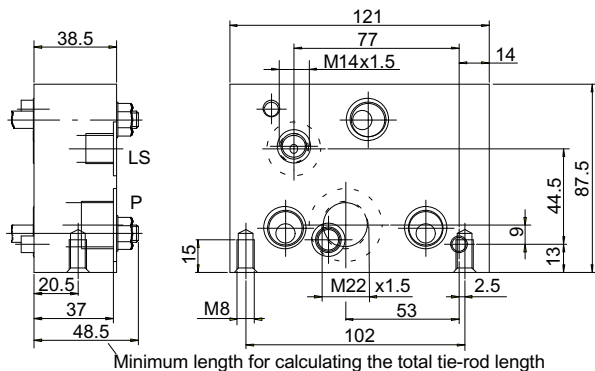

### 8.2 Priority section

#### 8.2.1 Description

Intended for the end of a valve block, the LU8SPUO/PUP... priority section includes a priority function for the external control system supplied by the ports P<sub>P</sub> and LS, and the surplus flow side.

In the under-supply range (pump flow < total flow needed by the valve block), the surplus flow side will receive only a portion of what it needs, or possibly (pump flow < priority flow setting) no flow whatsoever.

The priority side can also be equipped with a pressure relief valve that ensures a priority flow cut-off when the pressure setting is reached. For oscillation-prone applications, a damping element (e.g. An accumulator) can be connected to a port specially provided for this purpose. Preferred applications are in LS systems.

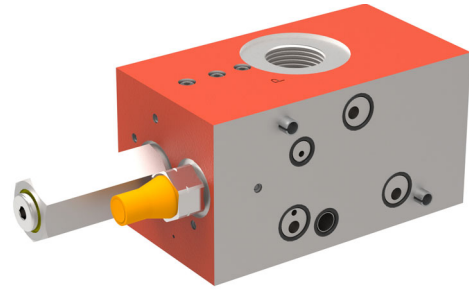

#### 8.2.2 Technical data

General characteristics	Unit	Description, value
Inlet pressure	bar	max. 300
Nominal flow rate	l/min	max. 120
Control $\Delta p$ for the compensator	bar	12
Pressure for flow cut-off on the priority side	bar	adjustable

#### 8.2.3 Performance graphs

##### 8.2.3.1 Pressure drop characteristic

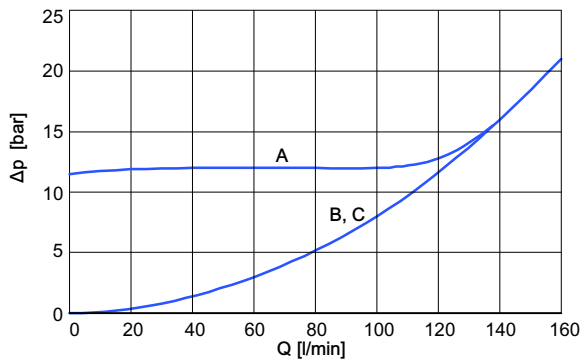

A	P <sub>Pump port</sub> to P <sub>Surp</sub> (Q <sub>Priority</sub> = zero) at P <sub>Surp</sub> = P <sub>LS</sub>
B	P <sub>Pump port</sub> to P <sub>Surp</sub> at $\Delta p$ P <sub>Surp</sub> to LS > 20 bar
C	P <sub>Pump port</sub> to P <sub>priority</sub> (control spool in neutral position)

##### 8.2.3.2 Flow cut-off on the priority side

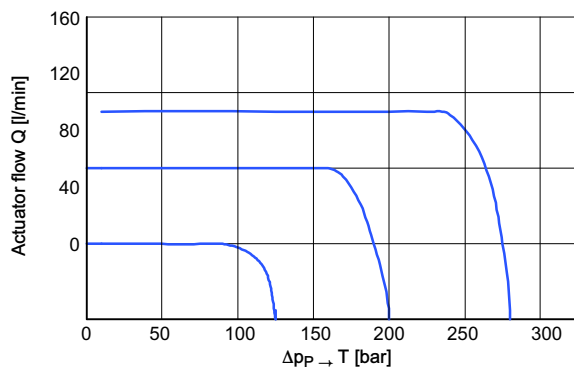

8.2.4 Overview of sections

Symbol	Description	Part number
	<p>LU8SPUP-0B10*01/P=</p> <ul style="list-style-type: none"> <li>• flow cut-up</li> <li>• port threads G1" / BSP 1"</li> </ul>	see order details chapter 1.1

8.2.5 Dimensions

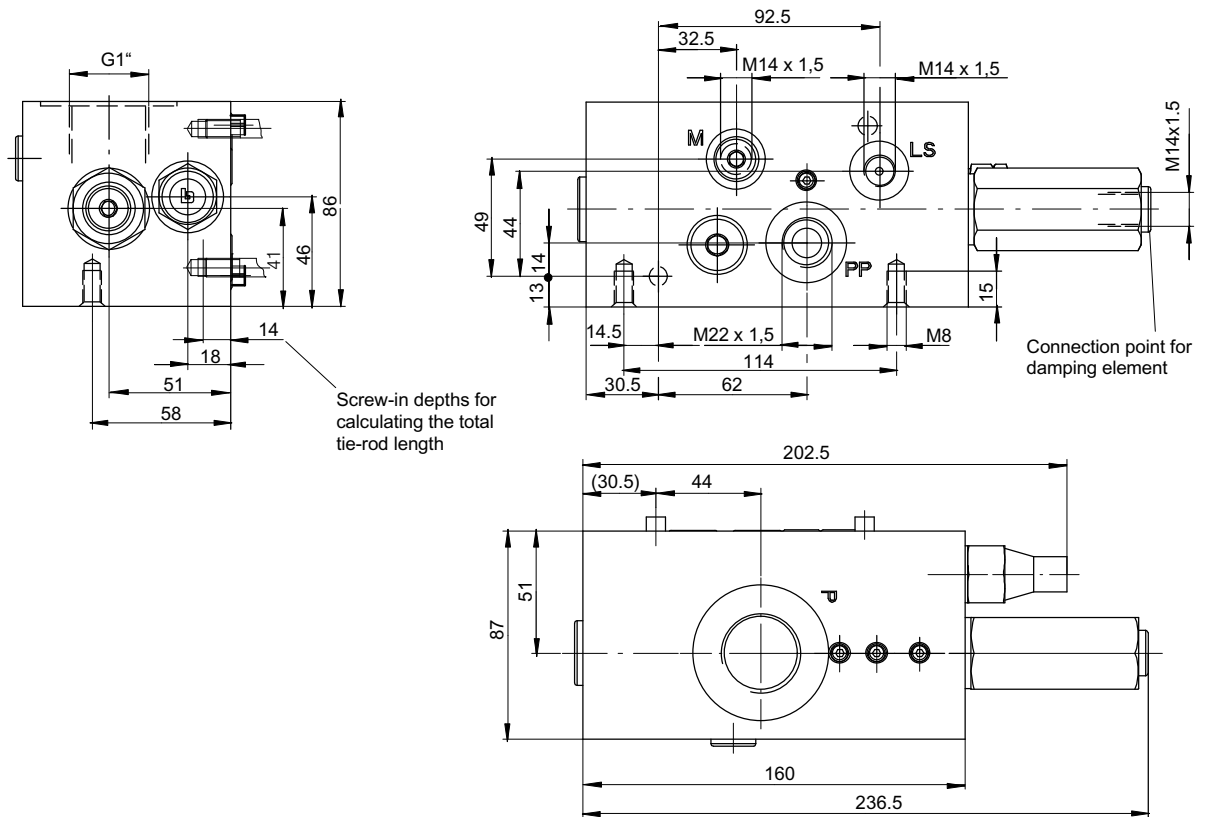

### 8.3 With direct-acting pressure relief

#### 8.3.1 Description

For terminating the block with integral direct-acting pressure relief (e.g. secondary pressure relief in LS systems). The application limits must not be exceeded. A test point for P, and tapped holes for securing the valve block are provided.

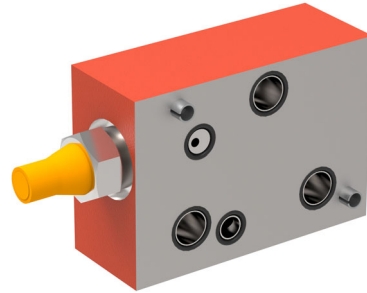

#### 8.3.2 Technical data

General characteristics	Unit	Description, value
Inlet pressure	bar	max. 300
Nominal flow rate	l/min	see characteristic curve
Pressure range	bar	35 - 95 95 - 210 210 - 300

#### 8.3.3 Characteristic curve

##### 8.3.3.1 Pressure relief characteristic

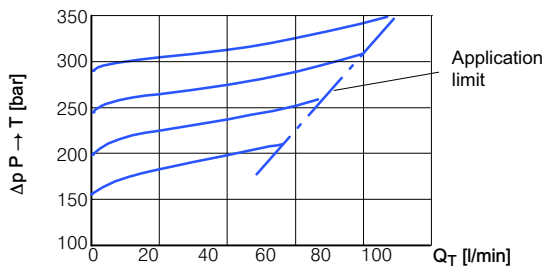

#### 8.3.4 Overview of sections

Symbol	Description	Part number
	<b>LU8SPUD3-0M14*00/P=</b> <ul style="list-style-type: none"> <li>• end section</li> <li>• pressure range 210 ... 300 bar (others on enquiry)</li> <li>• port thread to DIN 3852 - M14 x 1,5 (test point)</li> </ul> ⇒ specify the pressure relief setting in bar	see order details chapter 1.1

#### 8.3.5 Dimensions

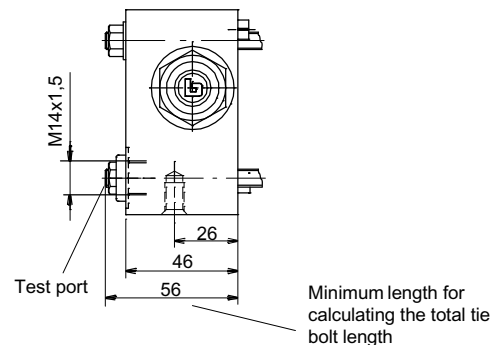
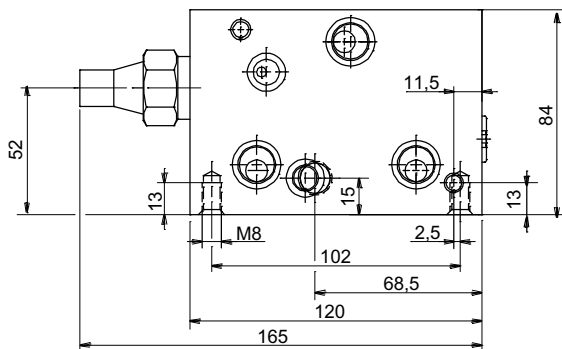

## 8.4 With pressure reducing function e.g. for hydraulic joystick

### 8.4.1 Description

This end section includes a 3-way pressure reducing valve and the ports PX and TX. The reduced pressure available at port PX can be varied by the adjusting screw to any required level from 10 to 100 bar. A typical application is providing the supply for hydraulic joysticks. No tank unload facility at the upper tie bolt gallery. The upper tank gallery is not connected to the tank port.

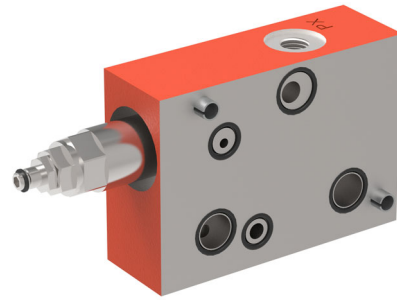

### 8.4.2 Technical data

General characteristics	Unit	Description, value
Operating pressure	bar	max. 250
Flow rate at port PX	l/min	max. 15
Reduced pressure at PX preset	bar	50
Reduced pressure at PX adjustable	bar	max. 100

### 8.4.3 Overview of sections

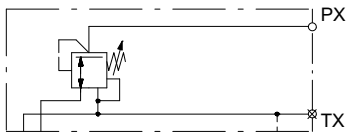
Symbol	Description	Part number
	<b>LU8SPUH-0B14*00/PX=</b> <ul style="list-style-type: none"> <li>• end section</li> <li>• port threads BSP<math>\frac{1}{4}</math>" / G<math>\frac{1}{4}</math>"</li> </ul>	see order details chapter 1.1

### 8.4.4 Dimensions

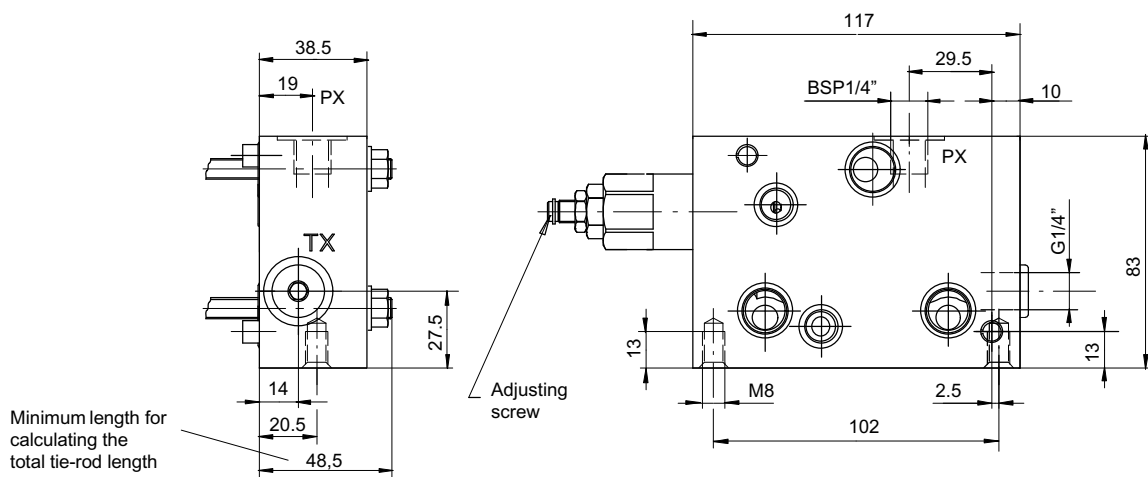

### 8.5 Load control valve with float position

#### 8.5.1 Description

For terminating the block, this has an integral load-holding valve with anti-shock function for port A. The two seat valves in A and B create the float position. When the directional valve is in the neutral position, actuator line A is shut-off with zero leakage and protected from unacceptably-high pressure peaks by an anti-shock function.

The mating directional valve is the last directional section in the block and must be a special version e.g. /02 (LC8S) or /24 (LP8S, LH8S) with spool type 4E. A typical application is the arm function in wheel loaders and front loaders.

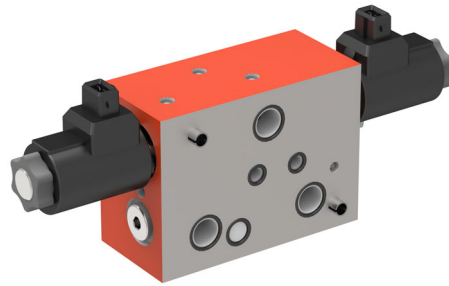

#### 8.5.2 Technical data

General characteristics	Unit	Description, value
Inlet pressure	bar	max. 210
Actuator pressure	bar	max. 250
Port threads to DIN 3852		M18 x 1,5
Pilot ratio S15 S30		1,5 : 1 3 : 1
Anti-shock valve adjustable	bar	100 ... 250
Pressure drop across load-control function	bar	30 at 63 l/min
Nominal voltage	V DC	12 or 24
Power consumption	Watt	50
Duty cycle	%	100
Connector socket		DIN 43650
Enclosure protection		AMP Junior Timer: IP65 Deutsch plug DT04-2P-EP04: IP67 (DIN EN 60529)

#### 8.5.3 Overview of sections

Symbol	Description	Part number
	<b>LU8SPUE-S15***-0M18J12*00/PA=</b>	see order details chapter 1.1
	<ul style="list-style-type: none"> <li>• end section</li> <li>• actuator port A: load control function pilot ratio 1,5 : 1</li> <li>• nominal voltage 12 V DC</li> <li>• connector socket: AMP Junior Timer</li> </ul> ⇒ specify the pressure relief setting in bar	
	<b>LU8SPUE-S30***-0M18T12*00/ PA=</b>	see order details chapter 1.1
	<ul style="list-style-type: none"> <li>• end section</li> <li>• actuator port A: load control function pilot ratio 3 : 1</li> <li>• nominal voltage 12 V DC</li> <li>• connector socket: DIN 43650</li> </ul> ⇒ specify the pressure relief setting in bar	

	<b>LU8SPUE-S30***-0M18T24*00/P=</b>	see order details chapter 1.1
<ul style="list-style-type: none"> <li>• end section</li> <li>• actuator port A: load control function pilot ratio 3 : 1</li> <li>• nominal voltage 24 V DC</li> <li>• connector socket: DIN 43650</li> </ul> <p>⇒ specify the pressure relief setting in bar</p>		

## 8.5.4 Connector socket

AMP Junior Timer J	Deutsch plug DT04-2P-EP04 T

## 8.5.5 Dimension

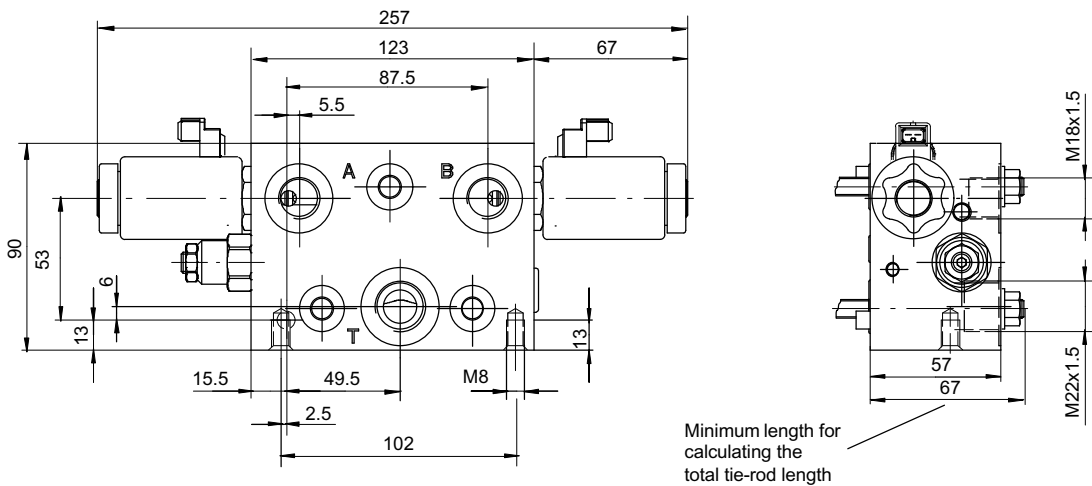

## 8.6 Safety valve for electro-hydraulic steering systems

### 8.6.1 Description

Block end section as safety valve for electro-hydraulic steering systems. When the electro-hydraulic steering is activated by energising the attached proportional valve (e.g. LC8S), the two 3/2 directional valves are also energised at the same time. As a result, the steering Orbitrol is disconnected. In automatic mode, if manual (i.e. emergency) steering corrections have to be made without first switching off automatic mode, a pressure develops in R or L, depending on the direction the Orbitrol is turned.

This pressure passes through the shuttle valve to a pressure switch. The signal from the pressure switch cancels the automatic function and all solenoids are de-energised. Thus, the Orbitrol is directly connected to the steering cylinder and the normal manual steering function is active.

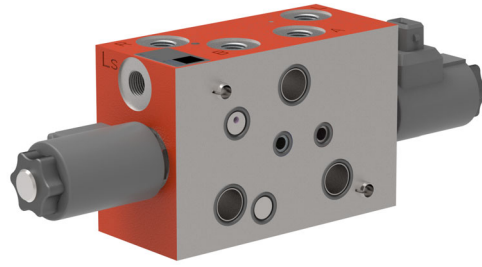

### 8.6.2 Technical data

General characteristics	Unit	Description, value
Inlet pressure	bar	max. 210
Nominal flow rate	l/min	25
Nominal voltage	V DC	12
Power consumption	Watt	27
Duty cycle	%	100
Connector socket		DIN 43650
Enclosure protection		AMP: IP65 DT: IP67 (DIN EN 60529)

### 8.6.3 Overview of sections

Symbol	Description	Part number
	<b>LU8SPUL-0B14J24*00</b> <ul style="list-style-type: none"> <li>• end section</li> <li>• connector socket: AMP Junior Timer</li> <li>• nominal voltage 24 V DC</li> </ul>	<b>100039804</b>
	<b>LU8SPUL-0B14T12*00</b> <ul style="list-style-type: none"> <li>• end section</li> <li>• connector socket: DT04-2P-EP04</li> <li>• nominal voltage 12 V DC</li> </ul>	<b>100033035</b>

### 8.6.4 Connector socket

AMP Junior Timer J	Deutsch plug DT04-2P-EP04 T

8.6.5 Dimensions

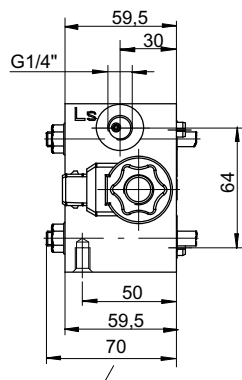

Minimum length for calculating the total tie bolt length

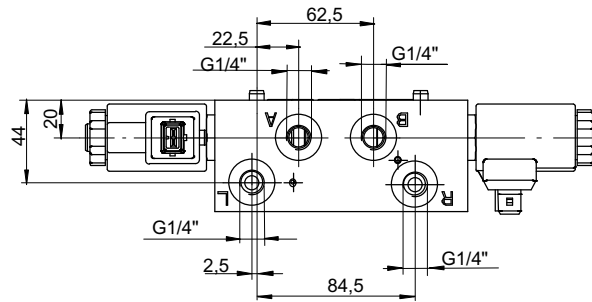
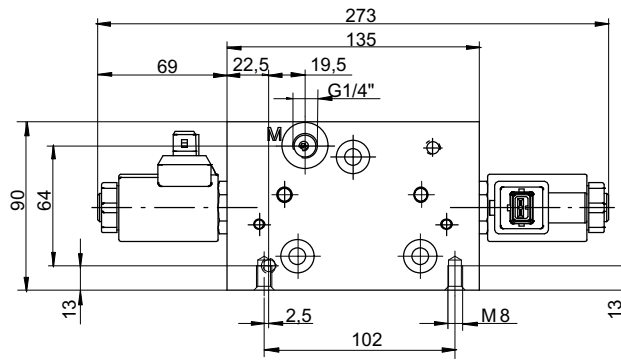

### 9 Accessories

#### 9.1 Seat valves series SVH04

##### 9.1.1 Single and multi-monoblocks for attaching to L.8S valves

###### 9.1.1.1 Symbols

SVH04M228S-...

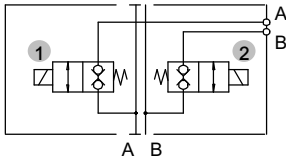
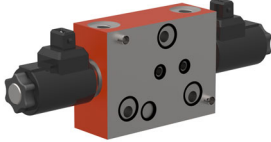

SVH04M448S-...

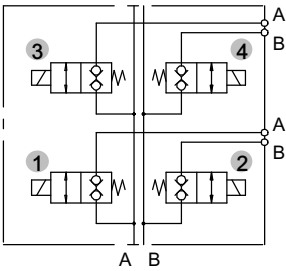
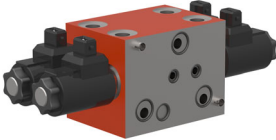

SVH04M668S-...

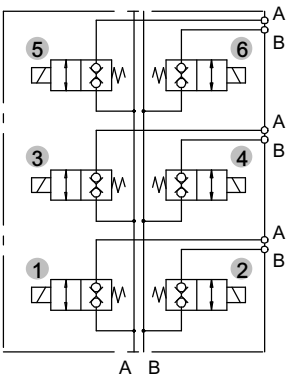
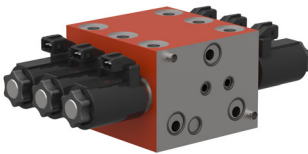

SVH04M888S-...

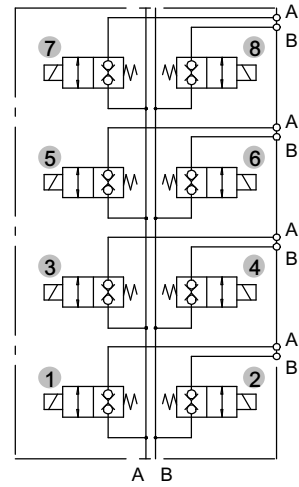
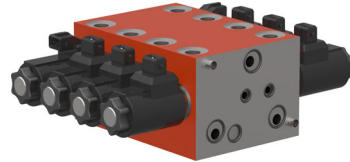

SVH04M008S-...

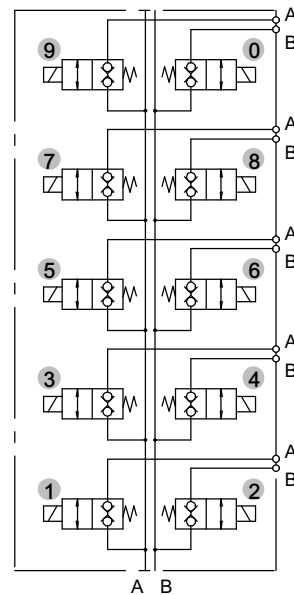
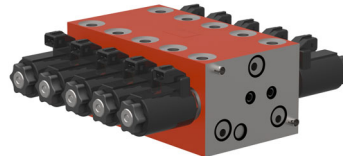

Detailed information see data sheet 100-P-00043.

## 9.2 Analogue systems

### 9.2.1 Overview of components

Description	Ordering code	Data sheet
Electrical joysticks	(see data sheet)	100-P-700071
Plug Junior Timer 2-pole	100152575	
Plug Junior Timer complete	100152579	
Deutsch DT04-2P-EP04	100608468	
Solenoid connection cable	100153209	

## 9.3 Proportional amplifier

Description	Ordering code	Data sheet
Master Module Series EBM		100-P-700071

## 9.4 Assembly kit

### 9.4.1 Description

To assemble the individual control block with assured functional reliability, 3 tie-rods and 3 resp. 6 hex. nuts are always necessary. Maximum tightening torque = 30 Nm. Tighten in 3 steps of 6, 16 and 30 Nm.

### 9.4.2 Ordering code

3 pcs. tie-rods M8 x ..... (required length in mm)  
3 or 6 pcs. (depending on block configuration)  
Seal-Lock sealing nut M8,  
Part No: 100280470

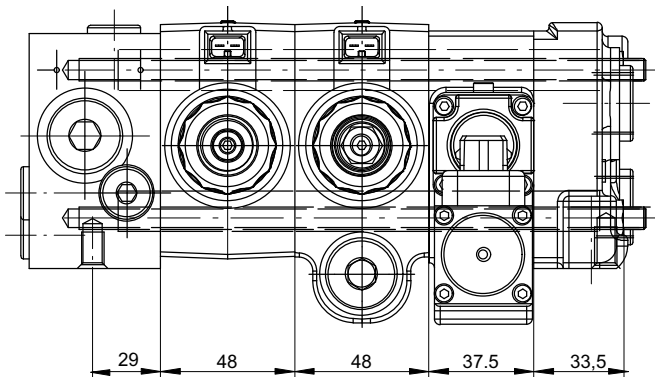

#### Calculating the tie-rod length:

Inlet section + 48 mm (LP,LM,LH =37,5 mm) x no. of directional valve sections + width of the end section

#### Example:

$$29+(48 \times 2)+37,5+33,5 = 194 \text{ mm}$$

For ordering purposes, always round up to the calculated tie-rod length to the next 10 mm.

In our example, we therefore need to order 3 pcs. Tie-rods á M8 x 200 mm.

**IMPORTANT:** Maximum 10 directional sections in 1 valve block.

## 10 Liability

In the design and operation of hydraulic systems, all aspects of the potential failure modes and all planned operational conditions and uses of the equipment must be taken into consideration.

Concerning risk assessment, please refer to the relevant Standards. The use of components that are not Original Bucher Replacement Parts and Accessories nullifies all warranty.

## 11 Note

This catalogue is intended for users with specialist knowledge. To ensure that all of the conditions necessary for the function and safety of the system are fulfilled, users must satisfy themselves as to the suitability of the units described here in. If there are any areas of doubt, please consult Bucher Hydraulics.

[info.kl@bucherhydraulics.com](mailto:info.kl@bucherhydraulics.com)

[www.bucherhydraulics.com](http://www.bucherhydraulics.com)

© 2025 by Bucher Hydraulics GmbH, D-79771 Klettgau

Alle Rechte vorbehalten.

Die angegebenen Daten dienen allein der Produktbeschreibung und sind nicht als zugesicherte Eigenschaften im rechtlichen Sinne zu verstehen. Die Angaben entbinden den Anwender nicht von eigenen Beurteilungen und Prüfungen. Auf Grund kontinuierlicher Verbesserungen der Produkte sind Änderungen der in diesem Katalog gemachten Produktspezifikationen vorbehalten.

Klassifikation: 430.300.330.