

# Stacking 2/2 Directional Valve, ISO size 5 Solenoid Controlled, Seated Pilot, Seated Spool Main Stage Series SWR22..EDA...-10

- 315 bar, 140 l/min
- With two-stage, solenoid controlled 2/2 cartridge valve, type WR22 ...-10
- 'No flow' pilot stage
- All ports rated to 315 bar
- P-line functions have a secondary pressure gauge connection M (G 1/4")
- Corrosion protection: stacking body is zinc-phosphated
- With ISO 4401 / CETOP R35H size 5, NFPA D05, DIN 24 340 A10 interface

## 1. Symbols

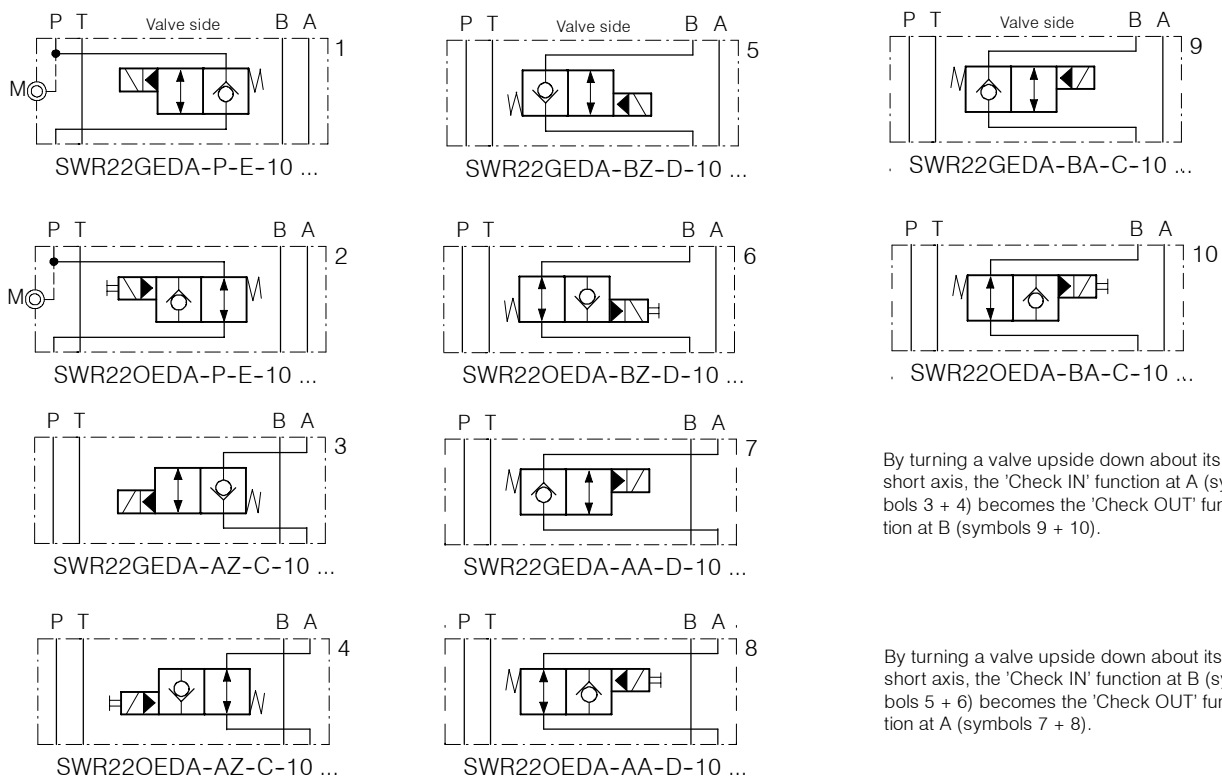

## 2. Dimensions

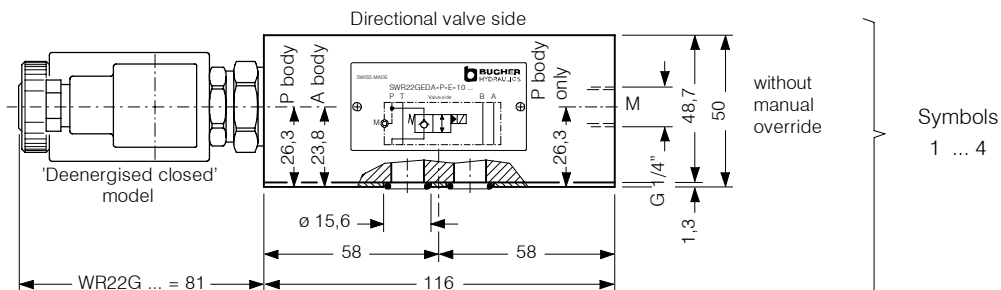

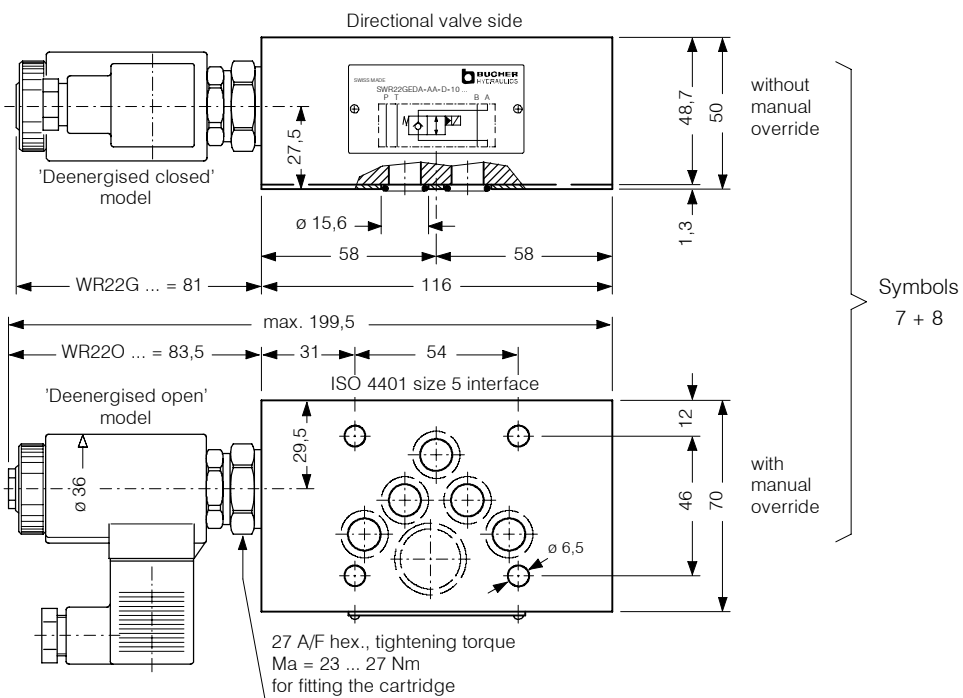
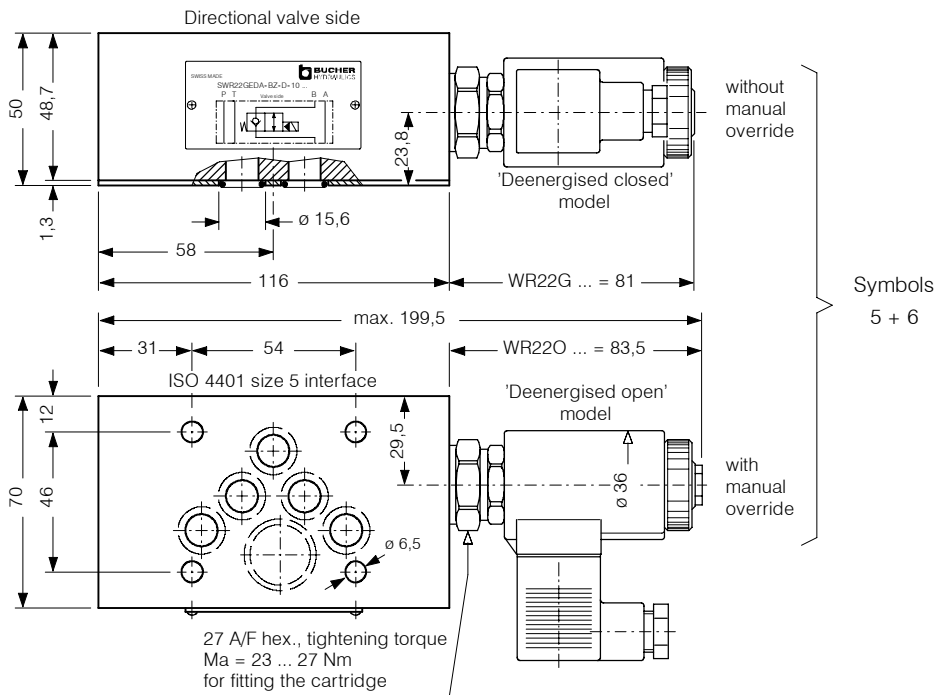
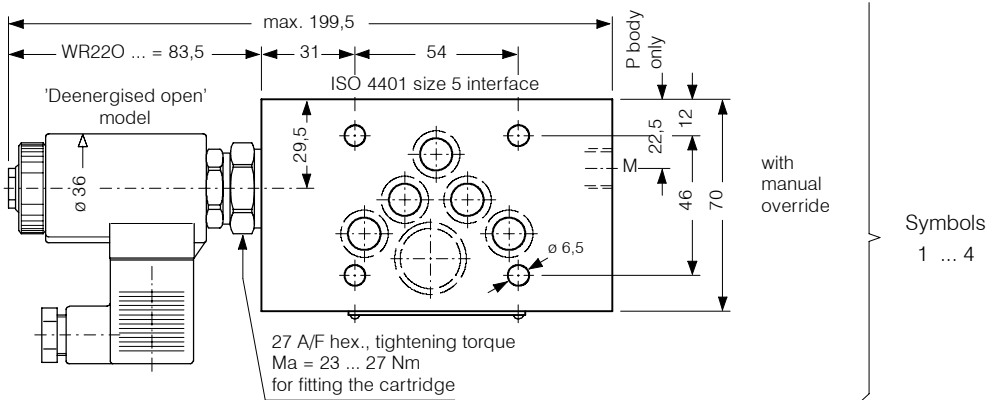

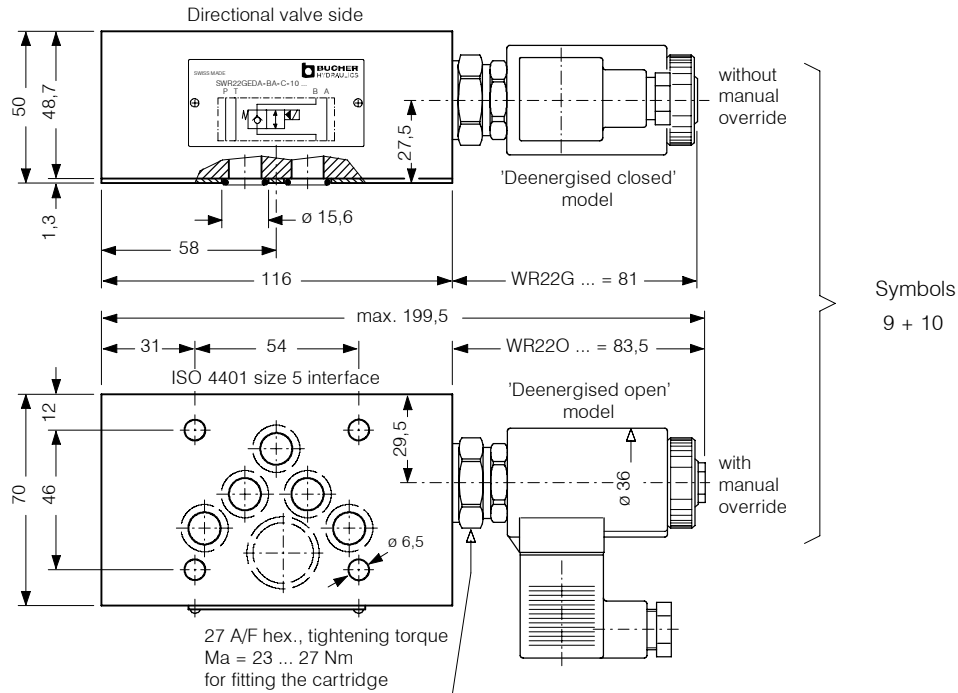

### 3. Schematic section

showing the relevant ports

Ex. SWR22GEDA-AZ-C-10 ... (Check IN function)

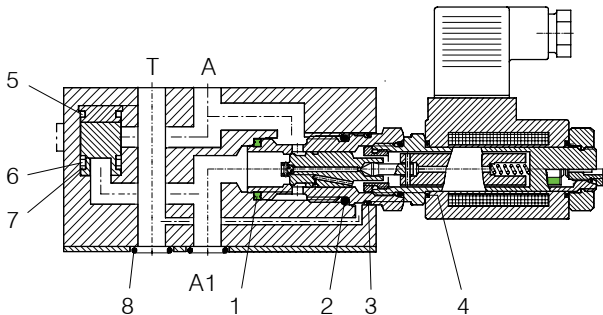

Seal kit no. DS-313, comprising \*):

Itm.	Qty.	Qty.	Description	Size
1	1*)	1	Seal ring	Ø 22,1 / 16,5 x 2,5
2	1*)	1	O-ring no. 117	Ø 20,29 x 2,62 N90
3	1*)	1	O-ring no. 020	Ø 21,95 x 1,78 N90
4	2*)	2	O-ring	Ø 16,00 x 2,00 Viton
5	1*)	-	O-ring no. 018	Ø 18,77 x 1,78 N90
6	1*)	-	O-ring no. 016	Ø 15,60 x 1,78 N90
7	2*)	-	Backup ring	Ø 20,0 / 16,9 x 1,4
8	5*)	5	O-ring no. 014	Ø 12,43 x 1,78 N90

Ex. SWR22GEDA-AA-D-10 ... (Check OUT function)

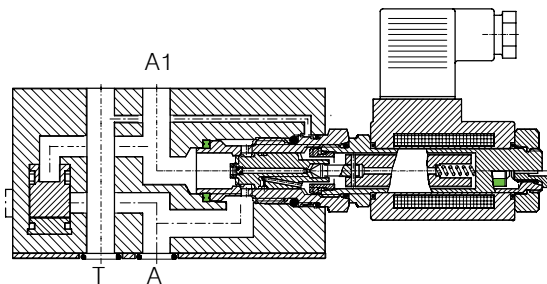

SWRA22..EDA-P-E-10 ...  
SWRA22..EDA-AA/BZ-D-10 ... &  
SWRA22..EDA-AZ/BA-C-10 ...

### 4. Installation and servicing

All installation and servicing must be carried out with care, and by qualified personnel only. At installation, make sure that the valve interface aligns with the interface of the mating surface and

do not confuse the directional valve ('top') and manifold ('bottom') faces of the valve. When changing seals, the new seals should be thoroughly oiled or

greased before they are fitted. When fitting the cartridge, ensure that the seals are oiled or greased and use the specified tightening torque.

## 5. Ordering code

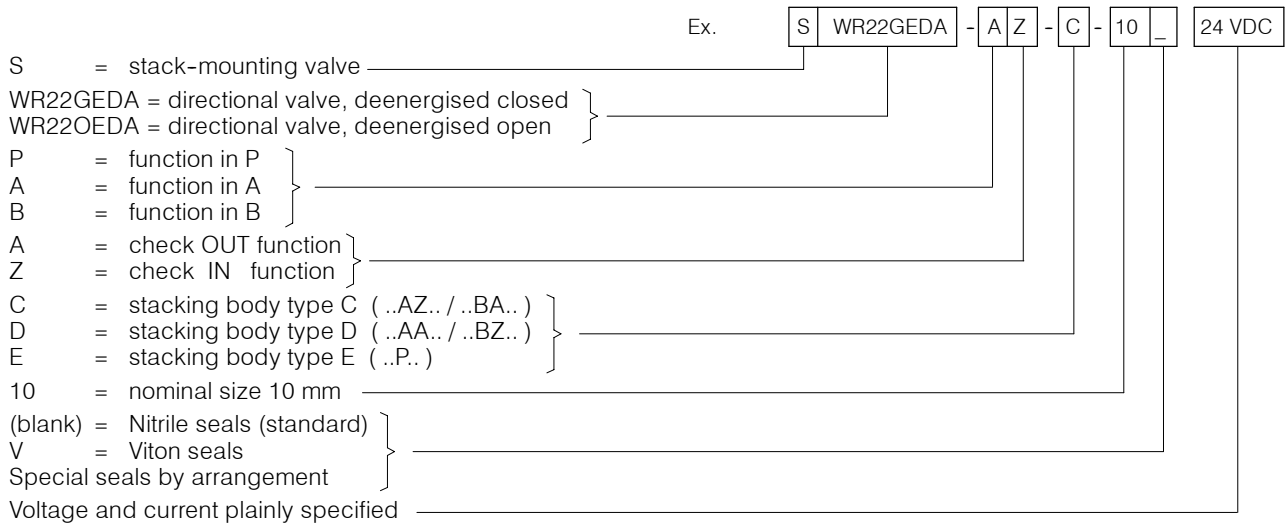

## 6. Related data sheets

Old no.	New no.	
i - 00	400-P-010101-E	Table of interface equivalents
i - 41	400-P-050101-E	DIN 24 340 size A10 interface
W - 6.155	400-P-131110-E	2/2 Solenoid Cartridge Valve WR22 ...-10
G - 45	400-P-810901-E	Seal Plate DB-10

[info.ch@bucherhydraulics.com](mailto:info.ch@bucherhydraulics.com)

[www.bucherhydraulics.com](http://www.bucherhydraulics.com)

© 2015 by Bucher Hydraulics AG Frutigen, CH-3714 Frutigen

All rights reserved.

Data is provided for the purpose of product description only, and must not be construed as warranted characteristics in the legal sense. The information does not relieve users from the duty of conducting their own evaluations and tests. Because the products are subject to continual improvement, we reserve the right to amend the product specifications contained in this catalogue.