

Lock valve

Spring-loaded non-return valve

$Q_{\max} = 15 \text{ l/min}$, $p_{\max} = 350 \text{ bar}$
plate type,
Type series: RVC-04-...

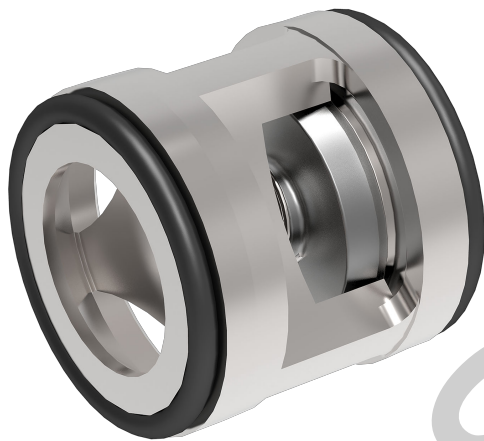

- Slip-in cartridge valve
- Can be used as a screw-in valve in conjunction with an ESH threaded mounting sleeve
- Exceptionally high Q_{\max} with extremely low Δp
- No-flow direction can be reversed
- Virtually leak-proof in closed condition
- Optional metered flow in the no-flow direction
- Particularly suitable for use as a make-up check valve

Description

The RVC series plate-type check valve is characterized by very high pressure load capacity and extremely low Δp . The no-flow direction can be reversed by inverting the valve in its cavity. The slip-in cartridge valve RVC can be used in conjunction with an ESH threaded mounting sleeve like a screw-in valve. Due to its fast response, it can be used as a make-up check valve. Orifices in the valve plate allow simple

"metered check" functions. The spring-loaded poppet-type check valve in plate design is very robust, extremely leak-proof and insensitive to contamination. Valve seat, poppet and body are hardened. The properties of the sealing faces have been enhanced by precision mechanical processing. The valve is available in nominal sizes 04, 06, 08, 10, 16 and 25.

Symbol

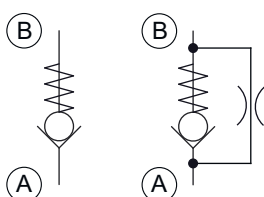

Technical data

General characteristics	Description, value, unit
Product status	Phase-Out
Alternative product	RKVC-04-... (170-P-051201)
Function group	Lock valve
Function	Spring-loaded non-return valve
Design	Slip-in cartridge valve
Characteristic	plate type
Construction size	nominal size 04
Thread size	G 1/8"
Mounting attitude	unrestricted
Weight	0.003 kg

Hydraulic characteristics	Description, value, unit
Maximum operating pressure	350 bar
Maximum flow rate	15 l/min
Nominal flow rate	8 l/min
Flow direction	see symbol
Hydraulic fluid	HL and HLP mineral oil according to DIN 51 524; other fluids on request!
Minimum fluid temperature	- 30 °C
Maximum fluid temperature	+ 80 °C
Viscosity range	10 ... 500 mm ² /s (cSt)
Minimum fluid cleanliness (cleanliness class according to ISO 4406:1999)	class 20/18/15
Opening pressure	0.2..0.3 / 1.0 / 2.0 bar



NOTE!

For other values please contact Bucher Hydraulics.

Performance graphs

measured with oil viscosity 33.0 mm²/s (cSt)

$\Delta p = f(Q)$ Pressure drop-flow rate characteristic

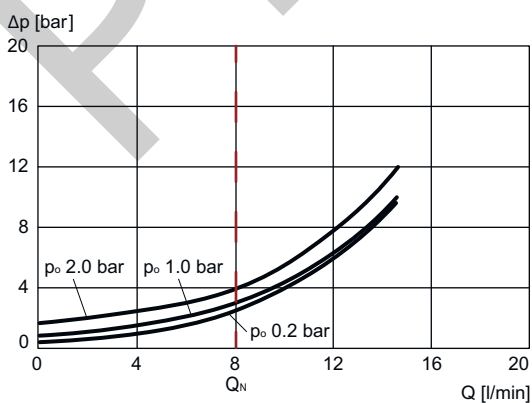

Dimensions and sectional view

RVC-04

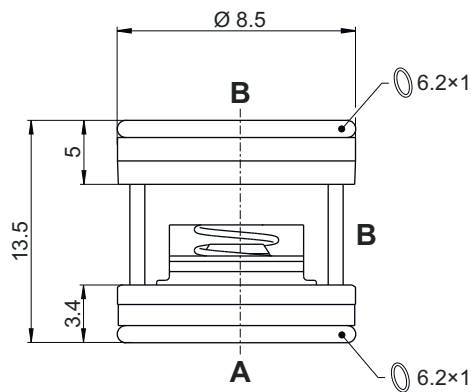

CEG-01

CEG-02

CEG-03

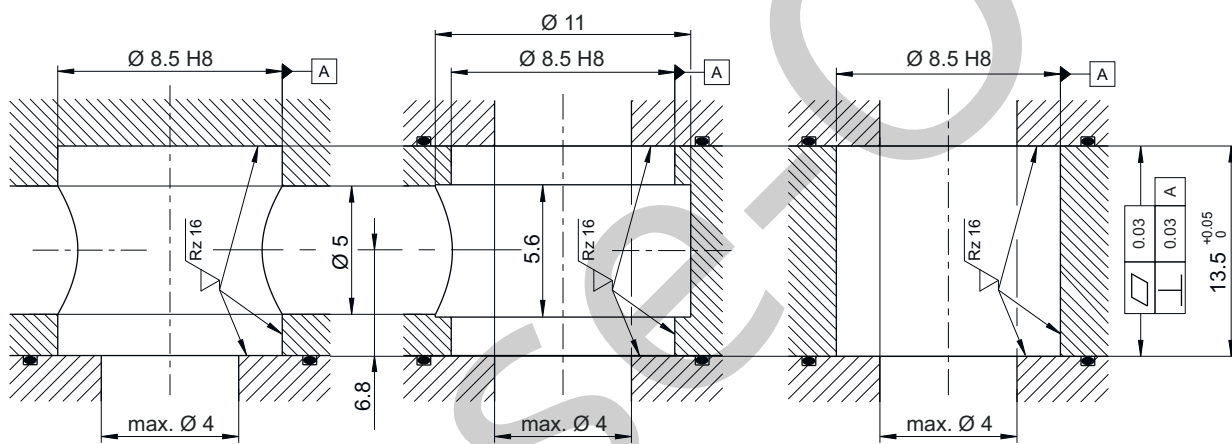

ESH-06

CEG-04

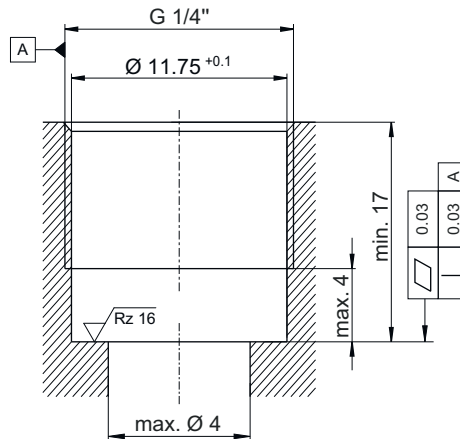
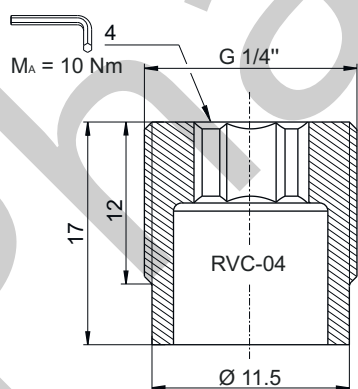

Installation information



NOTE!

The tightening torque must be observed, when installing with a threaded mounting sleeve ESH. The value can be found in the chapter dimensions and sectional view.

Orifices or nozzles are to be placed after the check valve. If this is not possible, a right-angled bore must be designated between the check valve and the nozzle. (see data sheet 170-P-059000).

Recommendation: before installing the valve, fit the O-ring in the cavity.



ATTENTION!

It must be ensured that the valve is firmly seated on the sealing surface during installation and does not protrude beyond the installation space or exceed the tolerance H.

Application Notes



NOTE!

The maximum operating pressure must not be exceeded even when pressure peaks occur. In applications such as accumulator circuits, where sudden pressure can be applied to the valve in the free-flow direction, ensure that the specified flow ratings are not exceeded. Buyers bear the sole responsibility for ensuring that the valve is suitable for their applications and must be substantiated by trials or testing, if necessary.



ATTENTION!

The valves are only suitable for pressure relief in the opening direction to a limited extent. (if necessary, please consult Bucher Hydraulics).

Ordering code

Ex. RVC - 04 - 03 - D10 - -

RVC = check valve, plate design, slip-in cartridge valve

04 = nominal size 04, $Q_{Nominal}$ 8 l/min

03 = opening pressure 0.2 up to 0.3 bar

1 = opening pressure 1.0 bar

2 = opening pressure 2.0 bar

(blank) = no orifice bore

D04 = orifice bore with diameter 0.4 mm

D05 = orifice bore with diameter 0.5 mm

D06 = orifice bore with diameter 0.6 mm

D08 = orifice bore with diameter 0.8 mm

D10 = orifice bore with diameter 1.0 mm

D12 = orifice bore with diameter 1.2 mm

D15 = orifice bore with diameter 1.5 mm

(blank) = NBR (nitril-butadien-rubber / Buna) seals (standard)

V = FKM (fluorocarbon rubber / Viton) seals

Related data sheets

Reference	Description
170-P-059000	Using nozzles or orifices before a Check Valve
170-P-080000	Cavity REG-01-04

Phase-Out

info.de@bucherhydraulics.com

www.bucherhydraulics.com

© 2025 by Bucher Hydraulics Dachau GmbH, 85221 Dachau, Germany

All rights reserved.

Data is provided for the purpose of product description only, and must not be construed as warranted characteristics in the legal sense. The information does not relieve users from the duty of conducting their own evaluations and tests. Because the products are subject to continual improvement, we reserve the right to amend the product specifications contained in this catalogue.